

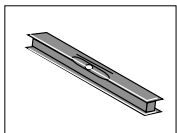

Assembly Instructions
Instructions de montage
Montageanleitung

Balance 8'x12' - Hybrid Glazing

366x242.5x231cm / 144"x95½"x91"

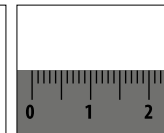
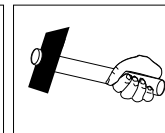
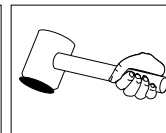
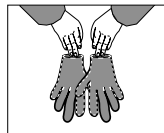
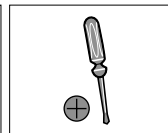
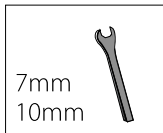
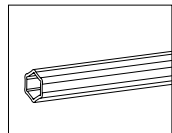
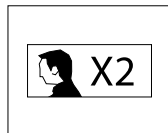
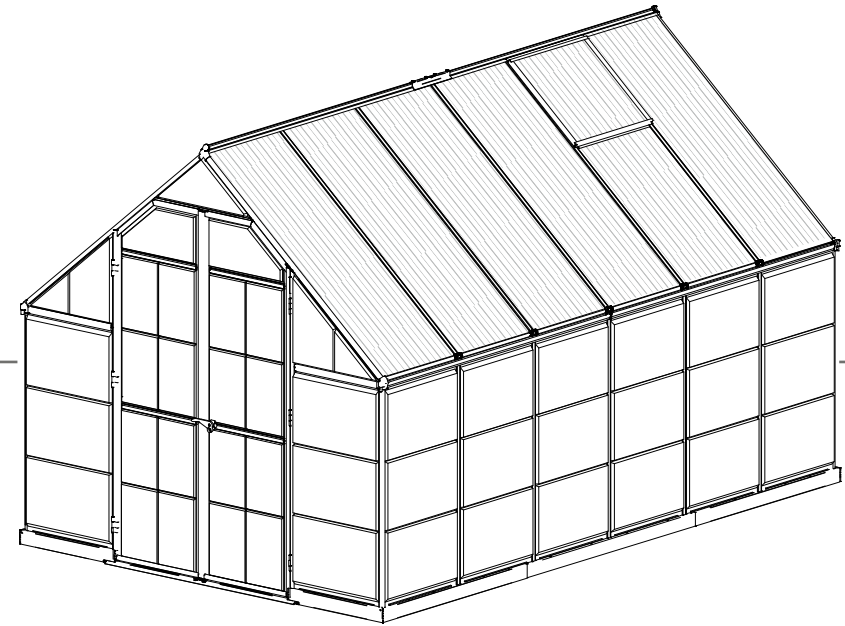

IMPORTANT

Please read these instructions carefully before you start to assemble this greenhouse. Keep these instructions in a safe place for future reference.

⇒ Customer Service

For assistance with assembly or for replacement parts – please log onto our website or call our service line (number is on the title page).

Additional information can be found at our website: www.palamapplications.com

⇒ Safety Advice

- It is of utmost importance to assemble all of the parts according to the directions. Do not skip any step.
- We strongly recommend using work gloves during assembly.
- Always wear shoes and safety goggles when working with extruded aluminium.
- If using a step ladder or power tools ensure that you follow the manufacturer's safety advice.
- Do not touch overhead power cables with the aluminium profiles.
- Do not attempt to assemble the greenhouse in windy or wet conditions.
- Dispose of all plastic bags safely keep them out of reach of small children.
- Keep children away from the assembly area.
- Do not lean against or push the greenhouse during construction.
- Do not position your greenhouse in an area exposed to excessive wind.
- Do not attempt to assemble this greenhouse if you are tired, have taken drugs or alcohol or if you are prone to dizzy spell.
- Hot items such as recently used grills, blowtorches etc. must not be stored in the greenhouse. Ensure there are no hidden pipes or cables in the ground before inserting the pegs.
- This product is designed to use as greenhouse only.

⇒ Care & Maintenance

When your greenhouse needs to be cleaned, use a mild detergent solution and rinse with cold clean water. DO NOT use acetone, abrasive cleaners or other special detergents to clean the clear panels. It is recommended to check periodically that roof panels caps (plastic part 329 & profile 981) are set in place.

⇒ Tools & Equipment

- Tape measure
- Work gloves
- Lubricant
- Phillips head screwdriver
- Step ladder
- Drill bit
- Large hammer
- Spanner
- T001 - Special tool for Screws 411 and nuts 412



⇒ Before Assembly

This is a multi-part assembly best achieved by two people. Allow at least half a day for assembly process.

Selecting a site - the greenhouse must be positioned and fixed on a flat level surface.

Choose a sunny position away from overhanging trees.

We are strongly recommend to fix your greenhouse directly to a solid concrete foundation. When doing that use the pre drilled holes in the metal base supplied.

Take out all components parts of the packages. Sort the parts and check against the contents parts list.

During assembly parts should be laid out close at hand. Keep all small parts (screws etc.) in a bowl so they do not get lost.

In purpose to facilitate parts' identification and assembly process, all-positioned profiles are used in this greenhouse. As a result some apertures in the profiles are not used during assembly.

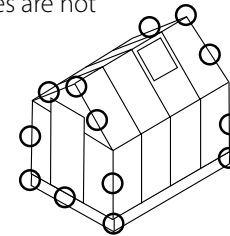

⇒ During Assembly

Carry out the assembly steps in the order set out in the instructions.

Step 1: Make sure the base is square by measuring the diagonals and level by using a spirit level.

Step 5: Part 7063 is the greenhouse threshold. Fixing it determines the front side of the greenhouse.

Steps 8: The oval hole in the crossbars A256 should always be assembled to the base of the greenhouse.

Steps 47: Decide on the windows' location before assembly. Windows can be installed in two of the indicated options.

Step 79: Firmly connect the greenhouse to a level final position immediately after completion of the assembly.

- **Screws 411 and nuts 412 are used throughout the assembly process.**
- Screws 411 are to be assembled from the outside and nuts 412 from the inside of the greenhouse.
- If not specified otherwise, do not fasten screws and nuts (411 & 412) more than 2-3 turns only. Do not tighten them until completion of the panels' assembly. These 2 icons indicate if screws' tightening is required or not.
- However, in some steps, temporary tightening of a few screws may be needed to prevent a profile from falling till it will be fully connected in the next steps.

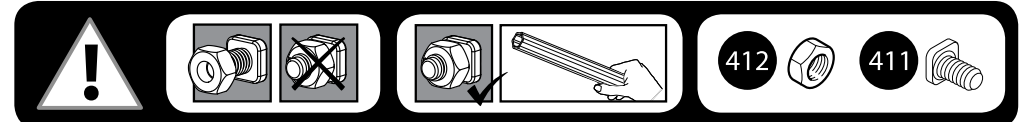

IMPORTANT !

Veillez lire attentivement ces instructions avant de commencer à monter votre serre. Conservez ces instructions en lieu sûr pour toute consultation ultérieure.

⇒ **Service clientèle**

Pour toute assistance concernant le montage de la serre ou ses pièces de rechange – veuillez consulter notre site Internet ou appeler notre service technique (dont le numéro de téléphone figure sur la couverture de la brochure).

Pour en savoir plus, n'hésitez pas à visiter notre site Internet : www.palramapplications.com

⇒ **Consignes de sécurité**

- Très important ! Veuillez suivre scrupuleusement les instructions de cette brochure et réaliser les étapes dans l'ordre énoncé.
- Nous recommandons vivement le port de gants de protection pendant le montage.
- Portez toujours des chaussures de travail et des lunettes de protection lorsque vous travaillez des pièces en aluminium extrudé.
- Lors de l'utilisation d'une échelle ou d'outils électriques, assurez-vous de bien suivre les consignes de sécurité du fabricant.
- Veillez à ne pas toucher de câbles aériens avec les profilés en aluminium.
- N'essayez pas de monter la serre s'il y a du vent ou s'il fait humide.
- Jetez tous les sacs en plastique en appliquant les règles de sécurité et maintenez-les hors de portée des jeunes enfants.
- Eloignez les enfants de la zone d'assemblage.
- Ne vous appuyez pas contre la serre et ne la poussez pas pendant le montage.
- Ne positionnez pas la serre dans un endroit trop exposé au vent.
- N'essayez pas de monter la serre si vous êtes fatigué, si vous êtes sous l'effet de drogues, de médicaments ou d'alcool ou encore si vous êtes sujet aux vertiges.
- Les objets chauds tels qu'un barbecue, un chalumeau ou autre article ayant été récemment utilisés, ne doivent pas être rangés dans la serre.
- Avant de planter les piquets, assurez-vous qu'aucun tuyau ni câble n'est enterré à l'endroit sélectionné pour l'installation.
- Ce produit est conçu pour servir de serre exclusivement.

⇒ **Entretien & Maintenance**

Pour nettoyer votre serre, utilisez une solution détergente douce et à rincez à l'eau claire et froide. NE PAS utiliser d'acétone ni de produits nettoyants ou autres détergents spéciaux pour nettoyer les panneaux clairs. Il est recommandé de vérifier régulièrement que les couvre-joints des panneaux du toit sont bien en place (pièces en plastique 329 & profilé 981).

⇒ **Outils & Equipement**

- Mètre (ruban)
- Gants de travail
- Lubrifiant
- Tournevis cruciforme (Philips)
- Escabeau
- Perceuse
- Grand marteau
- Clé à écrous
- T001 – outil spécial pour vis 411 et écrous 412

⇒ **Avant le montage**

Il s'agit d'un assemblage à pièces multiples qu'il est préférable de réaliser à deux personnes et auquel il faut consacrer au moins une demi-journée.

Sélection du site – la serre doit être montée et fixée sur une surface plane.

Choisissez un emplacement ensoleillé et éloigné d'éventuels arbres susceptibles de la surplomber.

Nous recommandons vivement de fixer la serre directement à de solides fondations en béton. Pour ce faire, utilisez les trous déjà percés dans le châssis métallique fourni.

Sortez toutes les pièces de leurs emballages. Triez-les et comparez-les avec la liste des pièces pour vérifier que tout y est.

Lors de l'assemblage, les pièces doivent être disposées à portée de main. Gardez toutes les petites pièces (vis, etc.) dans un récipient pour éviter de les perdre.

Pour faciliter l'identification des pièces et la procédure de montage, les profilés utilisés pour la construction de cette serre sont tous déjà en place. En conséquence, certaines ouvertures des profilés restent inutilisées pendant le montage.

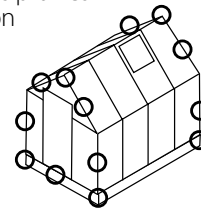
⇒ **Pendant le montage**

Procédez au montage étape par étape, en respectant l'ordre énoncé dans cette brochure.

Etape 1 : Assurez-vous que le châssis est bien carré en mesurant les diagonales, et vérifiez sa mise à niveau à l'aide d'un niveau à bulle.

Etape 5 : Partie 7063 est le seuil à effet de serre. Qu'il détermine la fixation de la face avant de l'effet de serre.

Etapes 8 : L'ouverture ovale des barres transversales A256 doit toujours être placée du côté du châssis de la serre.

Etapes 47 : Choisissez l'emplacement de la fenêtre avant le montage, parmi les options indiquées.

Etape 79 : Immédiatement après avoir terminé l'assemblage, fixez solidement la serre en position finale, parfaitement horizontale.

Les vis 411 et écrous 412 servent tout au long de la procédure.

- Les vis 411 se placent à l'extérieur et les écrous 412 à l'intérieur de la serre.
- S'il n'est pas spécifié autrement, Ne serrez les vis et écrous (411 & 412) que de 2 à 3 tours, pas plus. Ne les serrez pas tant que l'assemblage n'est pas complètement terminé, sauf indication contraire. Ces deux icônes indiquent si le serrage des vis est nécessaire ou non.
- Cependant, la réalisation de certaines étapes peut nécessiter le serrage provisoire de quelques vis pour empêcher un profilé de tomber en attendant qu'il soit entièrement intégré à l'ensemble de la structure dans les étapes suivantes.

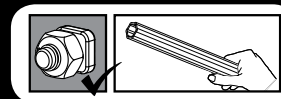
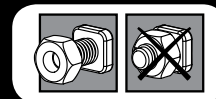

412



411



WICHTIG

Bitte lesen Sie diese Anweisungen sorgfältig durch, bevor Sie mit dem Aufbau des Gewächshauses beginnen.
Heben Sie diese Anweisungen an einem sicheren Ort auf, um später auf sie zurückgreifen zu können.

⇒ Kundendienst

Für Hilfe bei dem Aufbau oder für Ersatzteile – können Sie sich entweder auf unserer Webseite einloggen oder unseren Kundendienst anrufen (die Nummer steht auf der Titelseite).

Weitere Informationen finden Sie auf unserer Webseite: www.palramapplications.com

⇒ Sicherheitshinweise

- Es ist von grösster Wichtigkeit, alle Teile genau gemäss den Anweisungen zusammenzubauen. Lassen Sie keinen Schritt aus.
- Wir empfehlen wärmstens, während des Aufbaus Arbeitshandschuhe zu tragen.
- Tragen Sie immer Schuhe und eine Schutzbrille, wenn Sie mit stranggepresstem Aluminium arbeiten.
- Wenn Sie eine Stufenleiter oder Elektrowerkzeuge benutzen, achten Sie darauf, die Sicherheitshinweise des Herstellers zu befolgen.
- Berühren Sie mit den Aluminiumprofilen keine Oberleitungen.
- Versuchen Sie nicht, das Gewächshaus bei windigem oder regnerischem Wetter zusammenzubauen.
- Entsorgen Sie alle Plastiktüten sicher und bewahren sie ausserhalb der Reichweite von kleinen Kindern auf.
- Halten Sie Kinder vom Aufbaubereich fern.
- Während des Aufbaus sollten Sie sich nicht gegen das Gewächshaus lehnen oder es drücken.
- Bauen Sie Ihr Gewächshaus nicht an Orten mit hoher Windbelastung auf.
- Versuchen Sie nicht, dieses Gewächshaus aufzubauen wenn Sie müde sind, unter dem Einfluss von Drogen oder Alkohol stehen oder zu Schwindelanfällen neigen.
- Heisse Geräte wie kürzlich benutzte Grills, Schneidbrenner usw. dürfen nicht im Gewächshaus gelagert werden. Vergewissern Sie sich vor Einsetzen der Pflöcke, dass sich keine versteckten Rohre oder Kabel im Boden befinden.
- Dieses Produkt ist nur für den Einsatz als Gewächshaus geeignet.

⇒ Pflege und Wartung

Benutzen Sie eine milde Reinigungslösung für die Reinigung Ihres Gewächshauses und spülen es danach mit kaltem, sauberem Wasser ab. Benutzen Sie AUF KEINEN FALL Azeton, Scheuermittel oder andere spezielle Reinigungsmittel, um die klaren Platten zu reinigen.

⇒ Werkzeuge & Ausrüstung

- Maßband
- Arbeitshandschuhe
- Plastik- oder Gummihammer
- Schmiermittel
- Kreuzschitzschraubenzieher
- Stufenleiter
- Bohrer
- Grosser Hamme

- Schere
- Schlüssel
- T001

**⇒ Vor dem Zusammenbau**

Diese ist eine Mehrteilige Montage. Der Zusammenbau der Teile wird am besten von zwei Leuten bewältigt. Rechnen Sie mit mindestens einem halben Tag für den Zusammenbau.

Wahl des Standorts - das Gewächshaus muss auf einem flachen ebenen Untergrund aufgebaut und fixiert werden. Wählen Sie eine sonnige Stelle ohne überhängende Bäume.

Wir empfehlen Ihnen sehr Ihr Gewächshaus direkt auf einem soliden Betonfundament zu befestigen. Dazu sollten Sie die vorgebohrten Löcher in der gelieferten Metallbasis benutzen. Nehmen Sie alle Teile aus der Verpackung. Sortieren Sie die Teile und überprüfen Sie sie mit Hilfe der Inhaltsliste auf Vollständigkeit.

Während des Aufbaus sollten die Teile in Ihrer Nähe auf dem Boden ausgelegt werden. Bewahren Sie alle kleinen Teile (Schrauben usw.) in einer Schüssel auf, sodass sie nicht verloren gehen.

Um die Identifikation der Teile zu erleichtern und um die Montage zu vereinfachen, werden gleiche Profile in verschiedene Positionen eingebaut, sodass bei manchen Positionen einige Löcher dieser Profile während der Montage nicht verwendet werden.

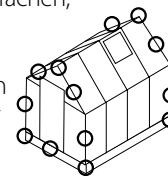
**⇒ Während des Zusammenbaus**

Führen Sie den Aufbau in der in den Gebrauchsanweisungen aufgeführten Reihenfolge Schritt per Schritt aus.

Schritt 1: Vergewissern Sie sich, dass die Basis sowohl quadratisch als auch waagrecht ist, indem Sie die Diagonalen messen und die Basis mit einer Wasserwaage prüfen.

Schritt 5: Teil 7063 sind in der Rückseite des Gewächshauses und deren Festsetzung bestimmt die Vorderseite des Gewächshauses.

Schritte 8: Das ovale Loch in den Querbalken A256 sollte immer auf die Basis des Gewächshauses montiert werden.

Schritte 47: Entscheiden sie über die genaue Lageposition des Fensters vor dessen Einbau. Das Fenster kann in einer der angegebenen Optionen installiert werden.

Schritt 79: Befestigen Sie das Gewächshaus auf eine endgültige Position direkt nach Beendigung des Aufbaus auf einem waagrechten Untergrund.

Les vis 411 et écrous 412 servent tout au long de la procédure.



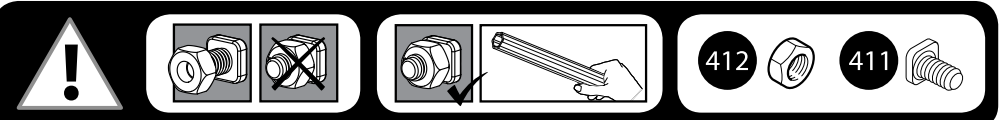





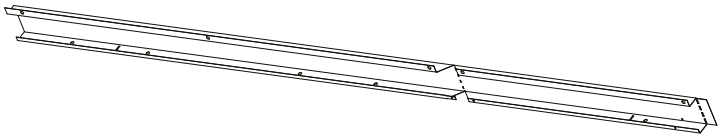

- Les vis 411 se placent à l'extérieur et les écrous 412 à l'intérieur de la serre.
- S'il n'est pas spécifié autrement, Ne serrez les vis et écrous (411 & 412) que de 2 à 3 tours, pas plus. Ne les serrez pas tant que l'assemblage n'est pas complètement terminé, sauf indication contraire. Ces deux icônes indiquent si le serrage des vis est nécessaire ou non.
- Cependant, la réalisation de certaines étapes peut nécessiter le serrage provisoire de quelques vis pour empêcher un profilé de tomber en attendant qu'il soit entièrement intégré à l'ensemble de la structure dans les étapes suivantes.

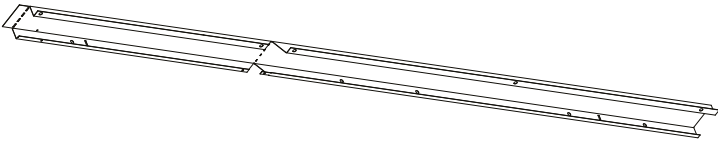

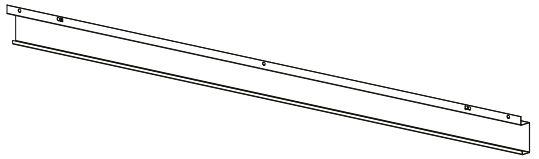
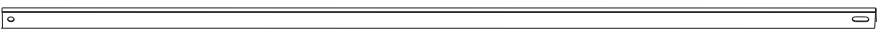
Contents

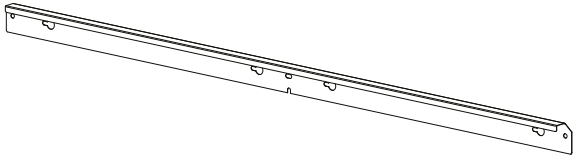
Item	Inc./cm	Qty.	Item	Inc./cm	Qty.
7071		1	7069		2
7073		10	7070		2
993		10	972		4
7068		4	973		2
983		1	994		1
			7075		1
			995		1
			7074		1

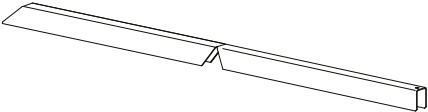
Contents

Item	Inc./cm	Qty.	Item	Inc./cm	Qty.
996		4	7058		2
7076		4	7059		2
966		6	7060		3
256		8	7063		2
991		2	7061		1
990		2	7062		2
989		2			
981		12			









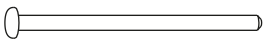

Contents

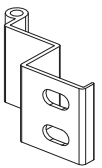
Item	Inc./cm	Qty.	Item	Qty.	Item	Qty.	Item	Qty.
7064		1	286	4	7082	2	318 (PVC)	24 (+4)
7072		6	06	1	7067	2	7009 (PVC)	4 (+1)
992		4	07	1	96	6	328	37
984		2	08	2	7066	2	292	2
3017		4	288	10	459	3	456	6
			7065	1	T001	1	926	6

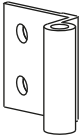
Contents

Item	Qty.	Item	Qty.	Item	Qty.	Item	Qty.	Item	Qty.
7083	1	343	2	7011	16	7081	1	7079	2
7084	1	329	10	559	3	7080	1	586	2
7085	1	344L	2	560	3	7086	1	7078	10
7086	1	344R	2	567	4	7088	1		
7088	1	99	2	570	1	M4 x 50mm			
423	1	22	4	7077	2	M4			

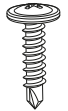
Contents

Item	Qty.	Item	Qty.
 463	6	 411 M6	207 (+14)
 462	6	 461 M6	36 (+2)
 464	12	 412 M6	248 (+16)
 422 M4	28 (+2)	 447	8 (+1)
 465 M4	24 (+1)	 4008	24
 428 M4x10mm	4 (+1)	 411	10 (+1)

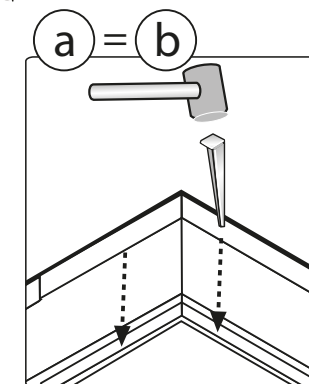
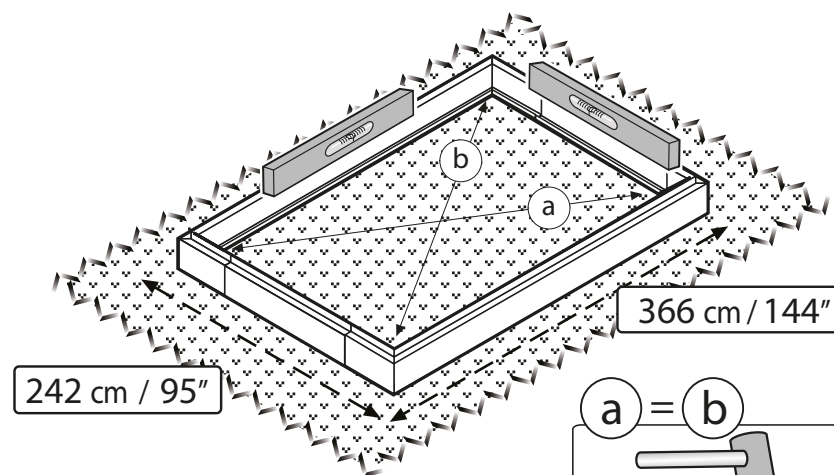
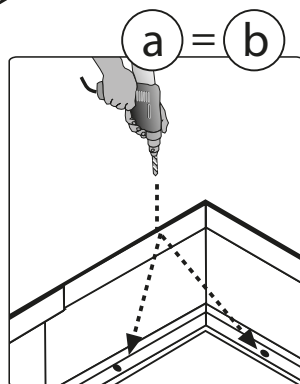
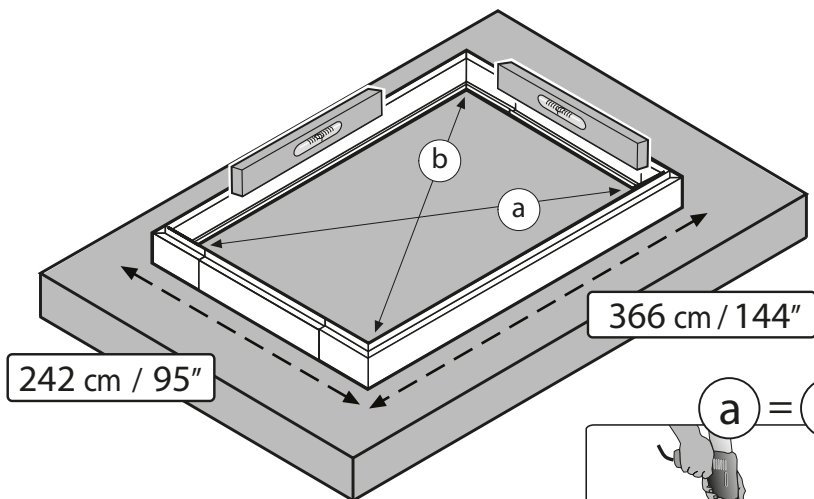
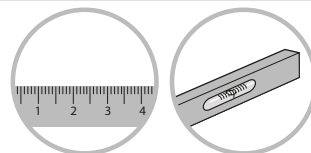
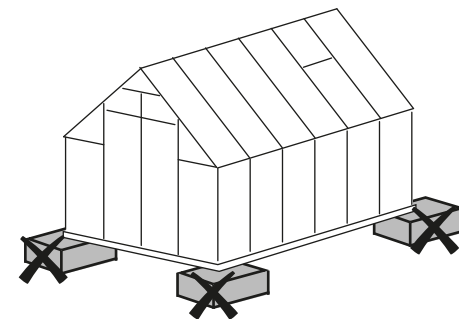
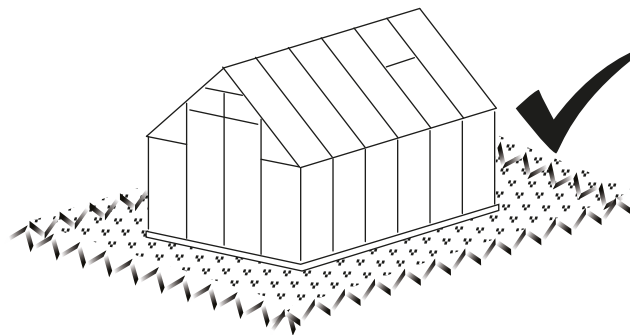
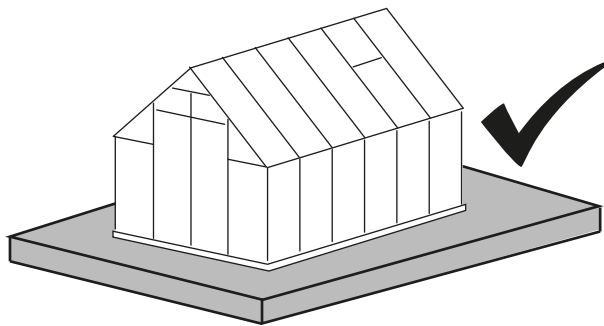

1

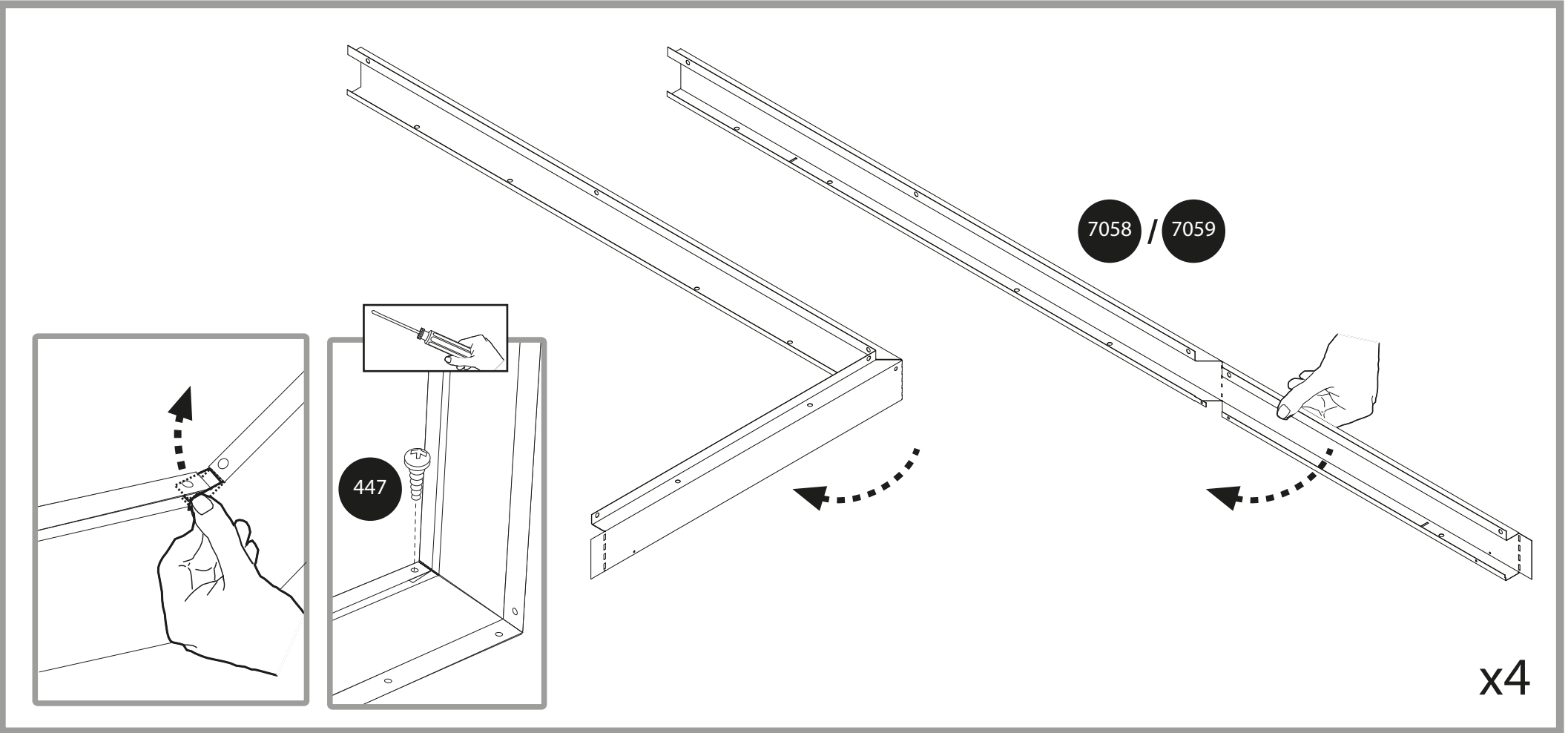
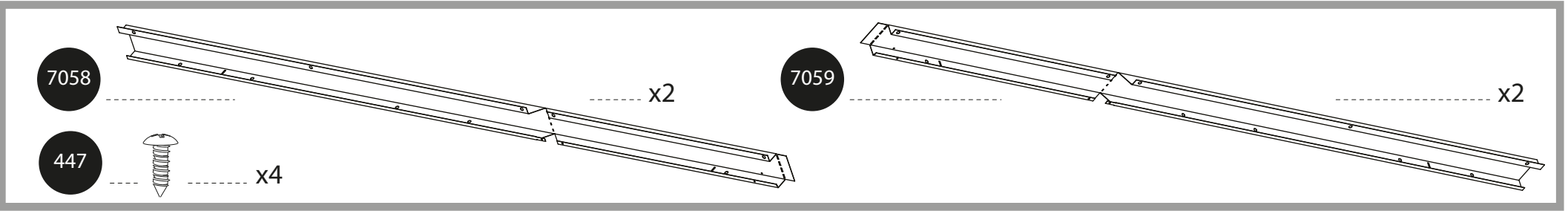
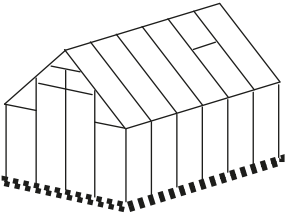

3

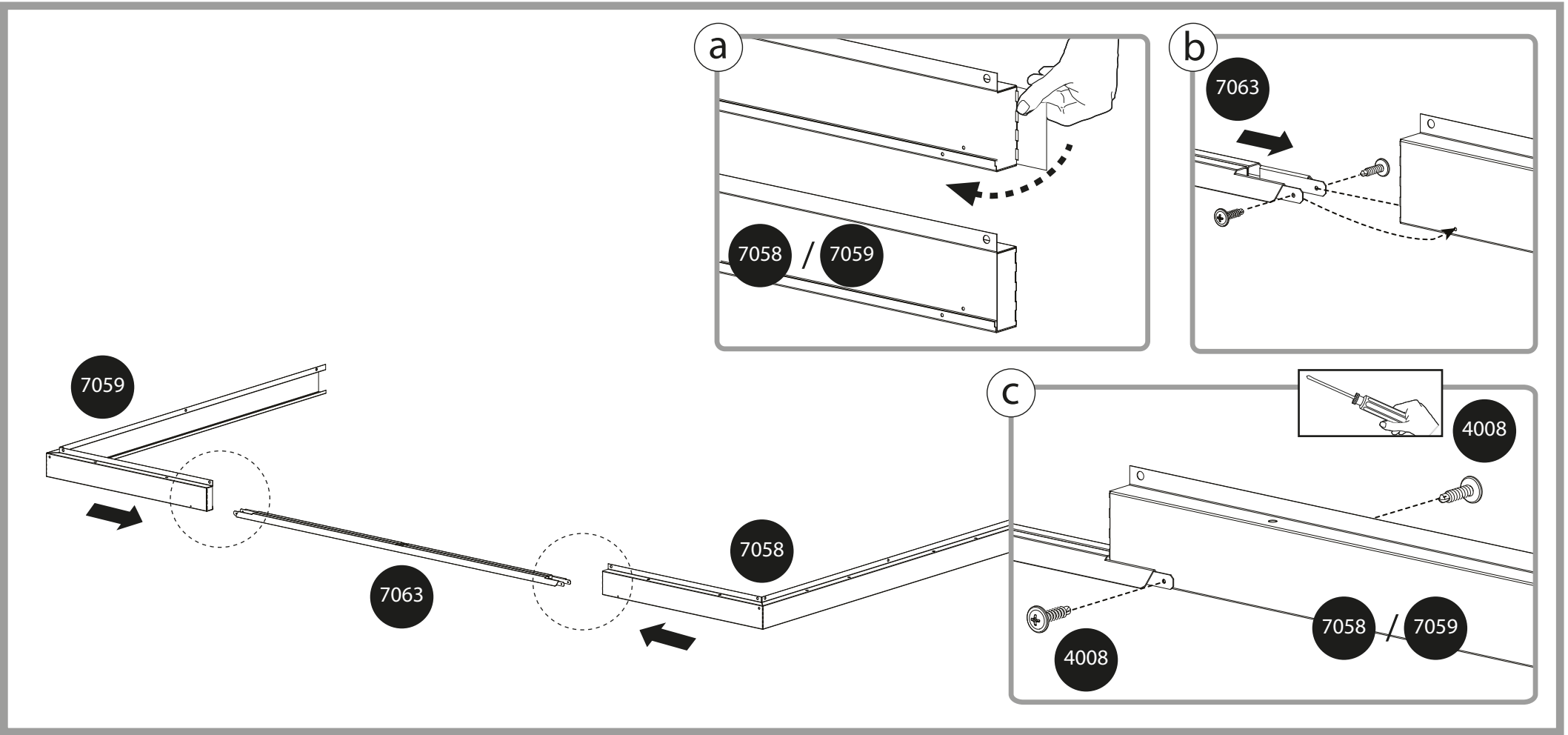
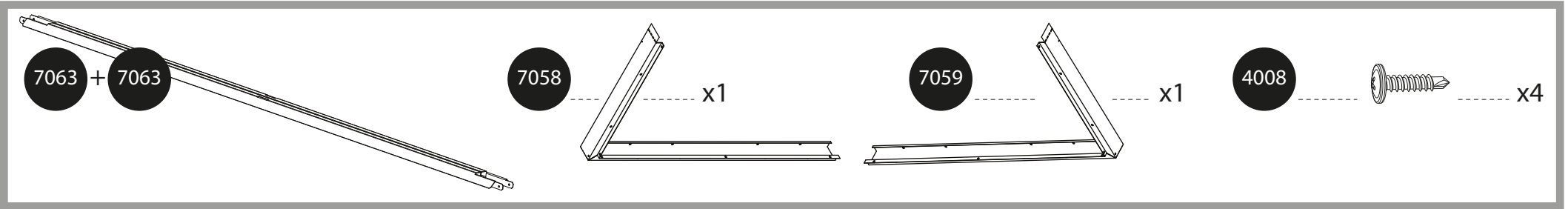
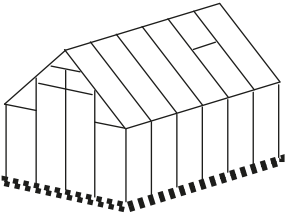

5

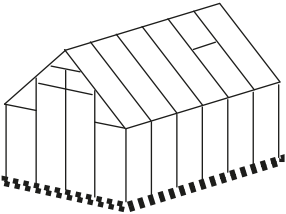

7060 x2

412 x4

411 x4

7060

7060

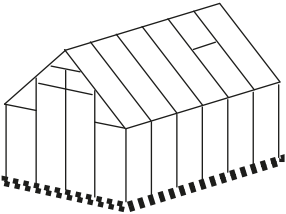

412



x13

411



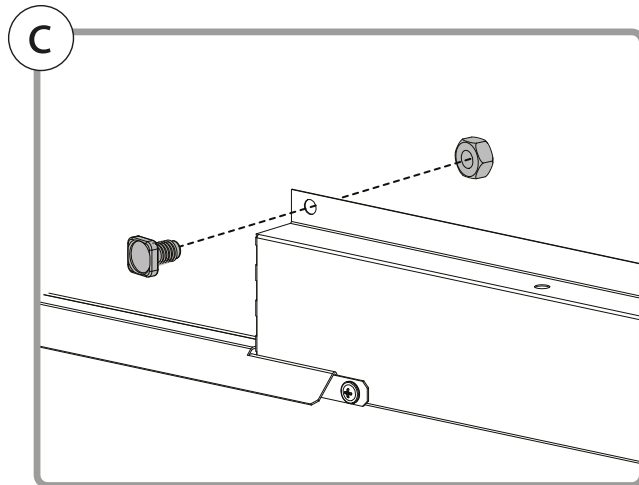
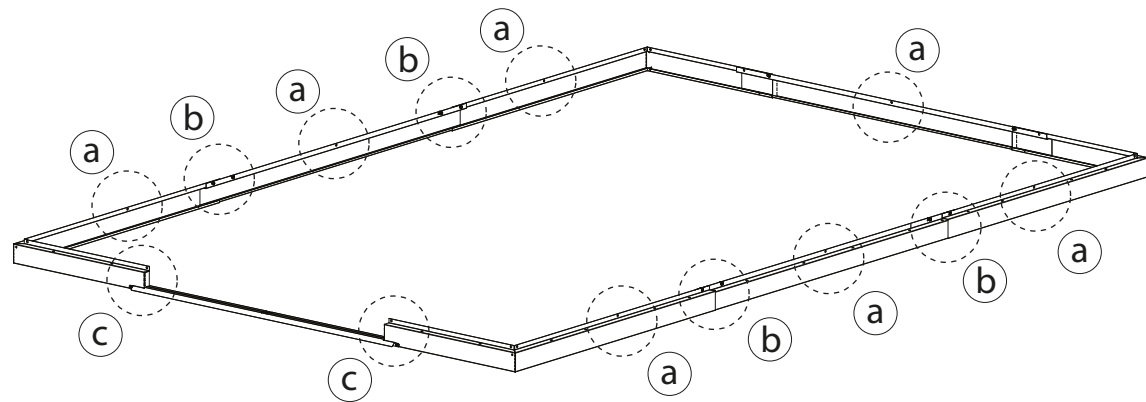
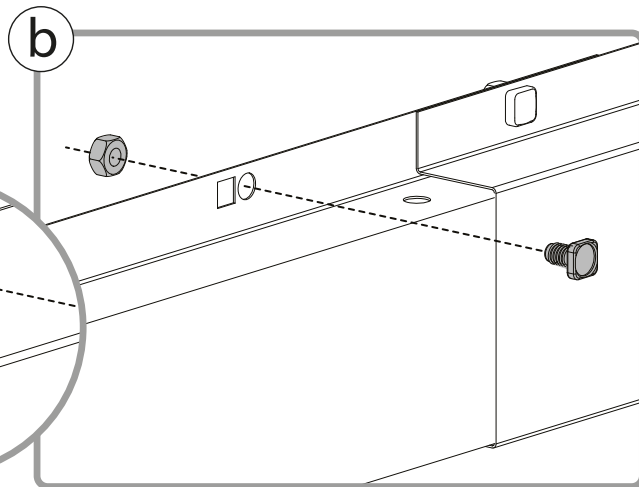
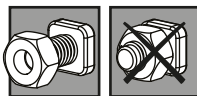
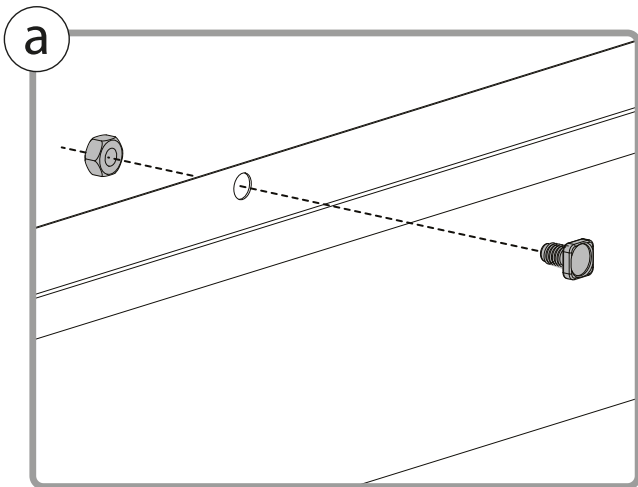

x13

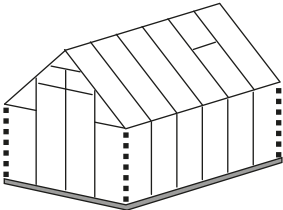



996  x4

412  x8

411  x8

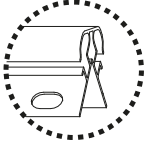

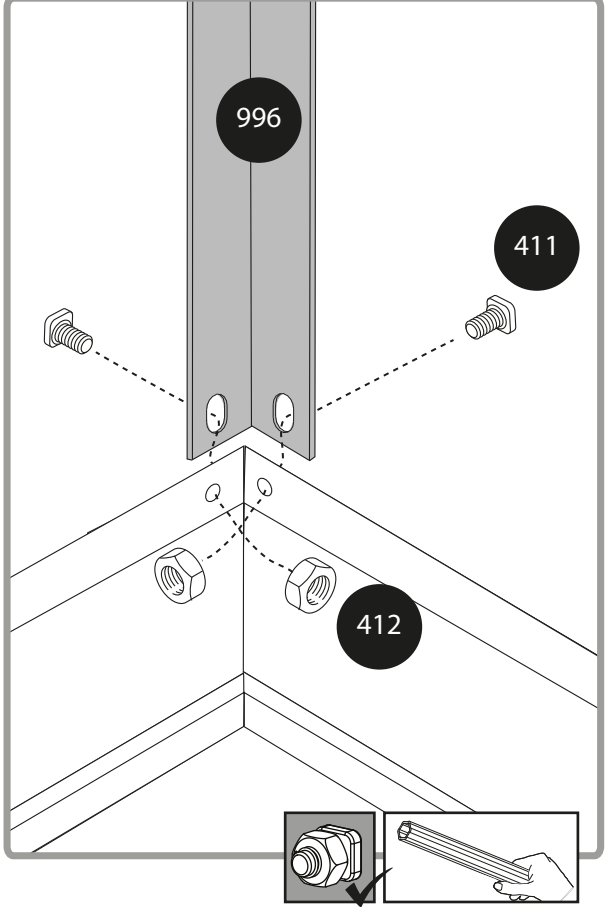
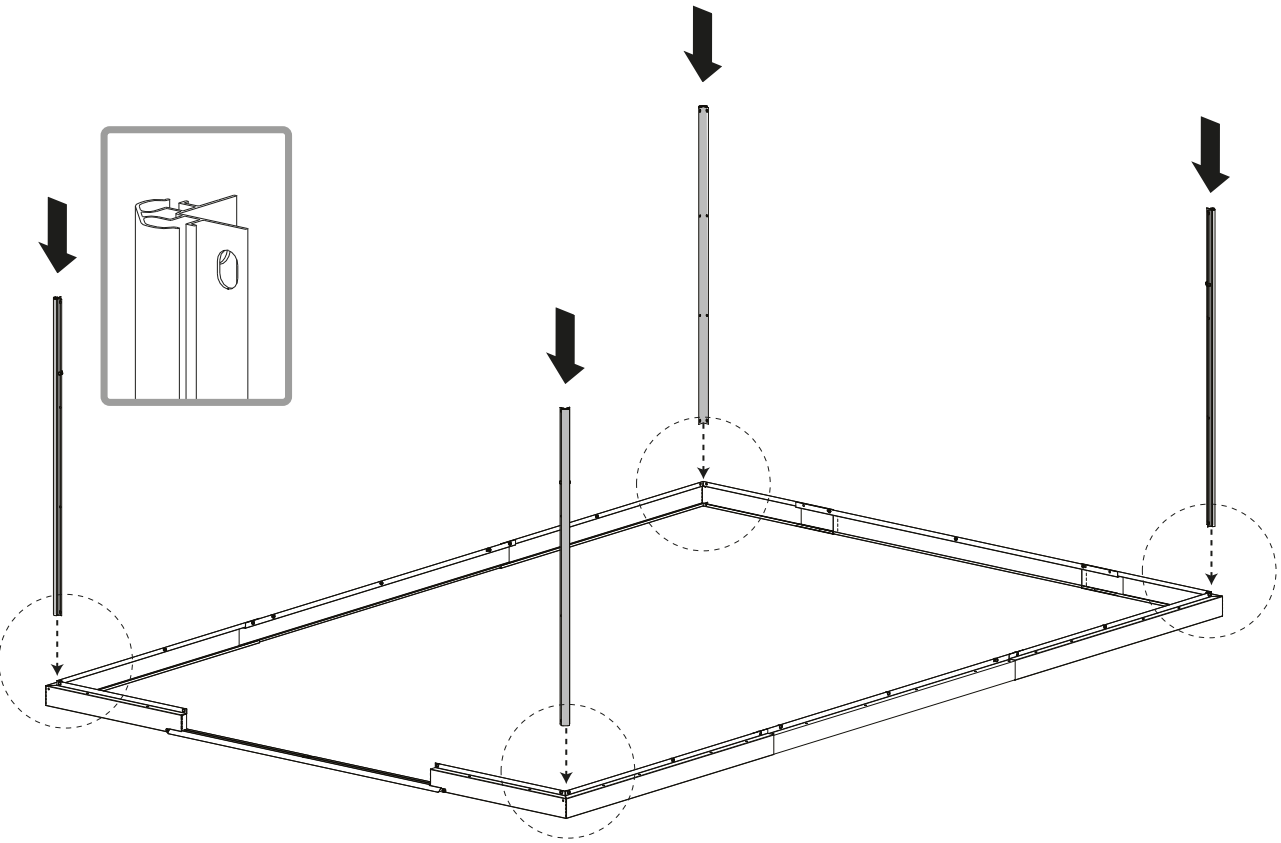

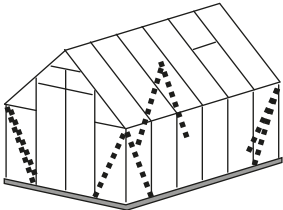

256  x8

412  x8 411  x8

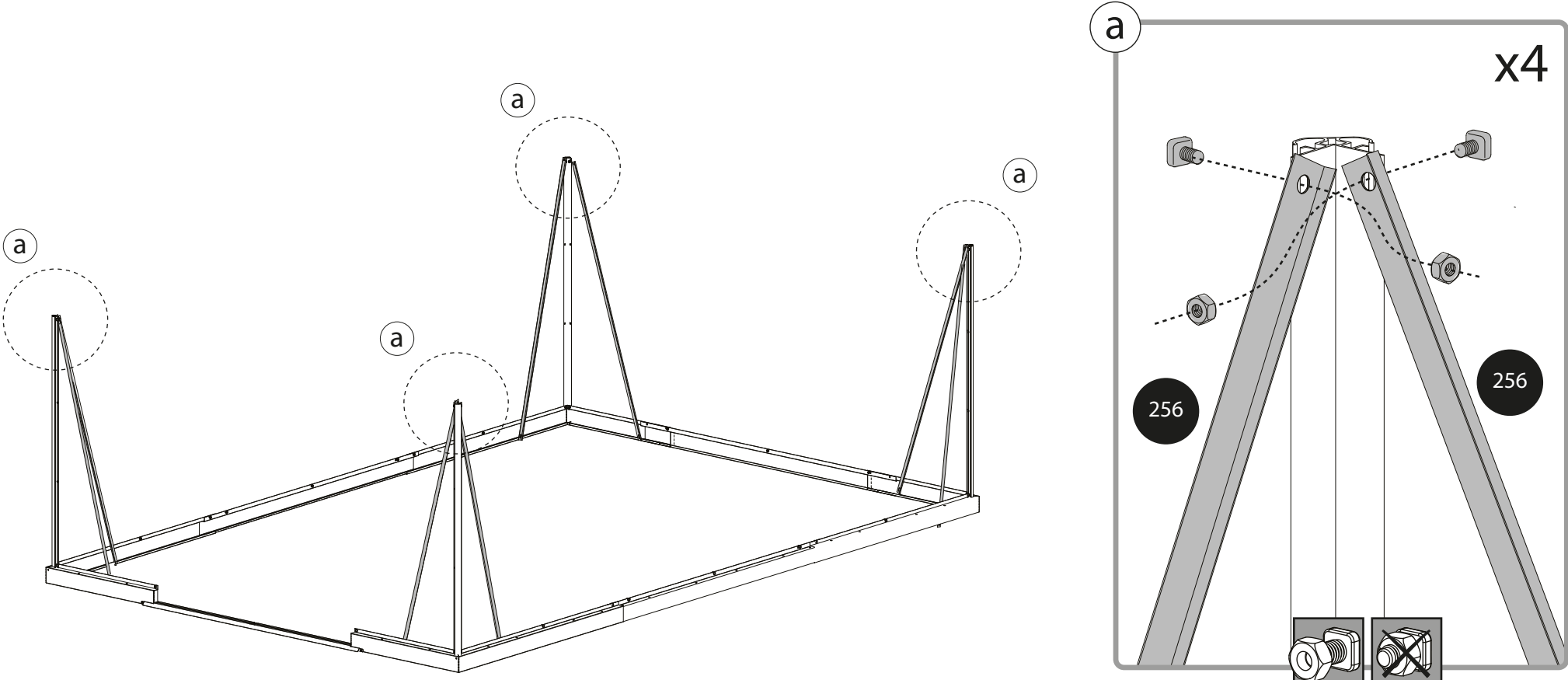

a

a

a

a

a



x4

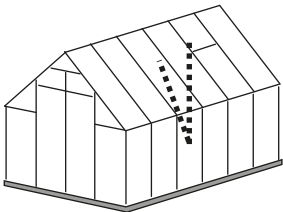

256

256





995   x1

412  x1 411  x1

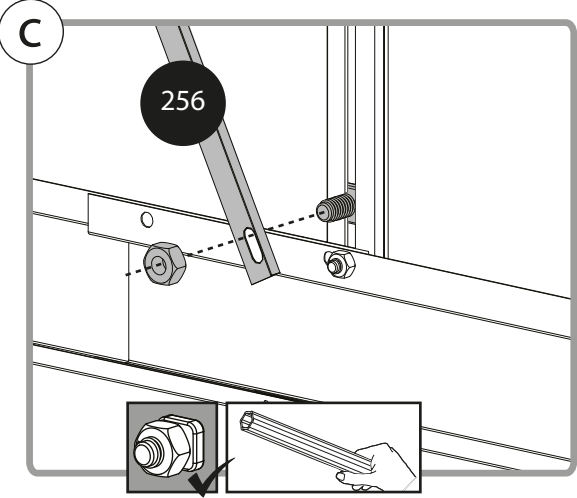
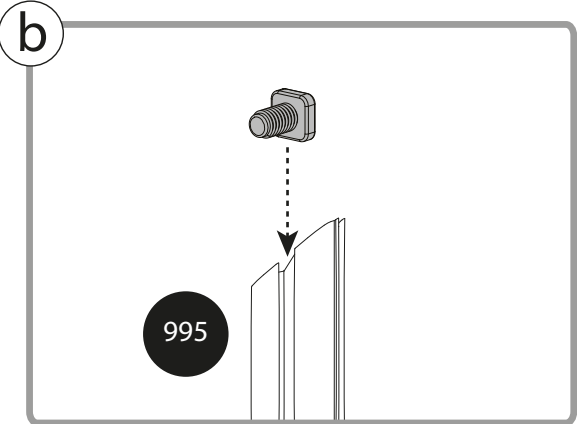
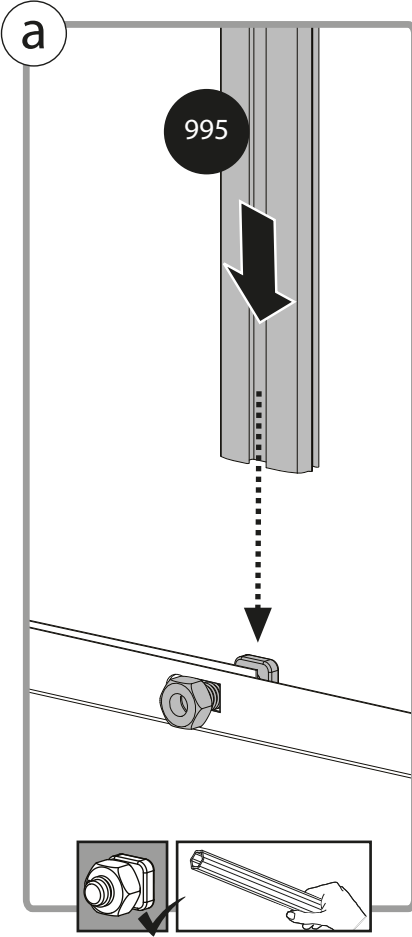
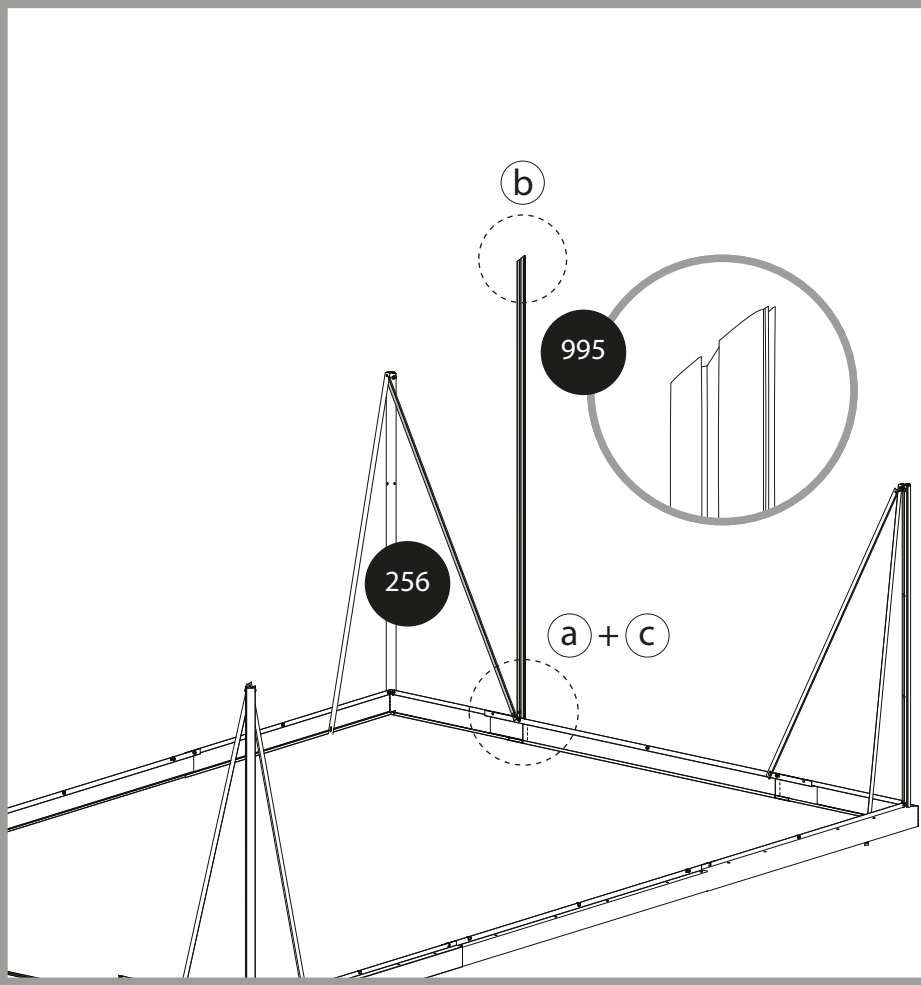

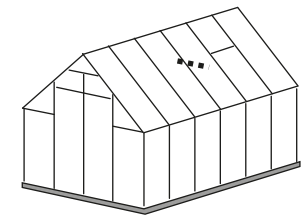

286

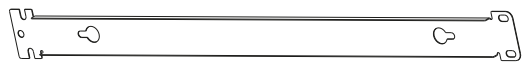

x1

412



x2

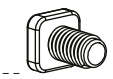

411



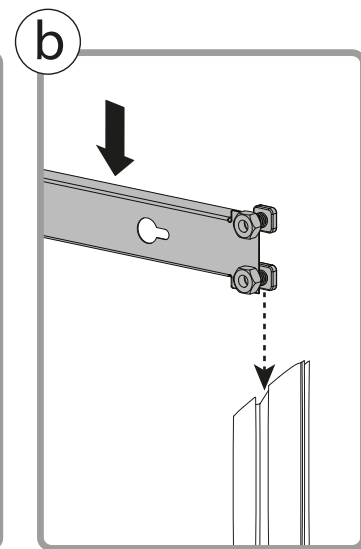
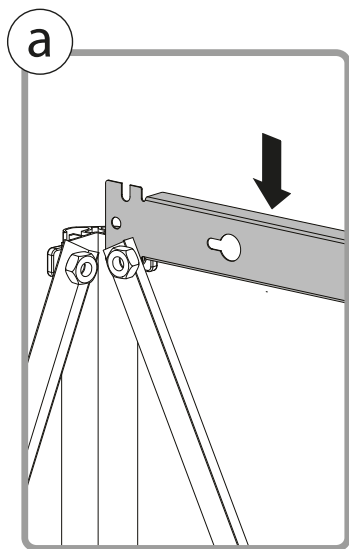
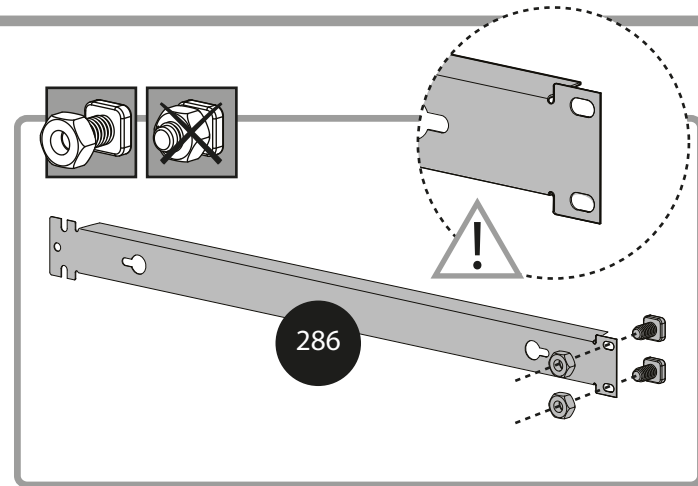
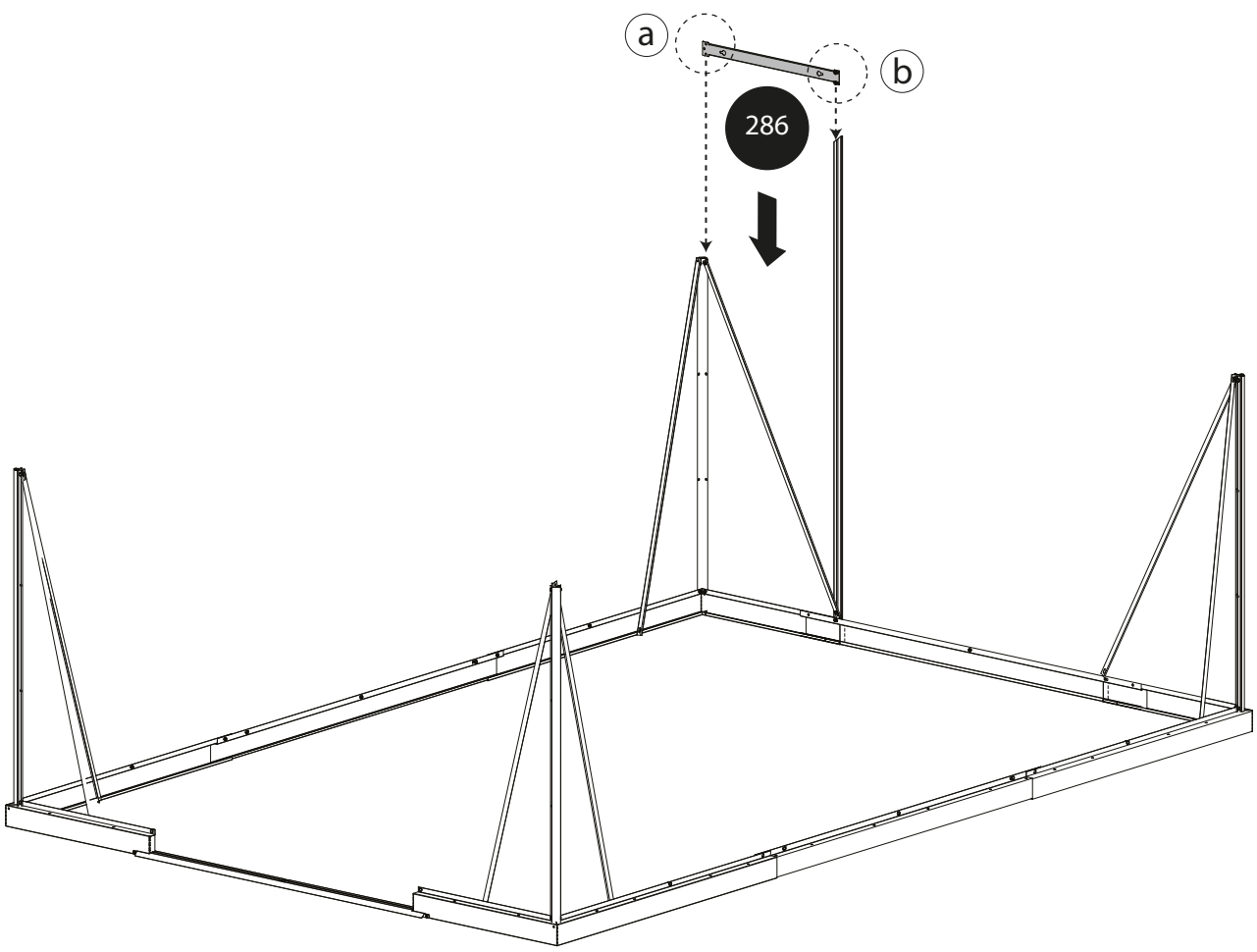

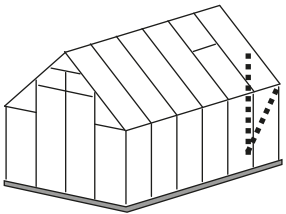
x2





994   x1

412  x1 411  x1

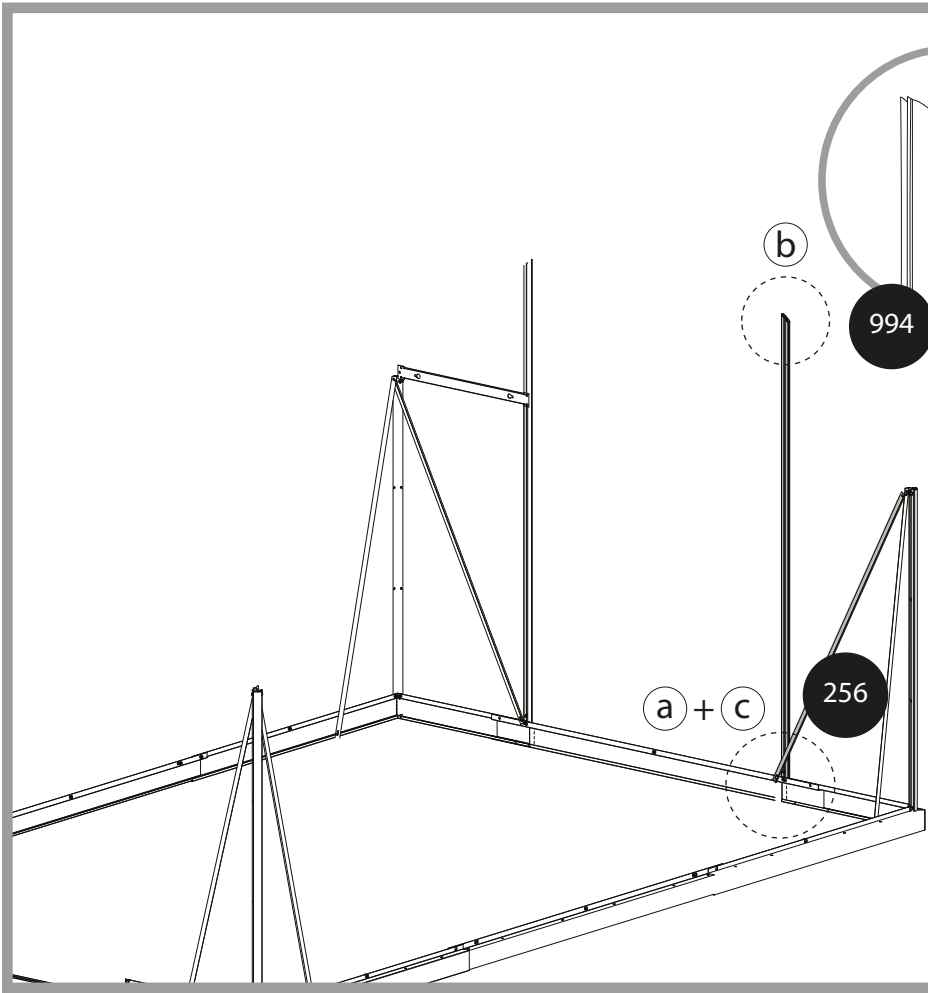

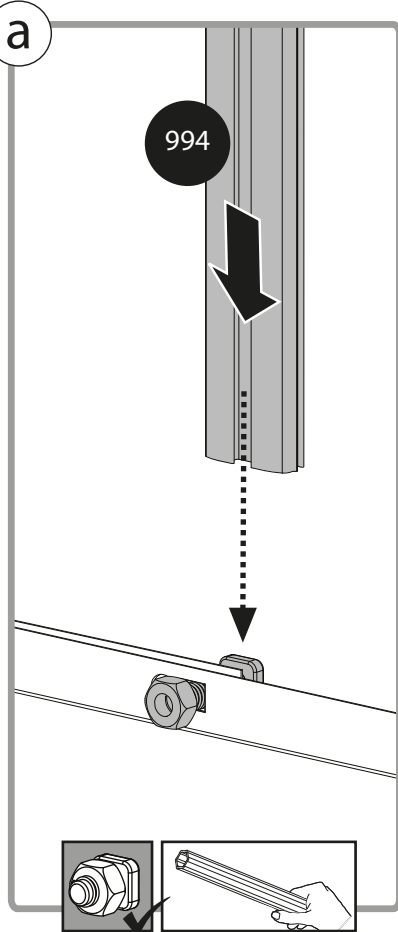

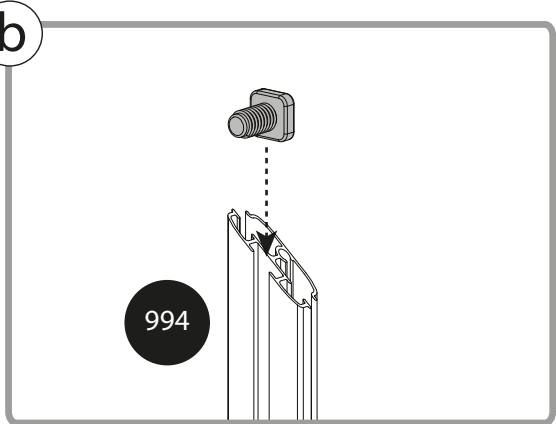
a  994

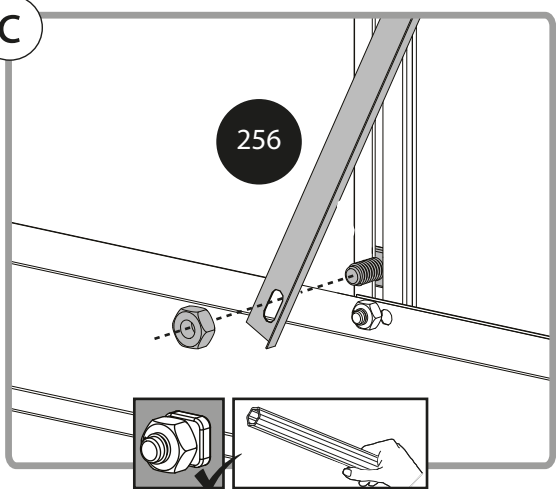
b  994

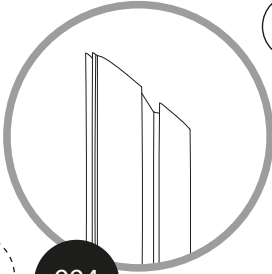
c  256

a + c  994

b  994

256 



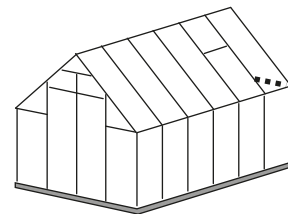

286

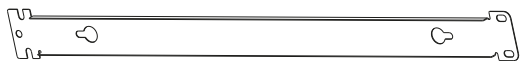

x1

412



x2

411



x2

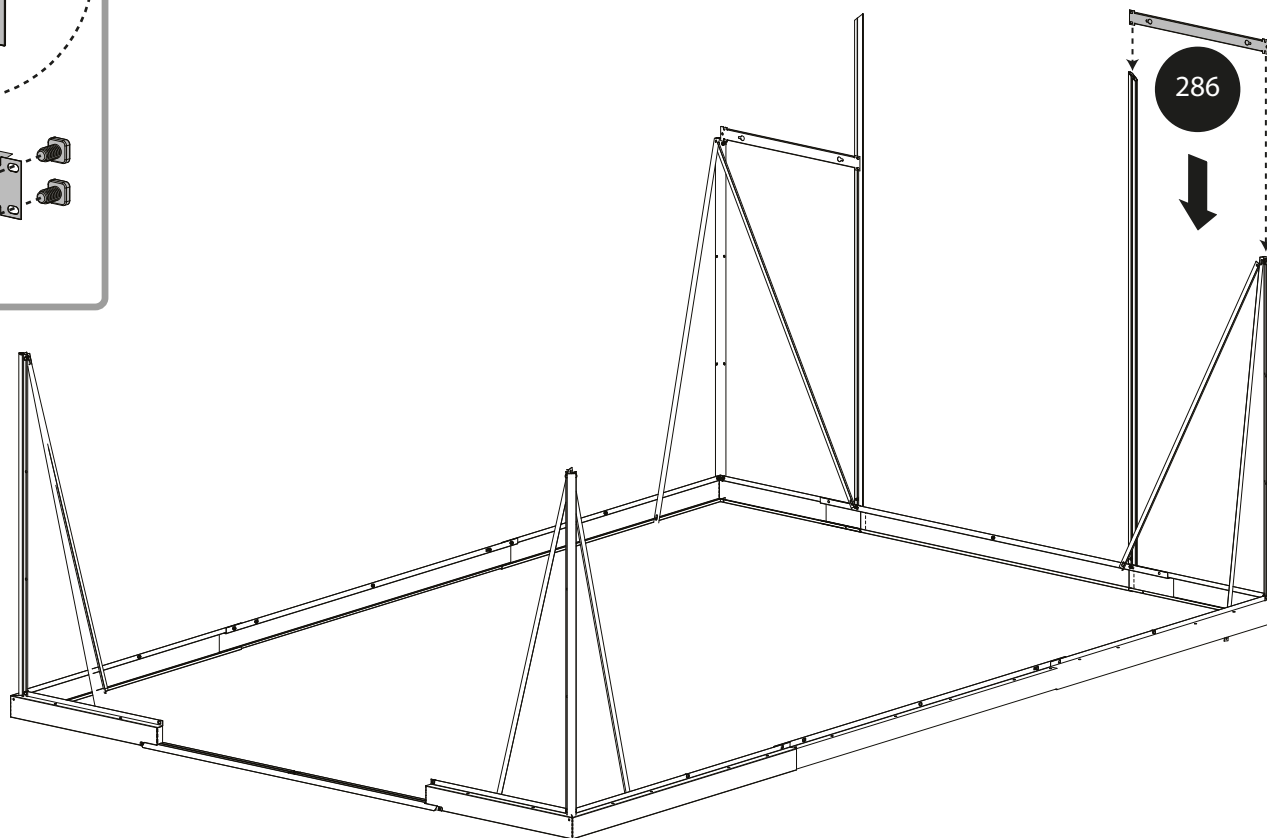
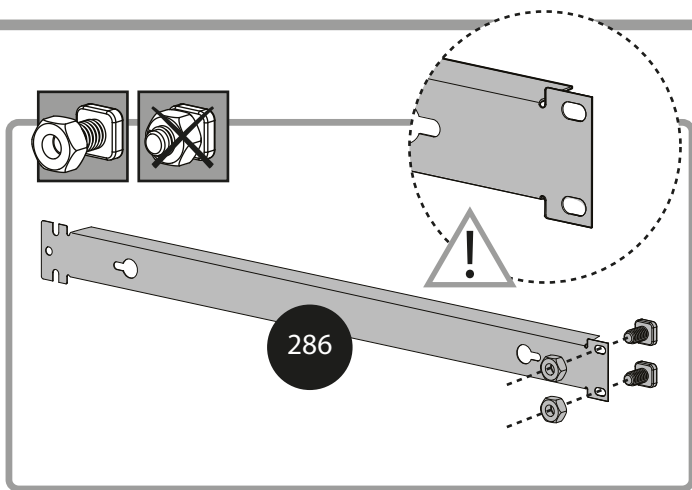

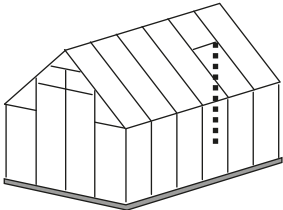

7071

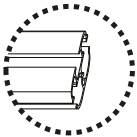

x1

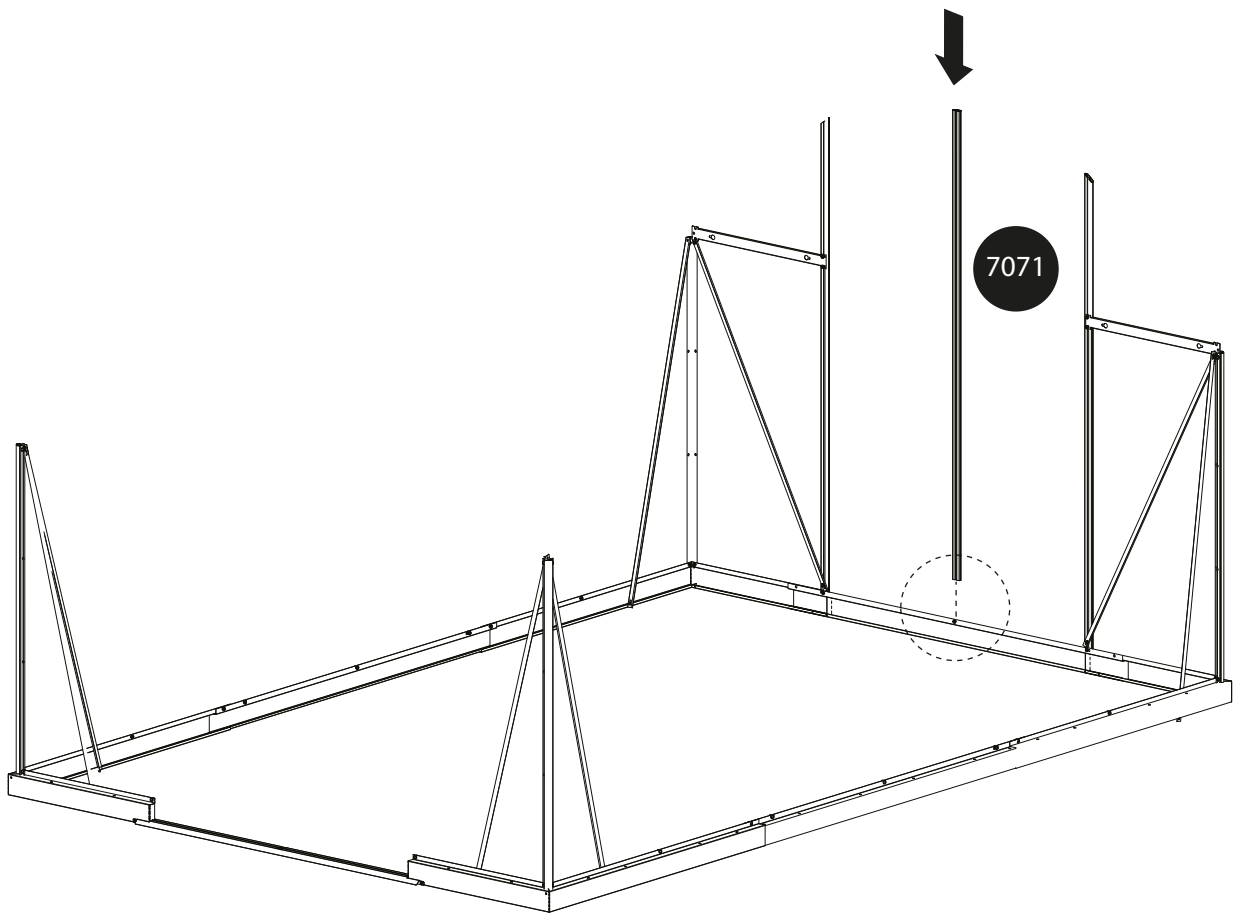

7071

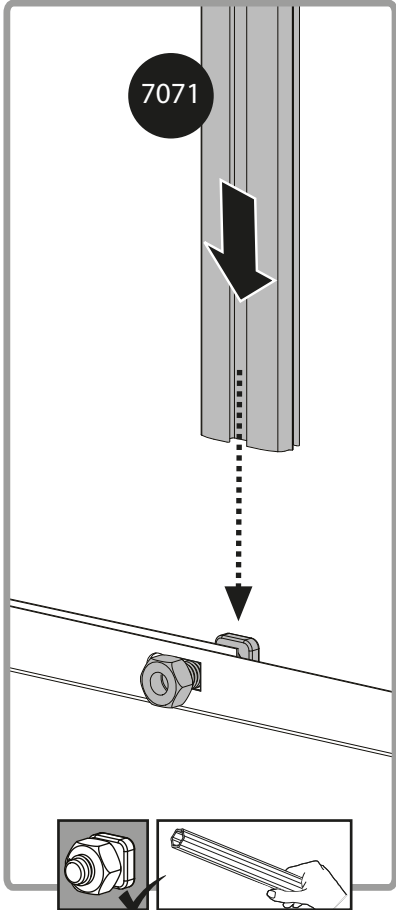

7071

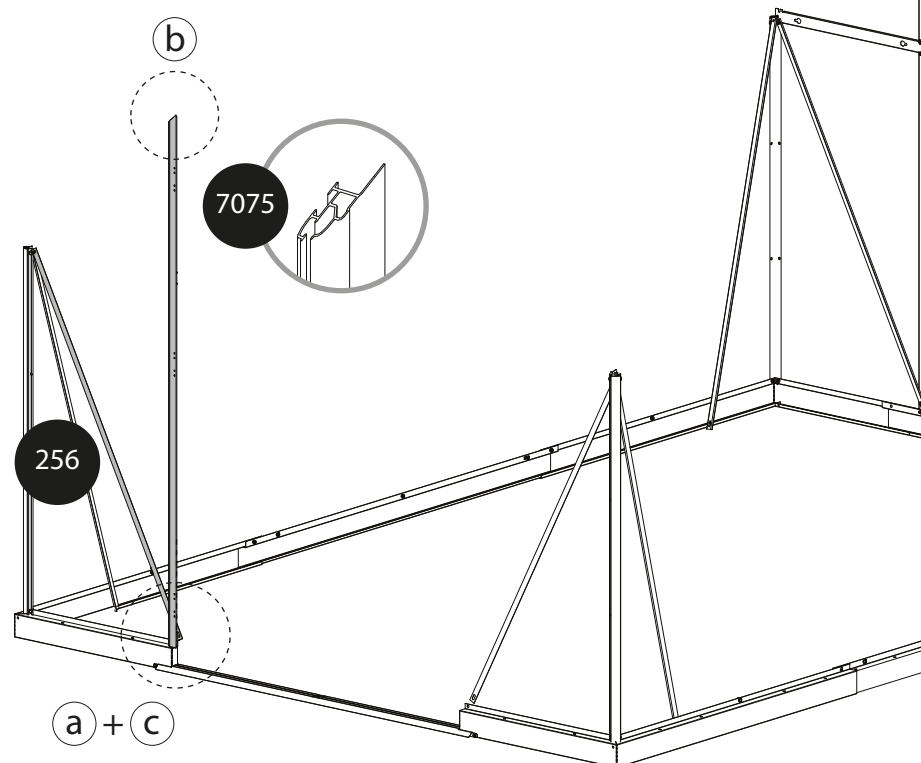
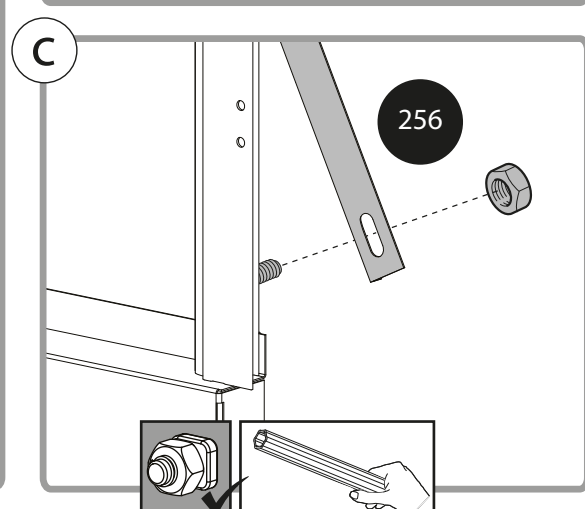
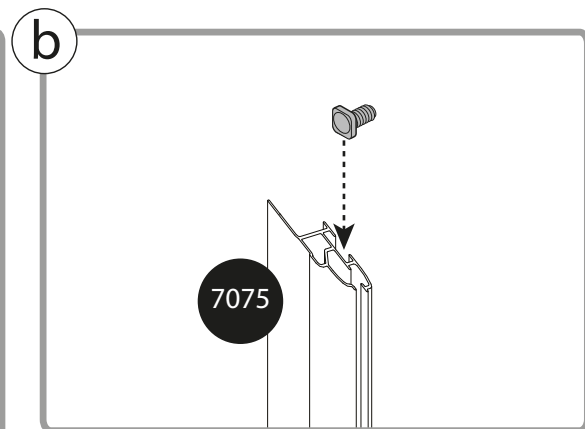
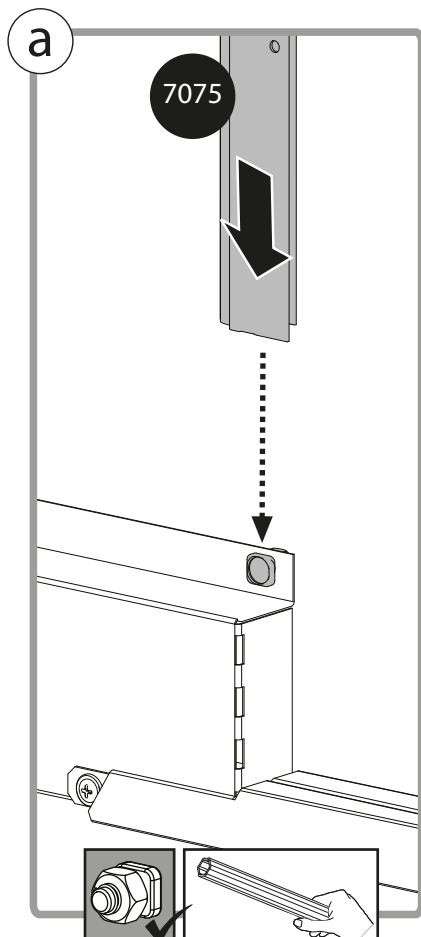
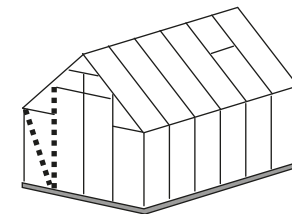

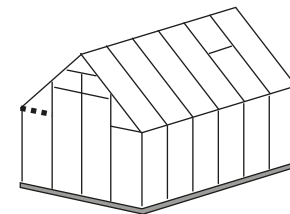

286



x1

412



x2

411



x2

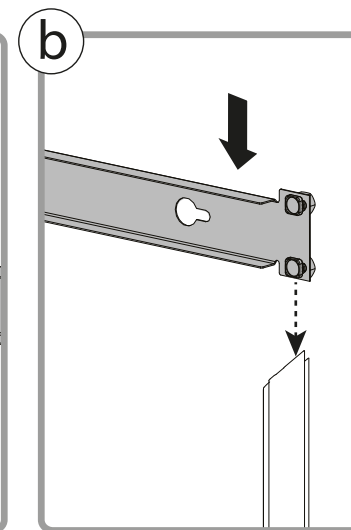
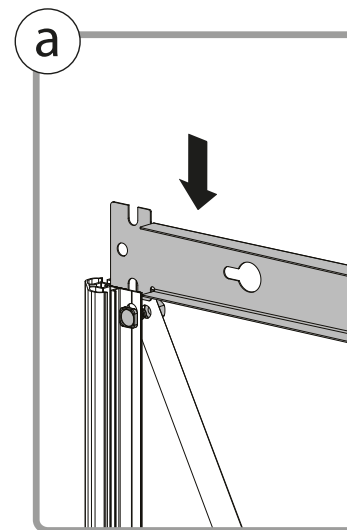
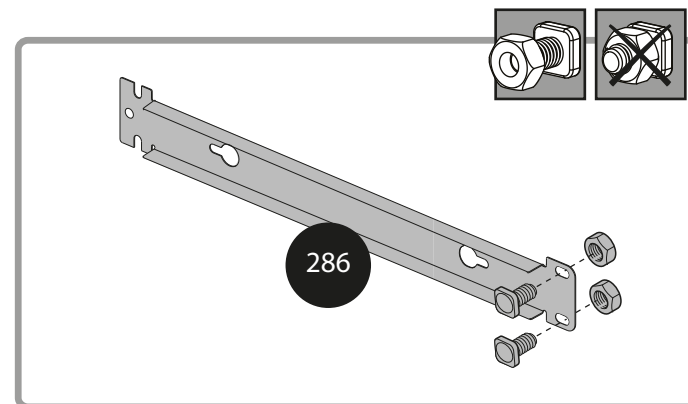
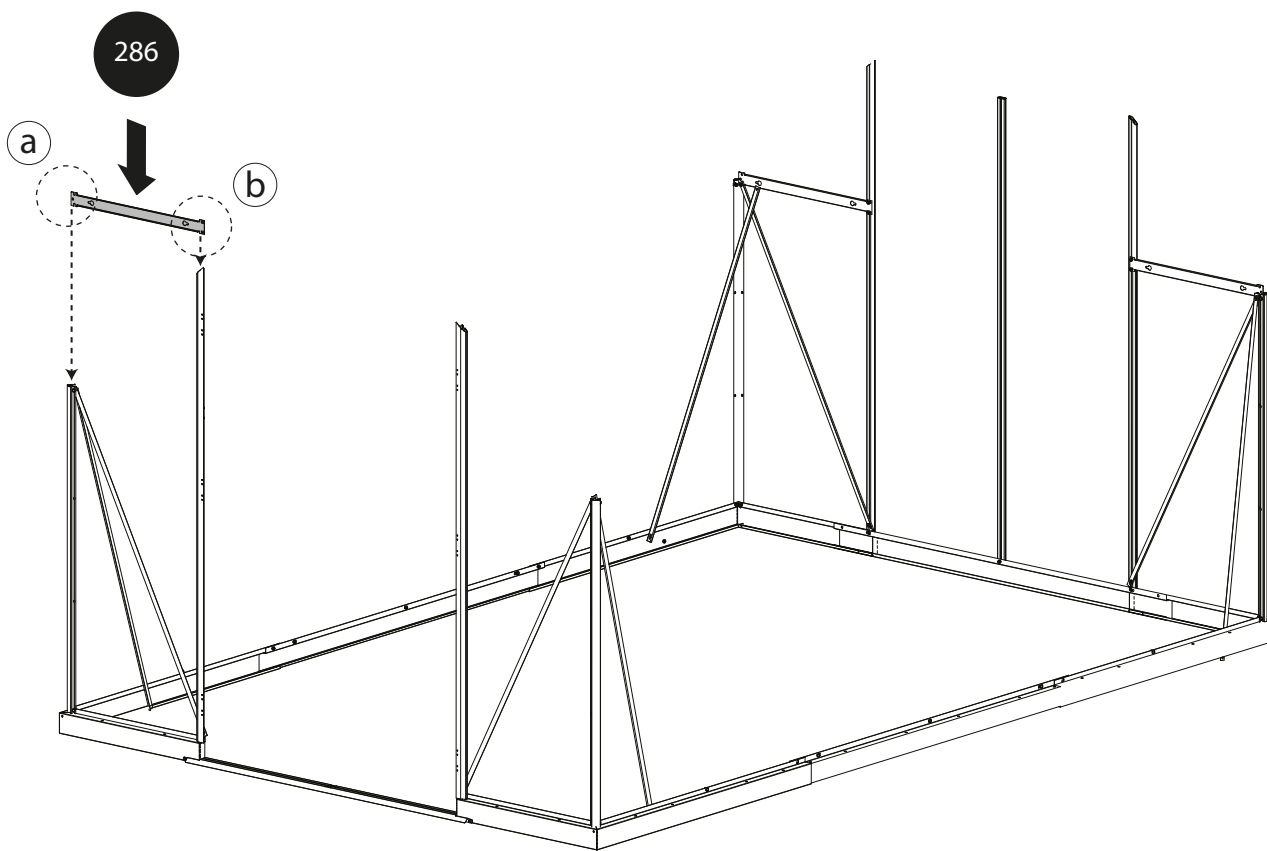

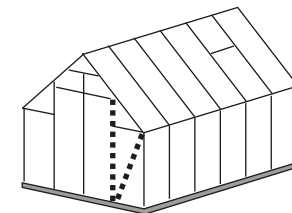

7074



x1

412



x1

411



x1

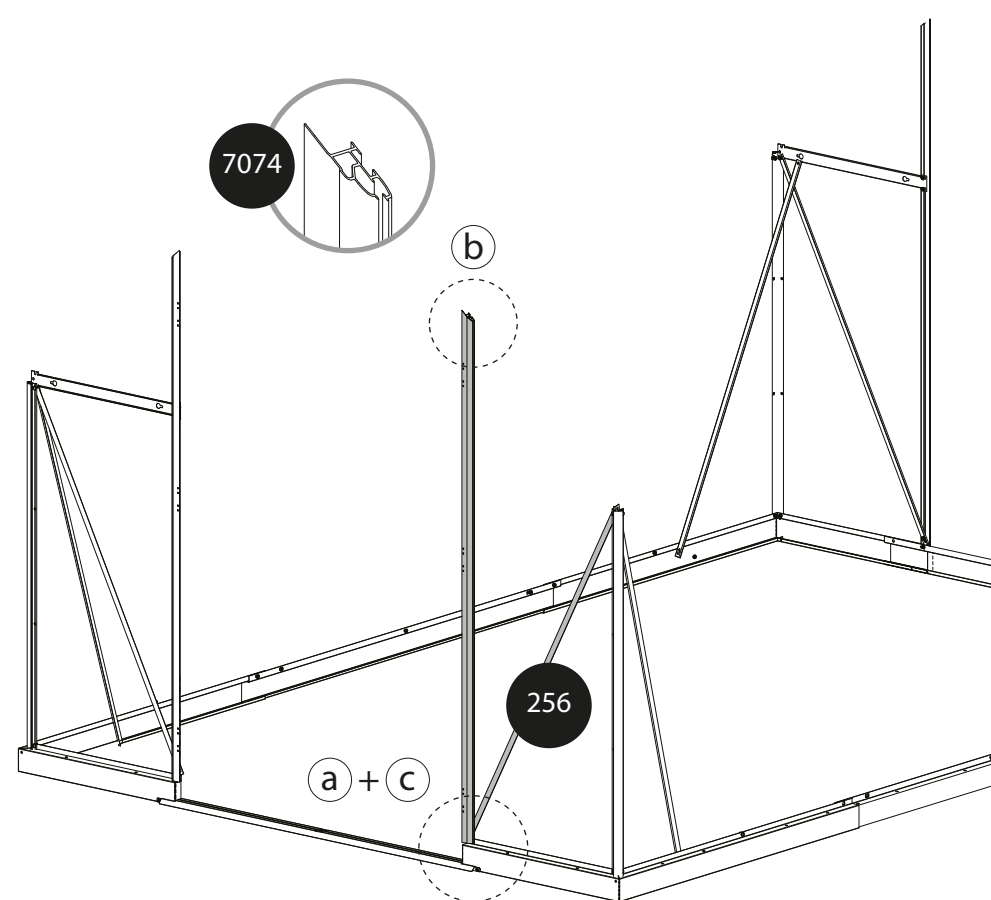
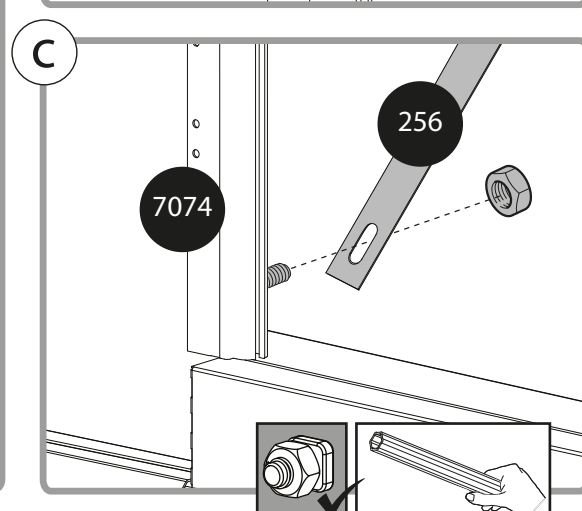
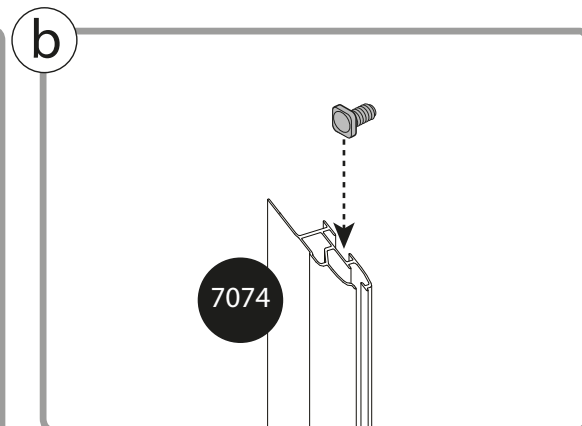
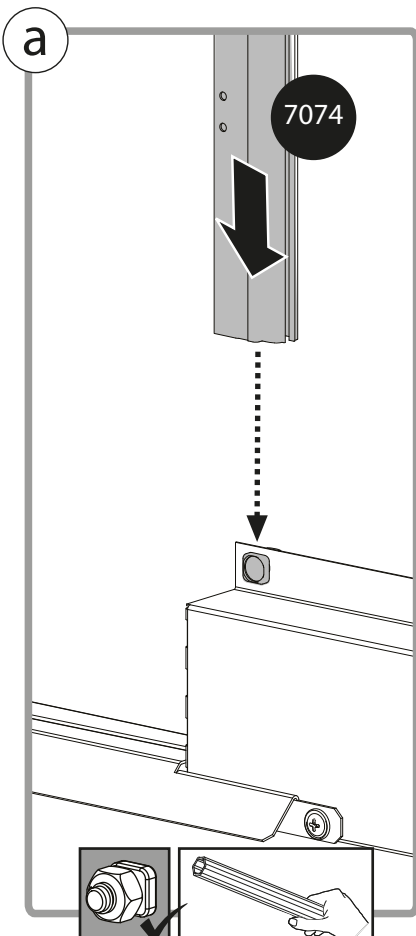

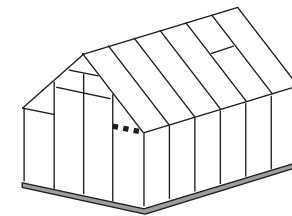

286

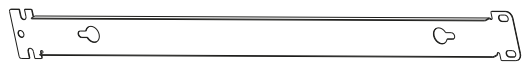

x1

412



x2

411

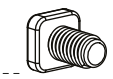

x2

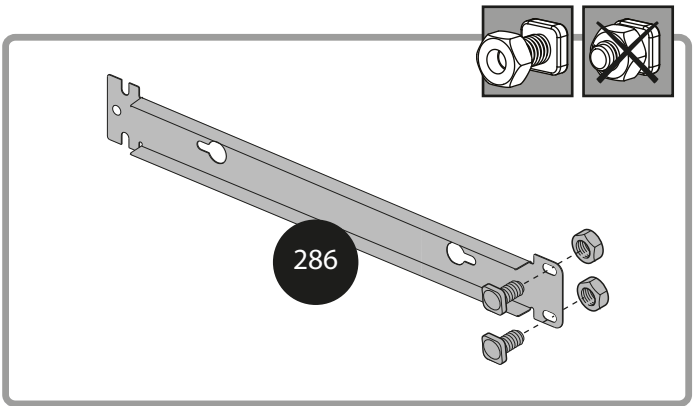

286

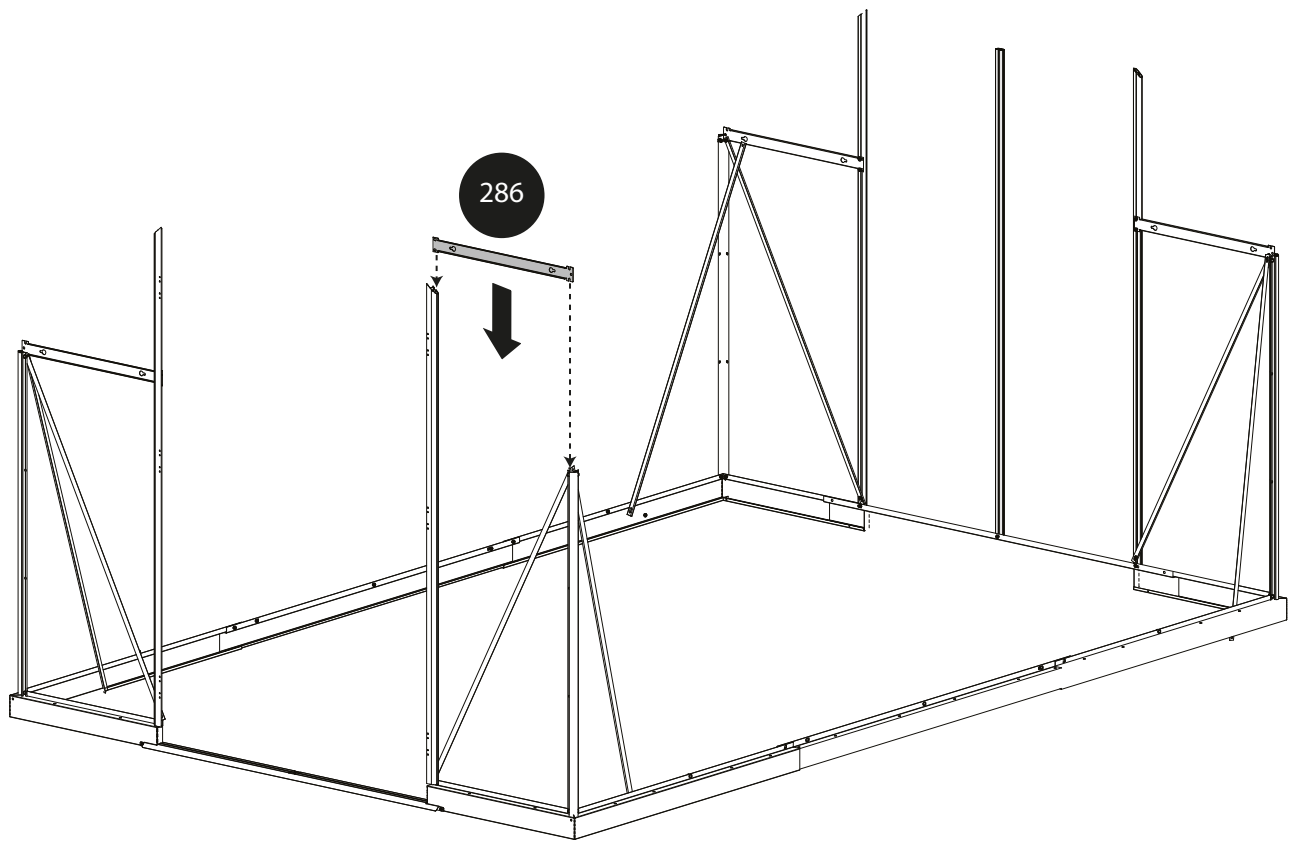

286

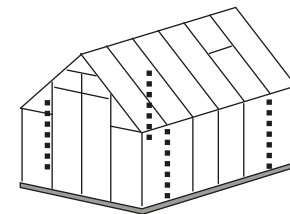

993

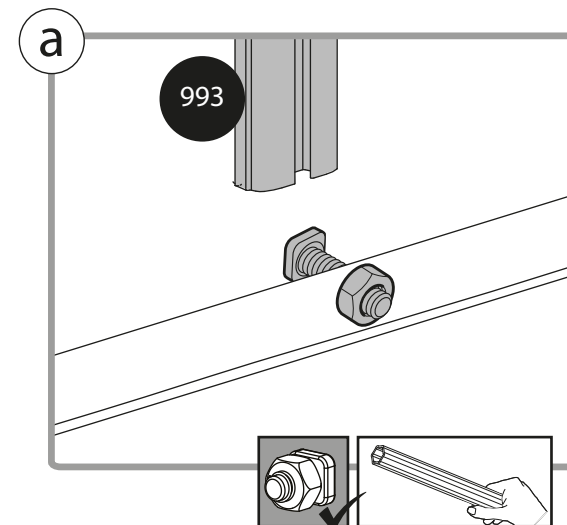
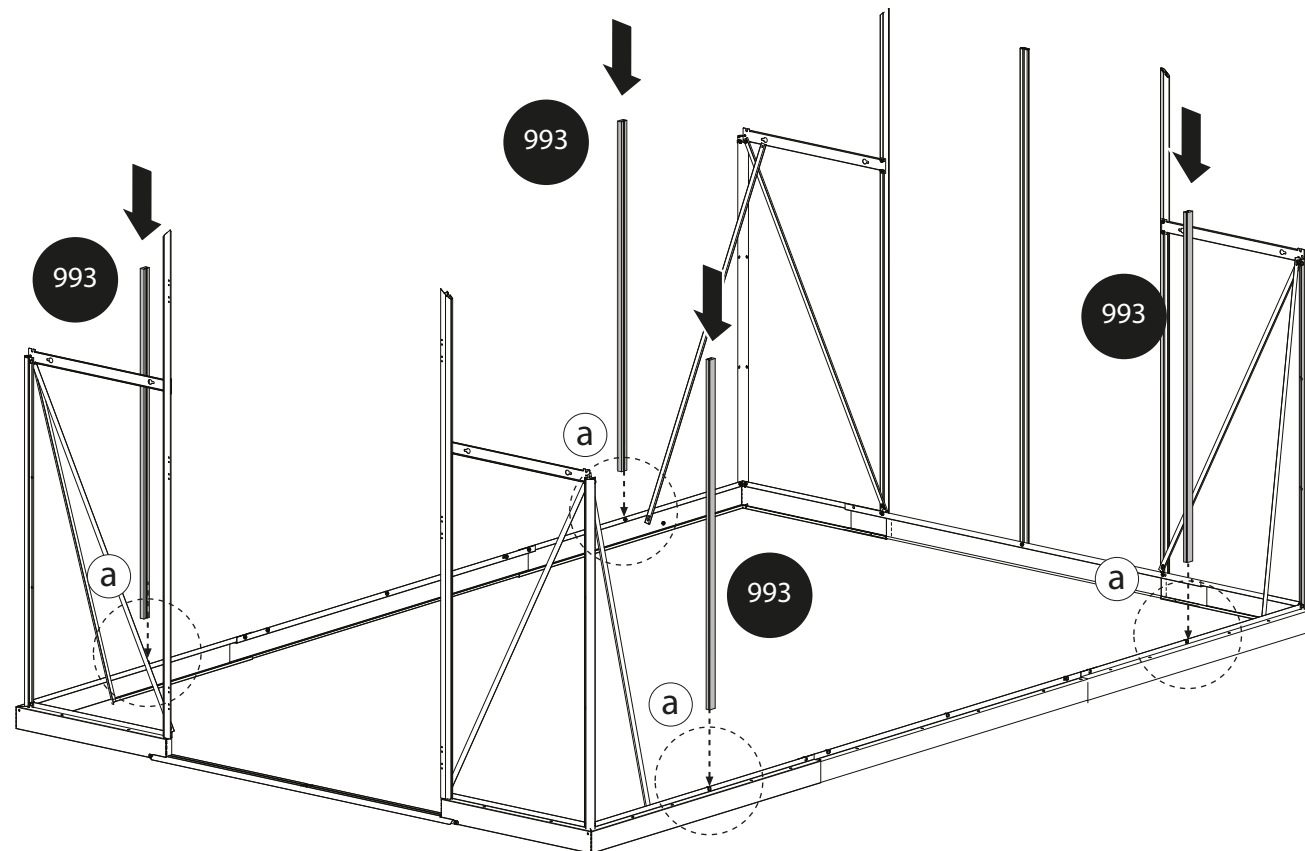
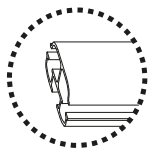

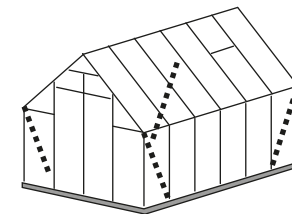

412



x4

411



x4

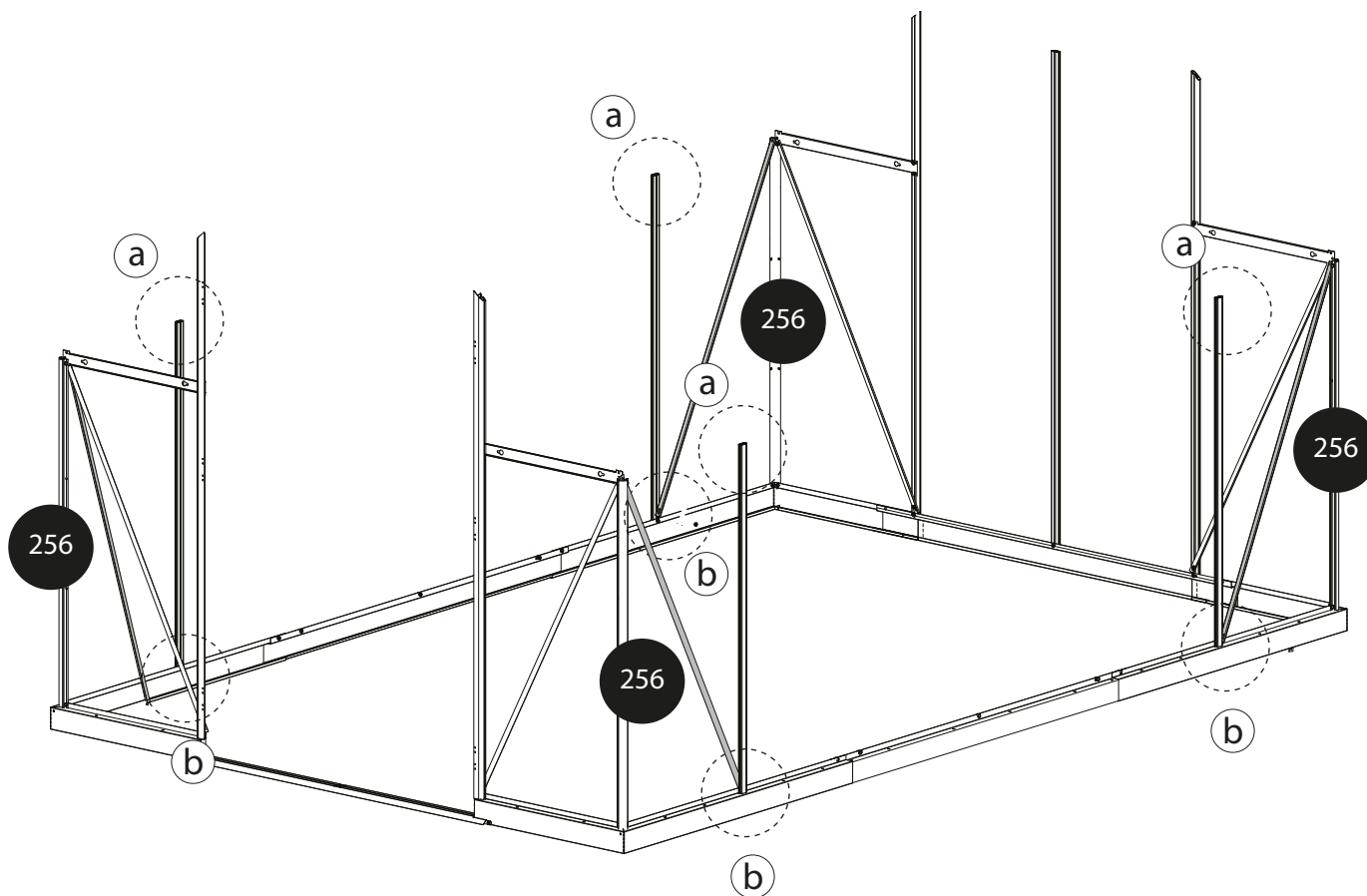

a

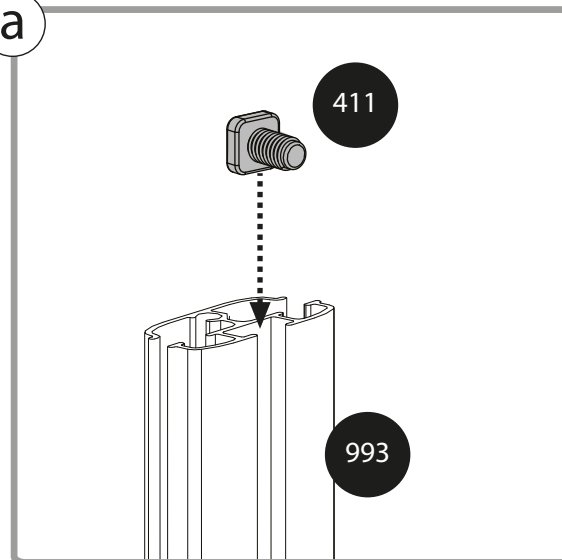

b

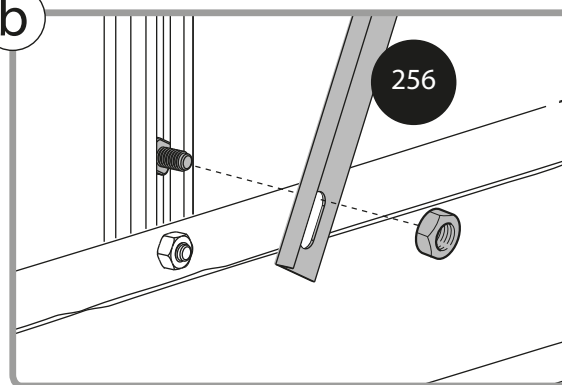

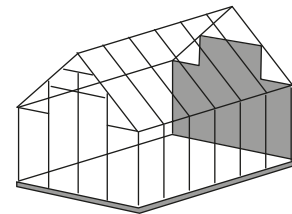

7011

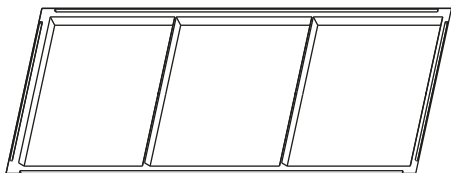

x2

7077

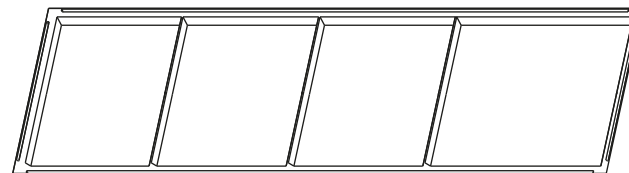

x2

7077

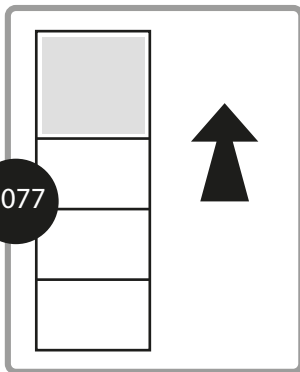

7077

7077

7011

7011

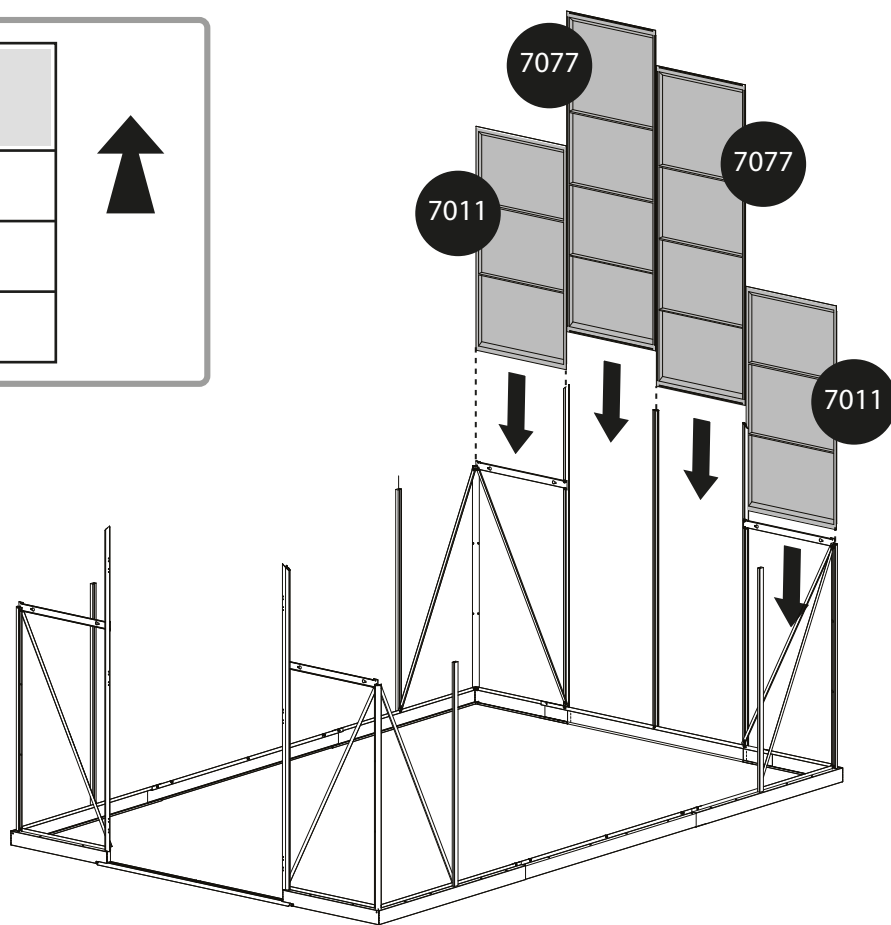

7077

/

7011

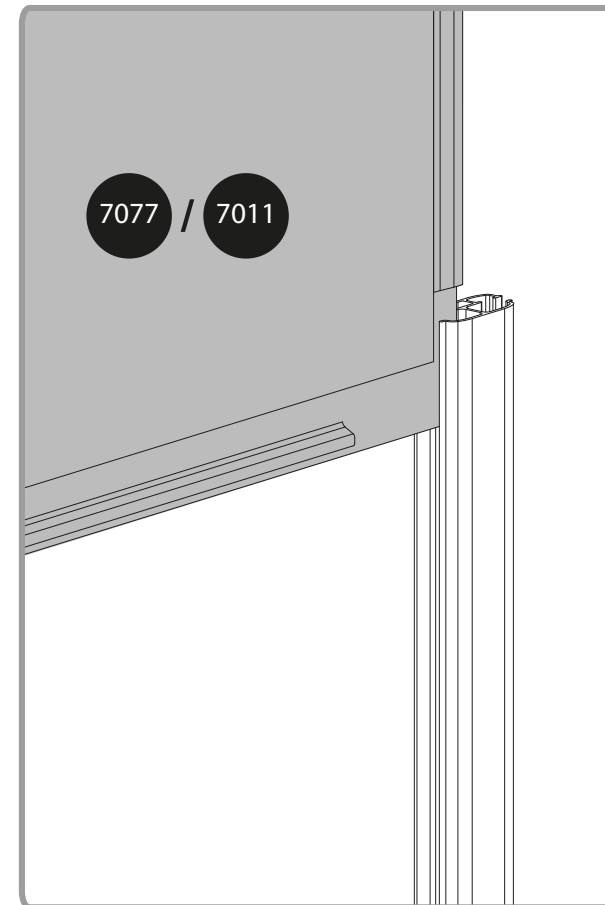

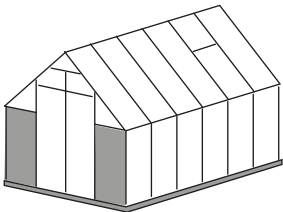

7011

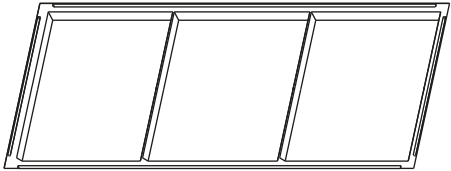

x2

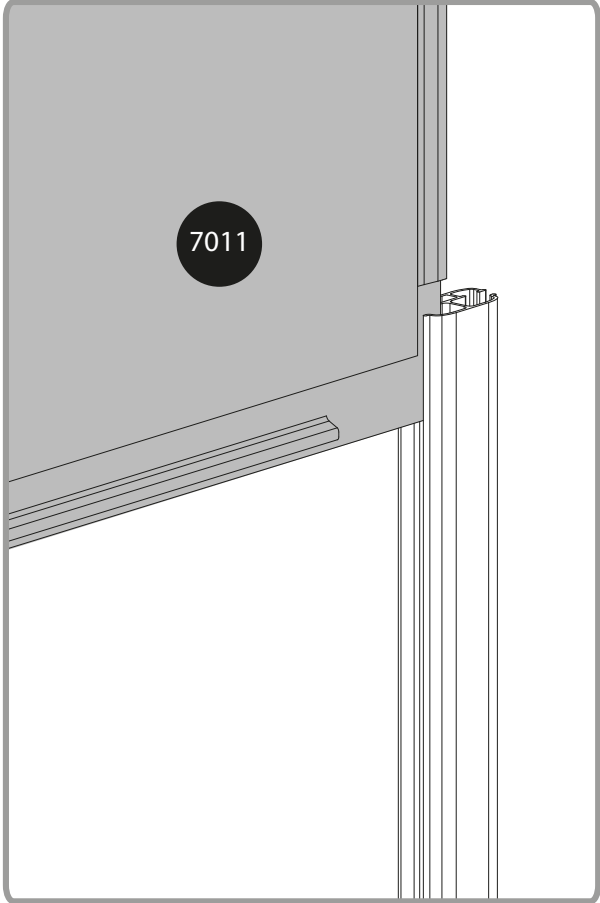
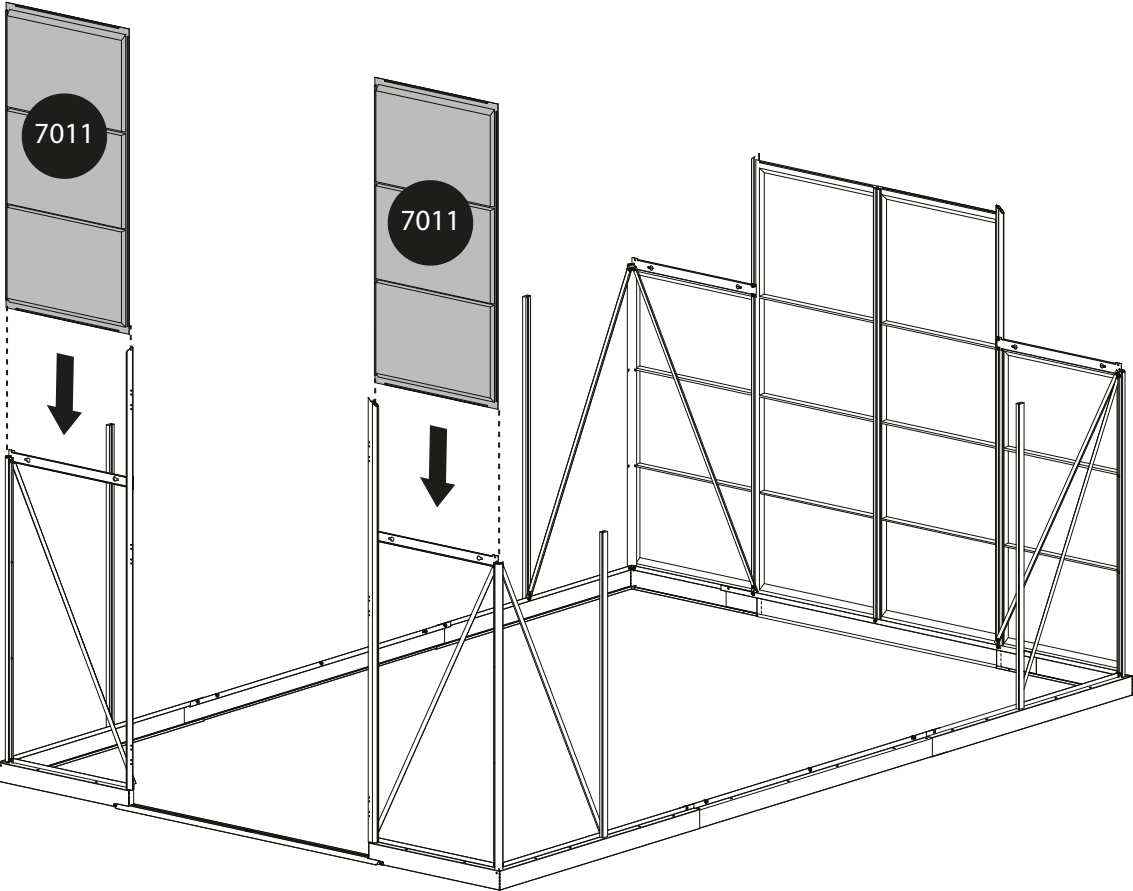

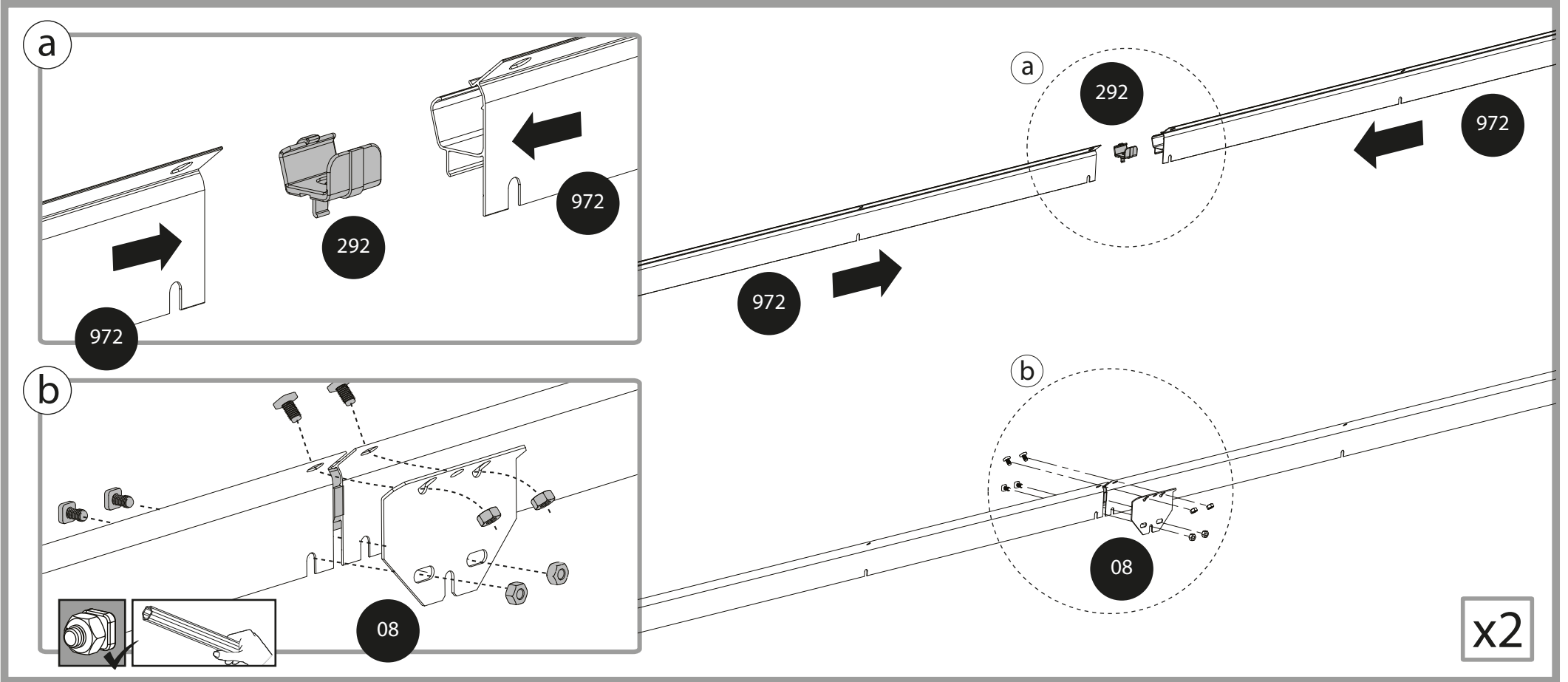
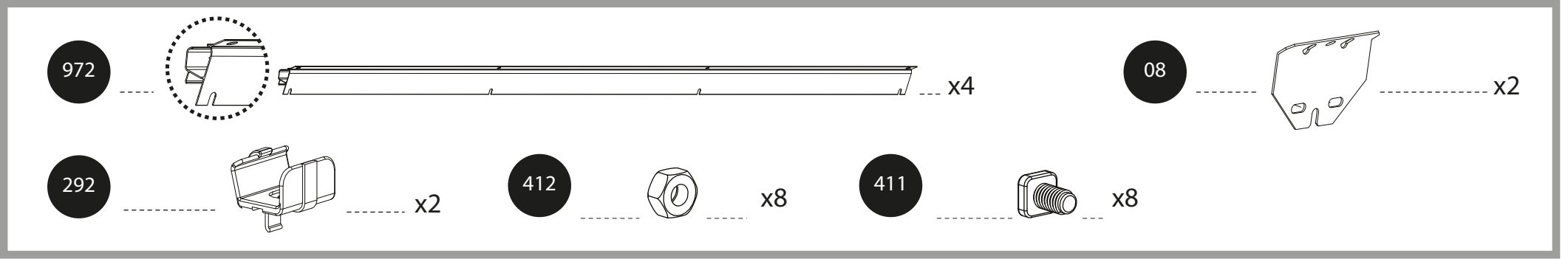
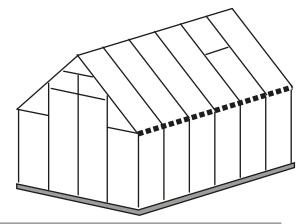

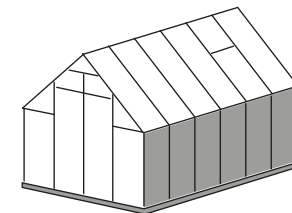

7011

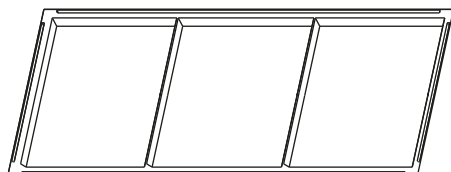

x6

993

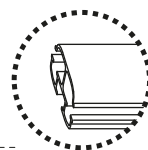

x3

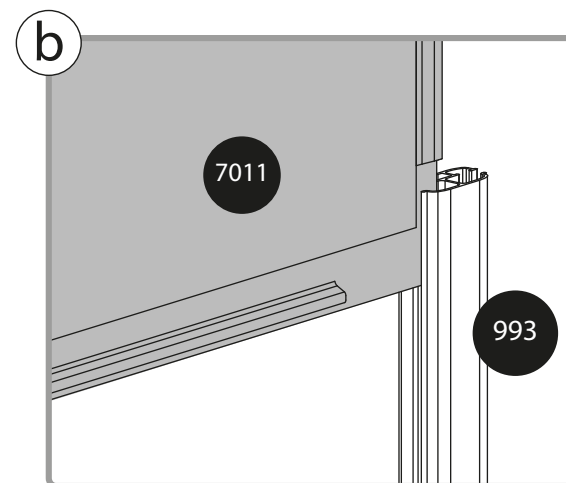
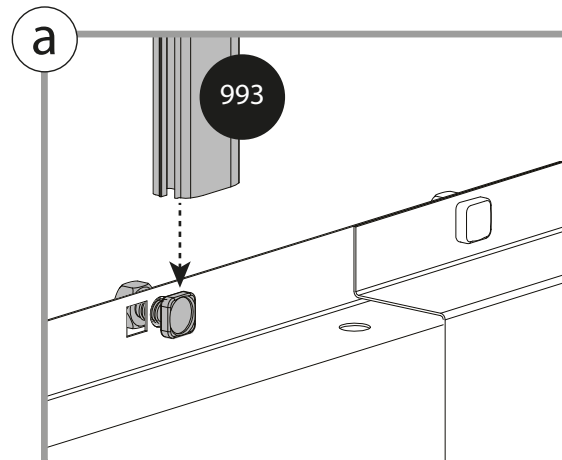
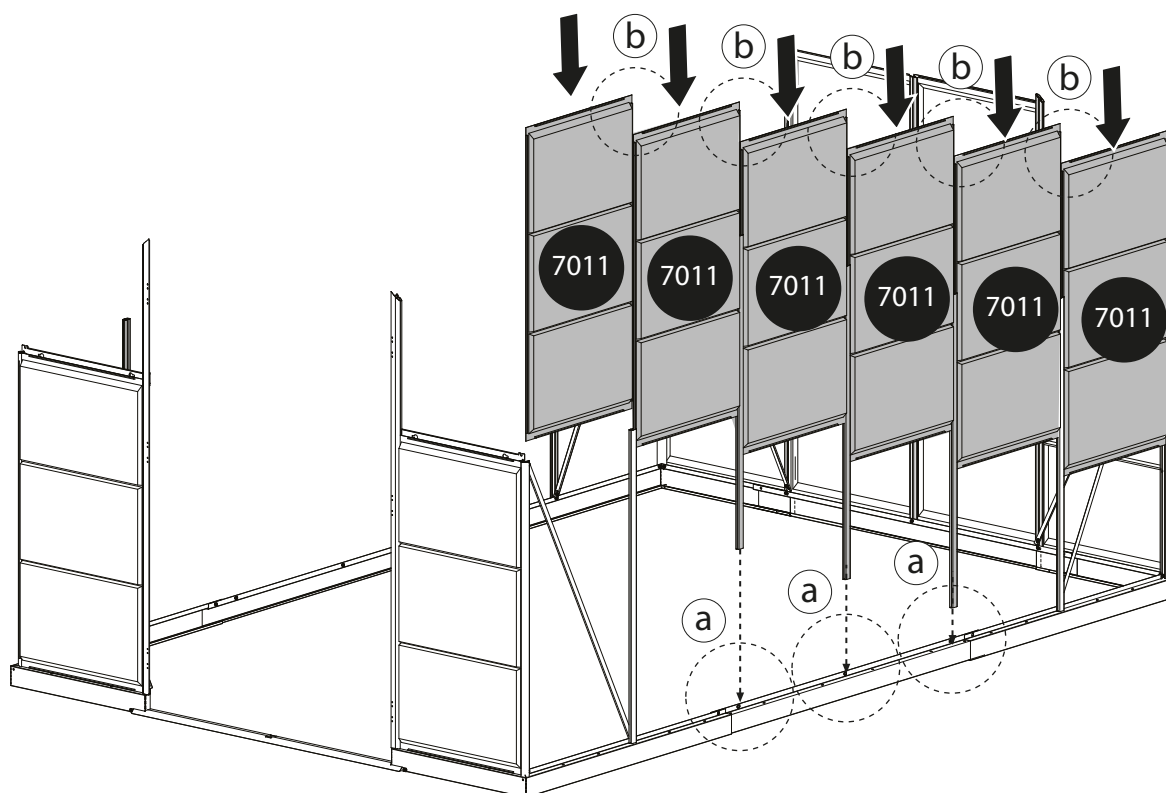

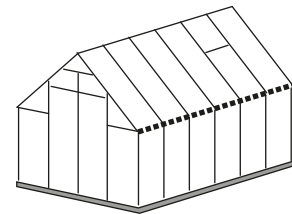

318
PVC

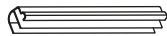

x6

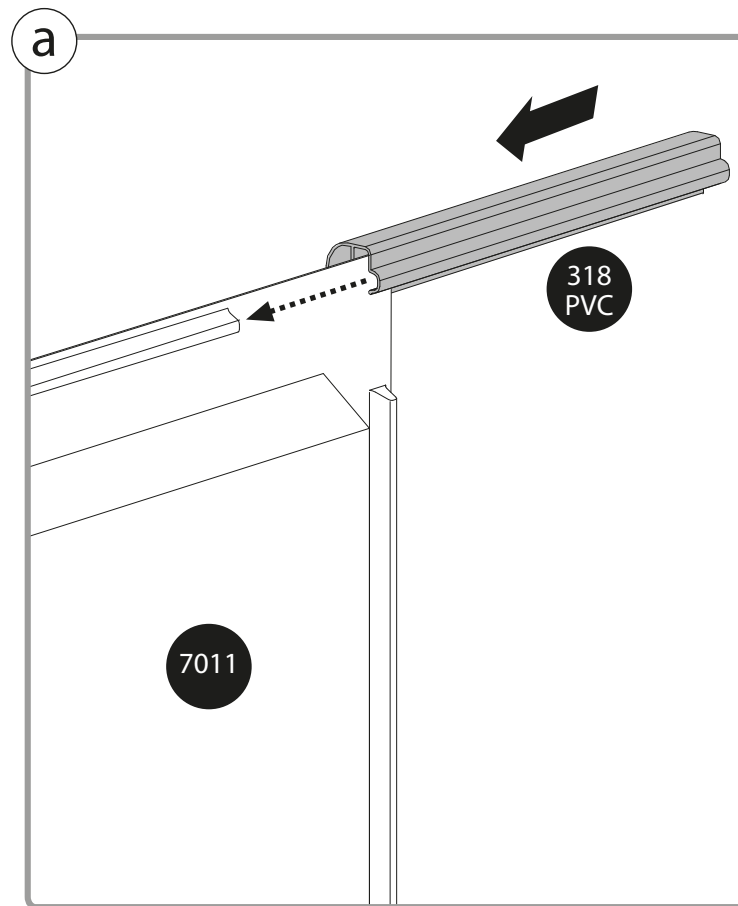
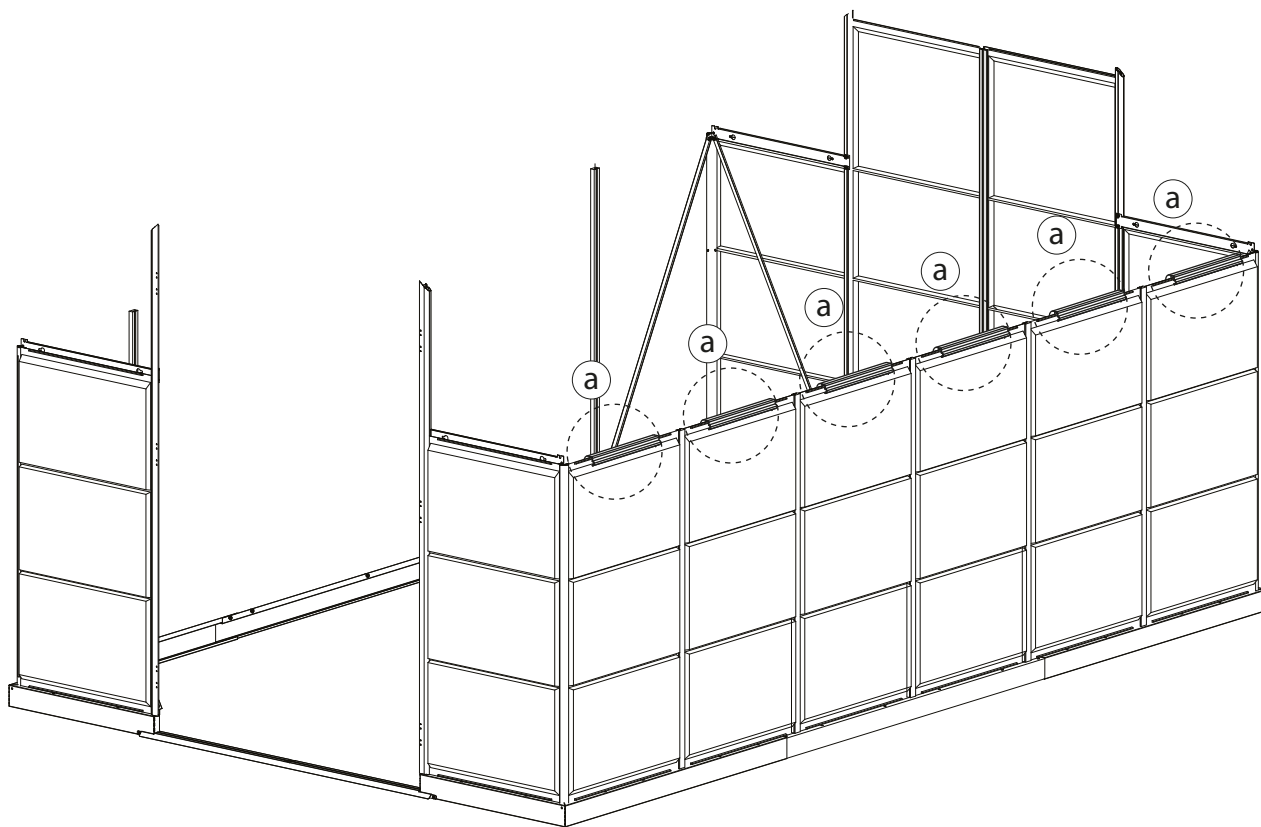

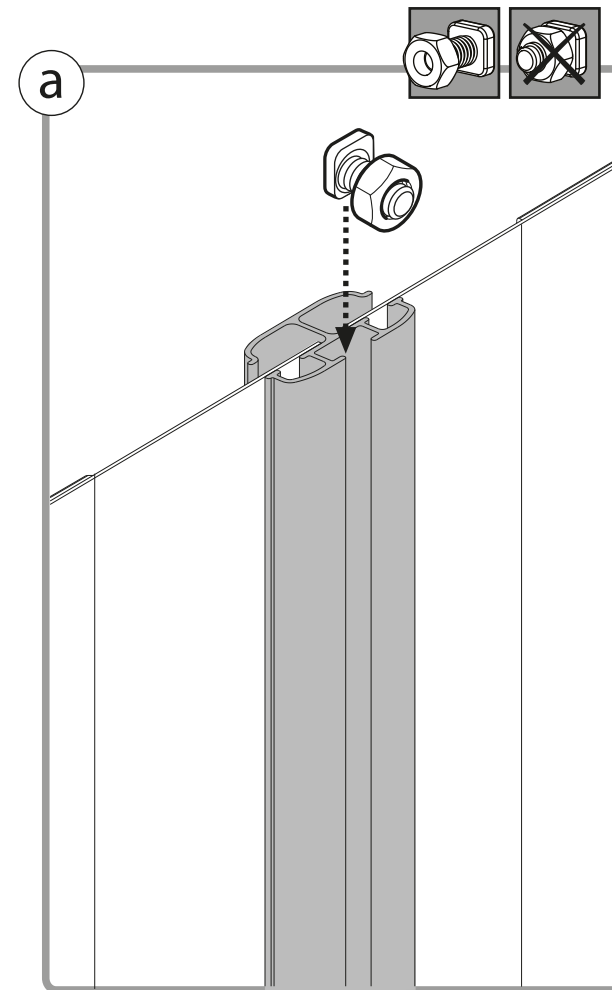
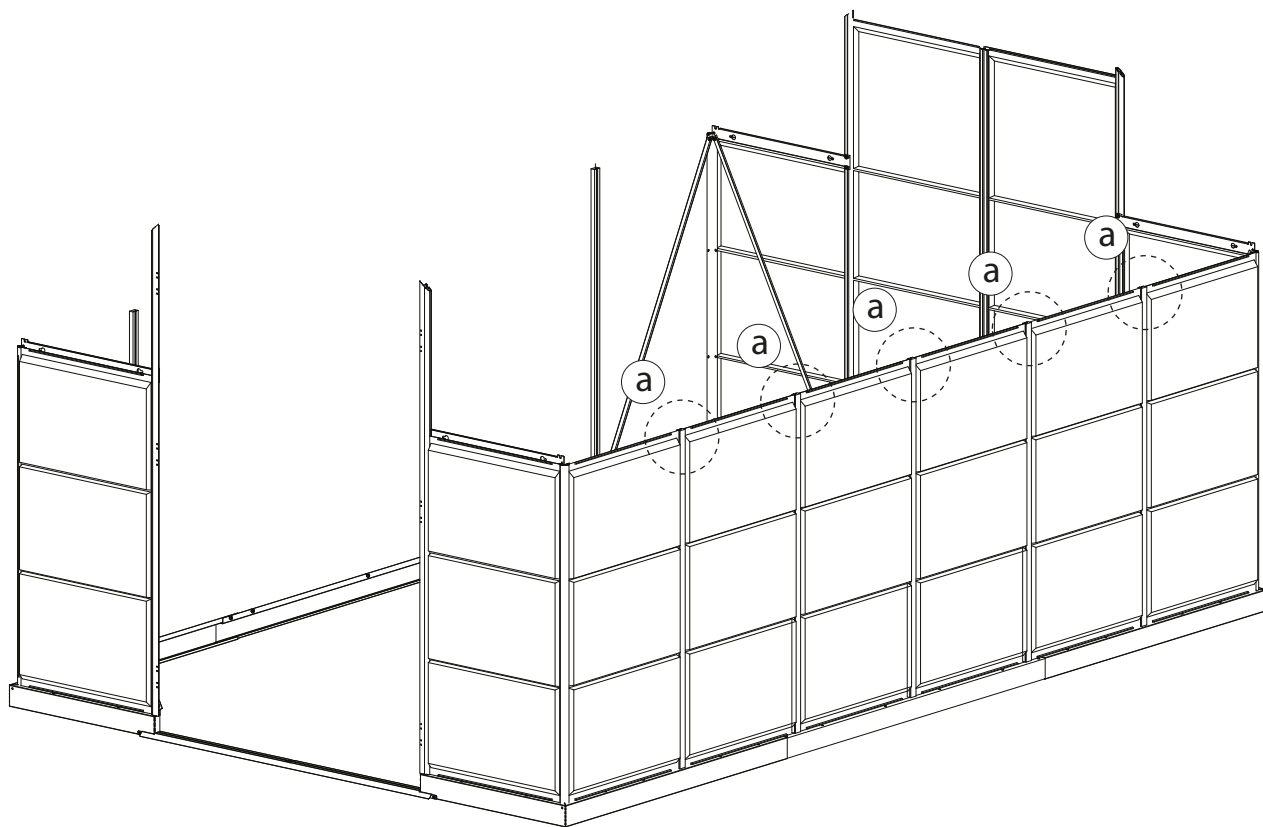
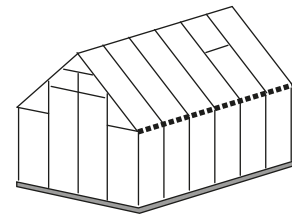

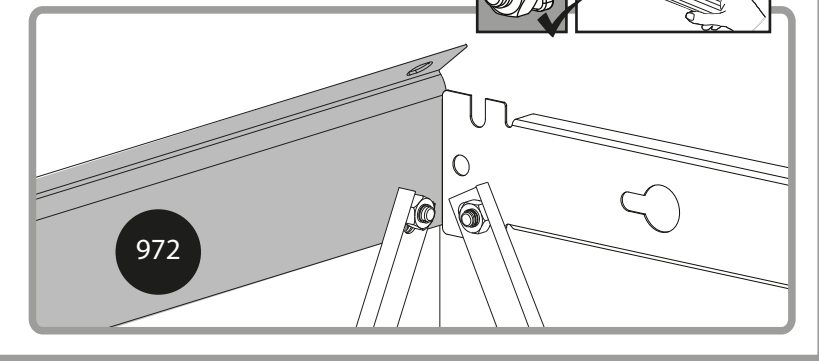
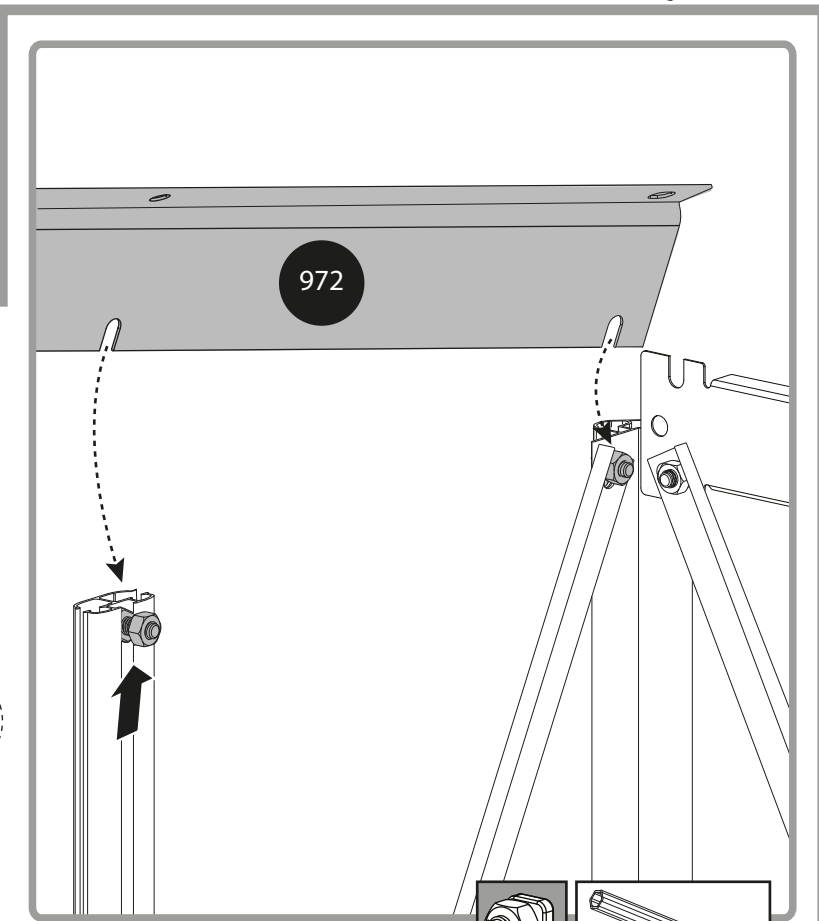
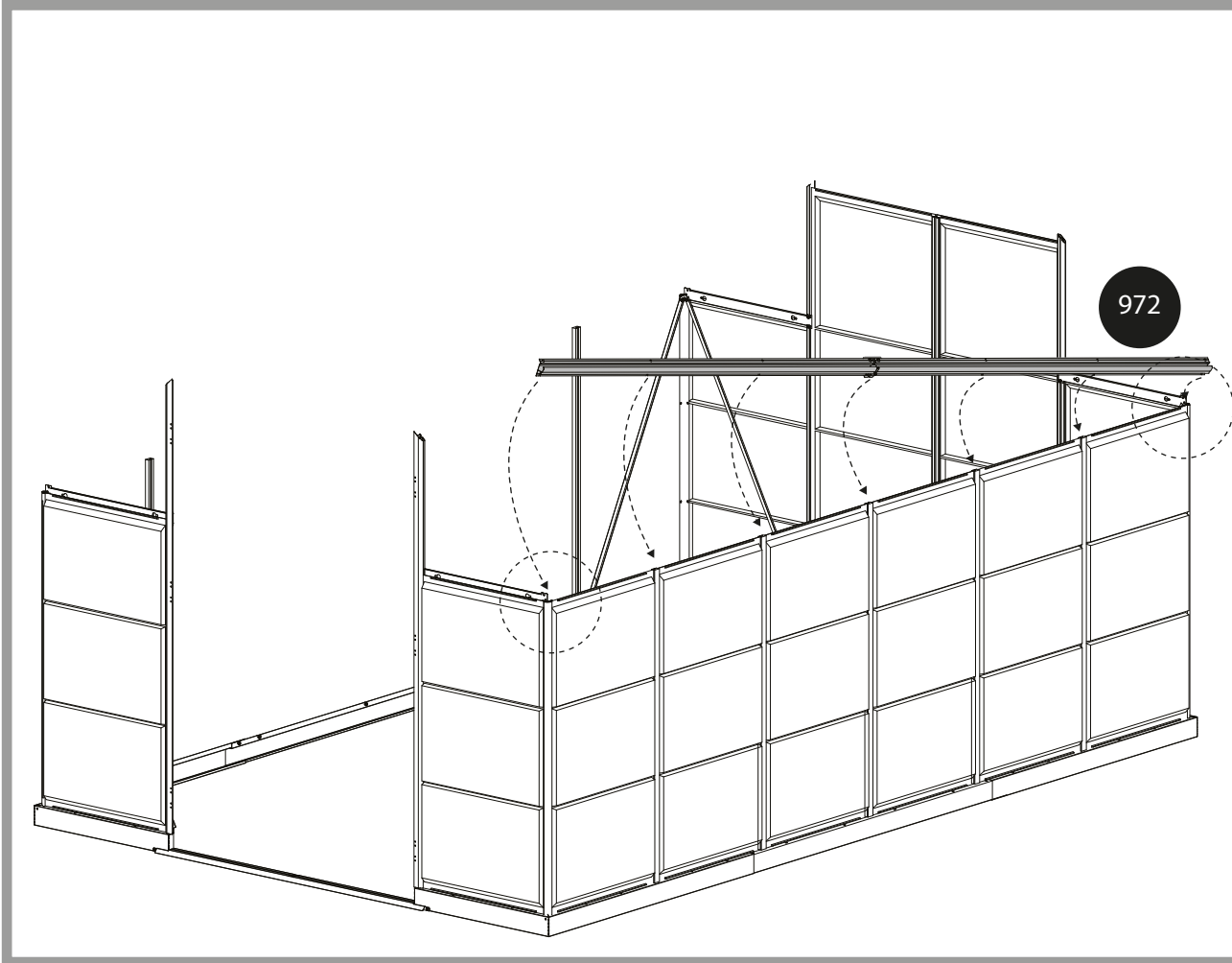
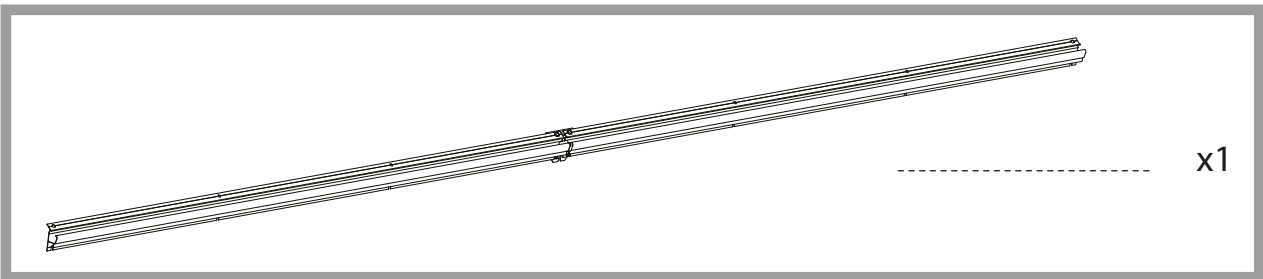
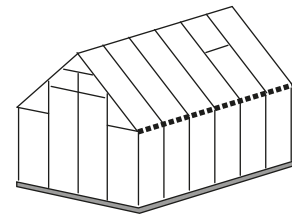

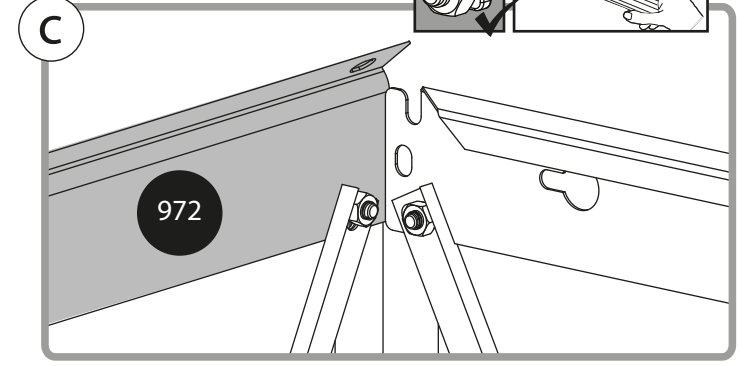
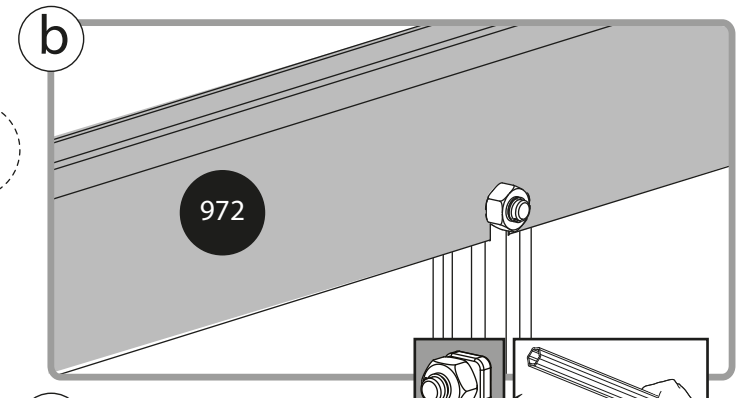
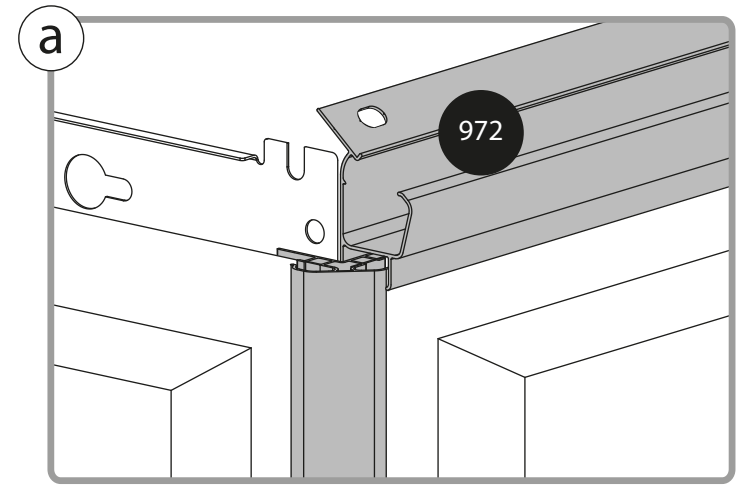
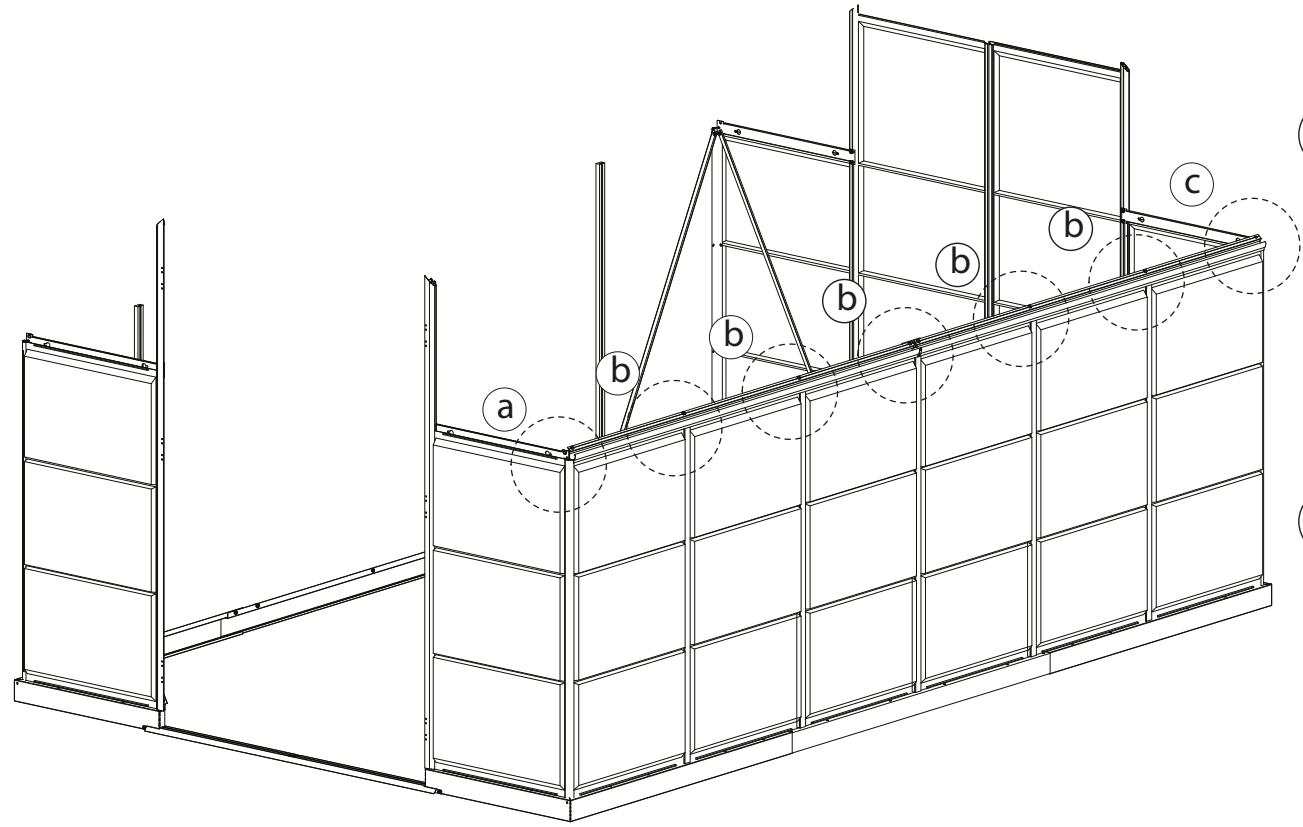
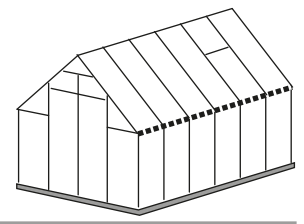

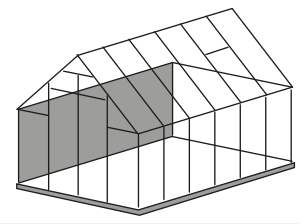

7011

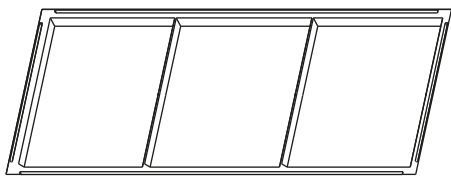

x6

993

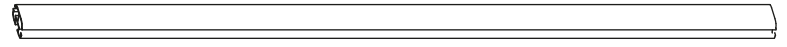
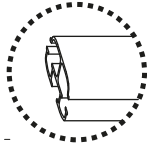

x3

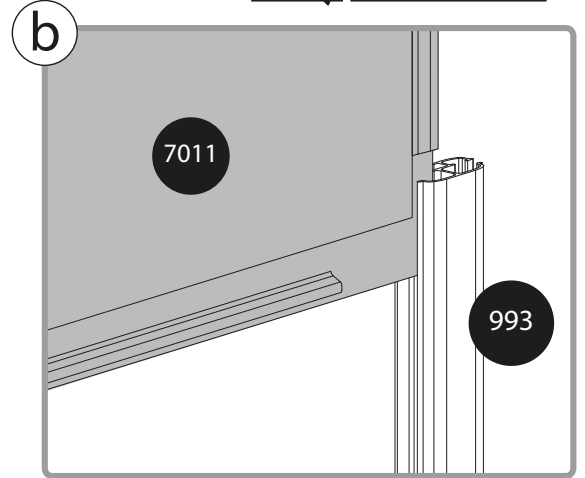
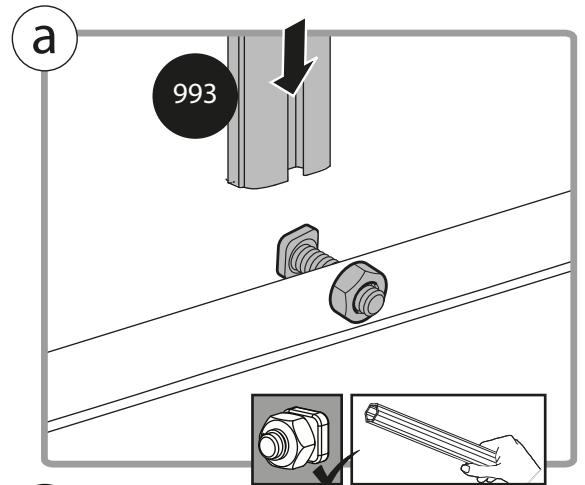
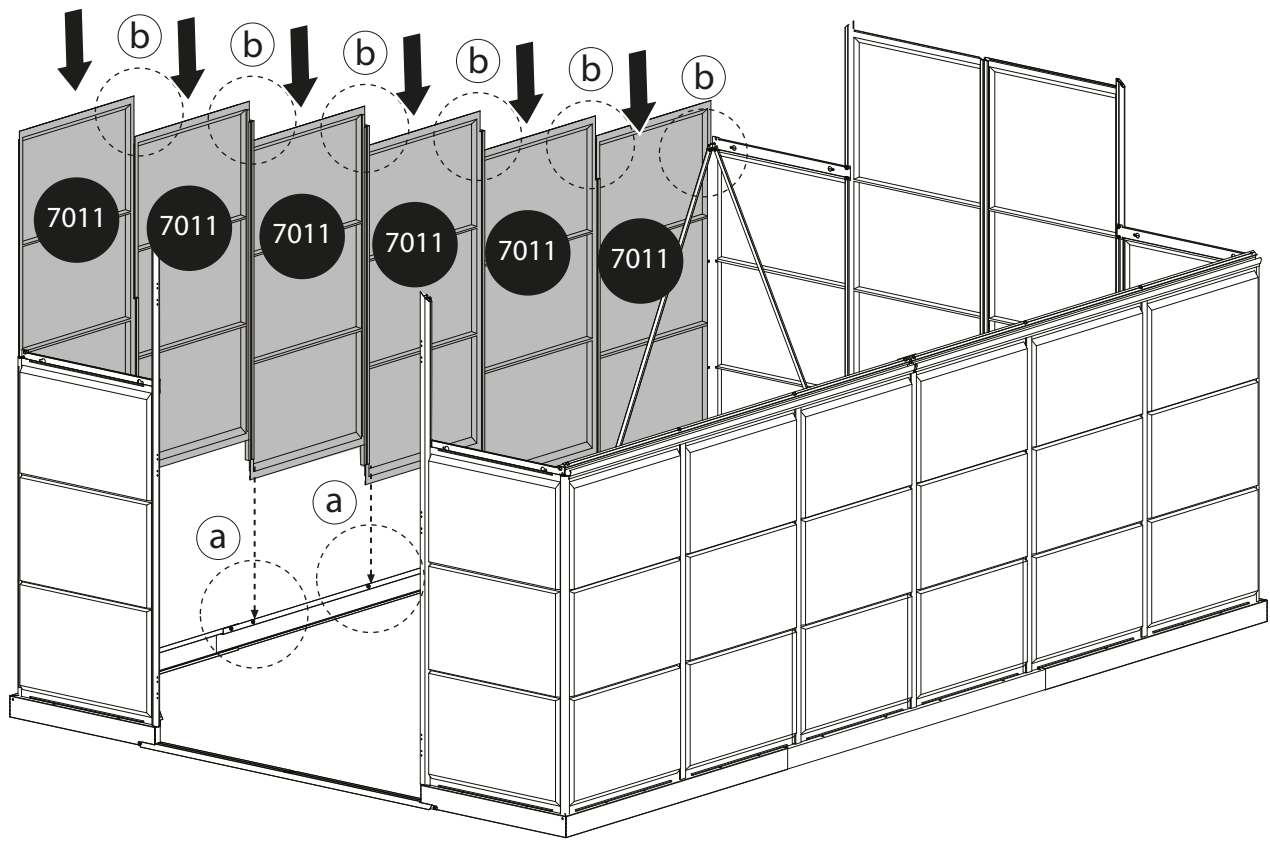

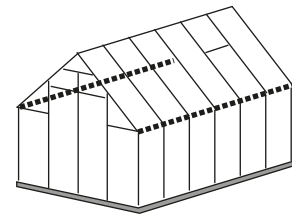

318
PVC



x6

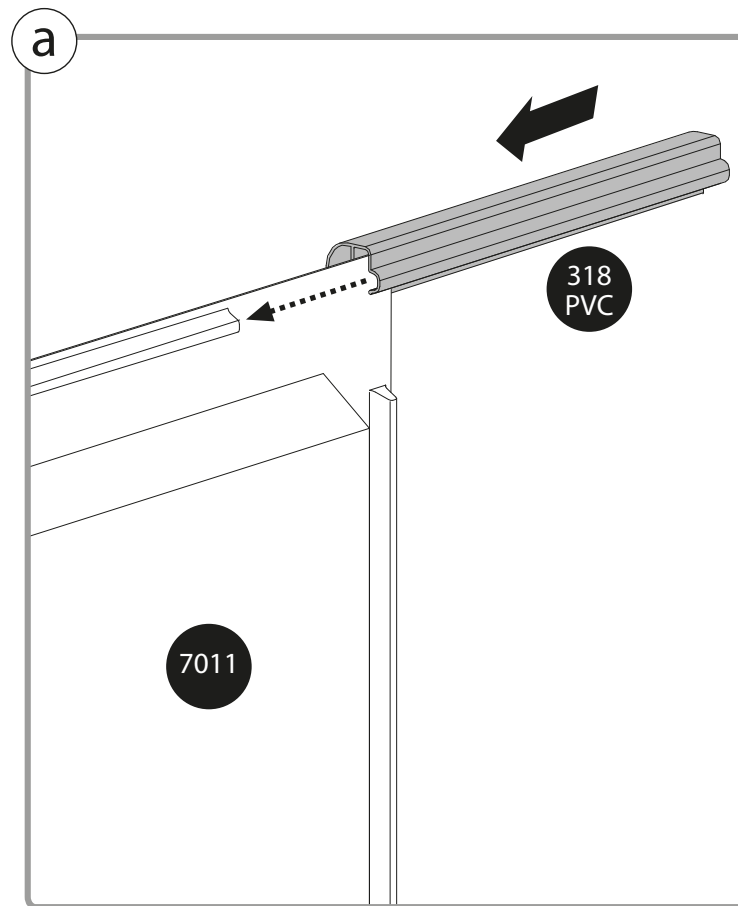
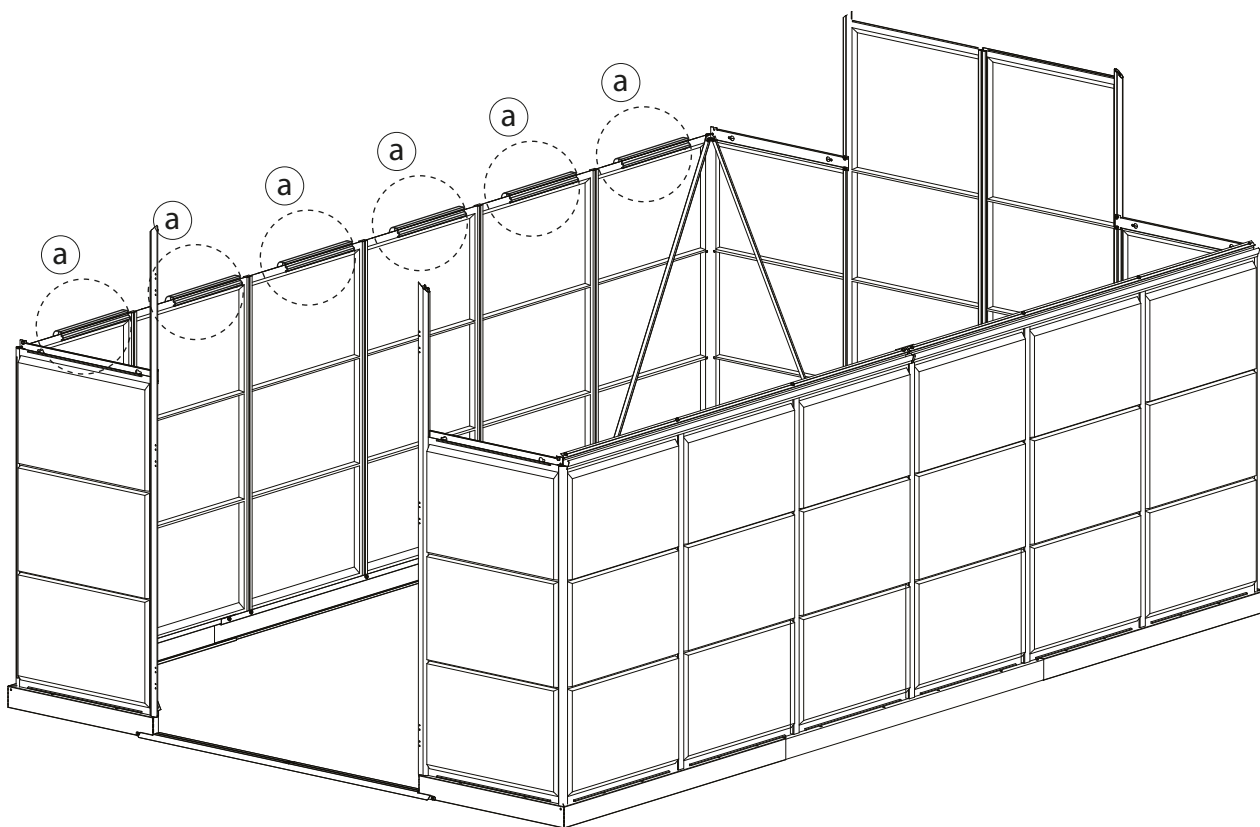

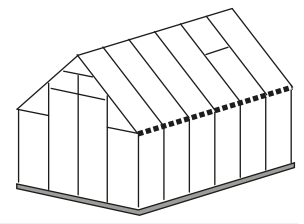

412



x5

411

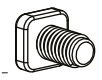

x5

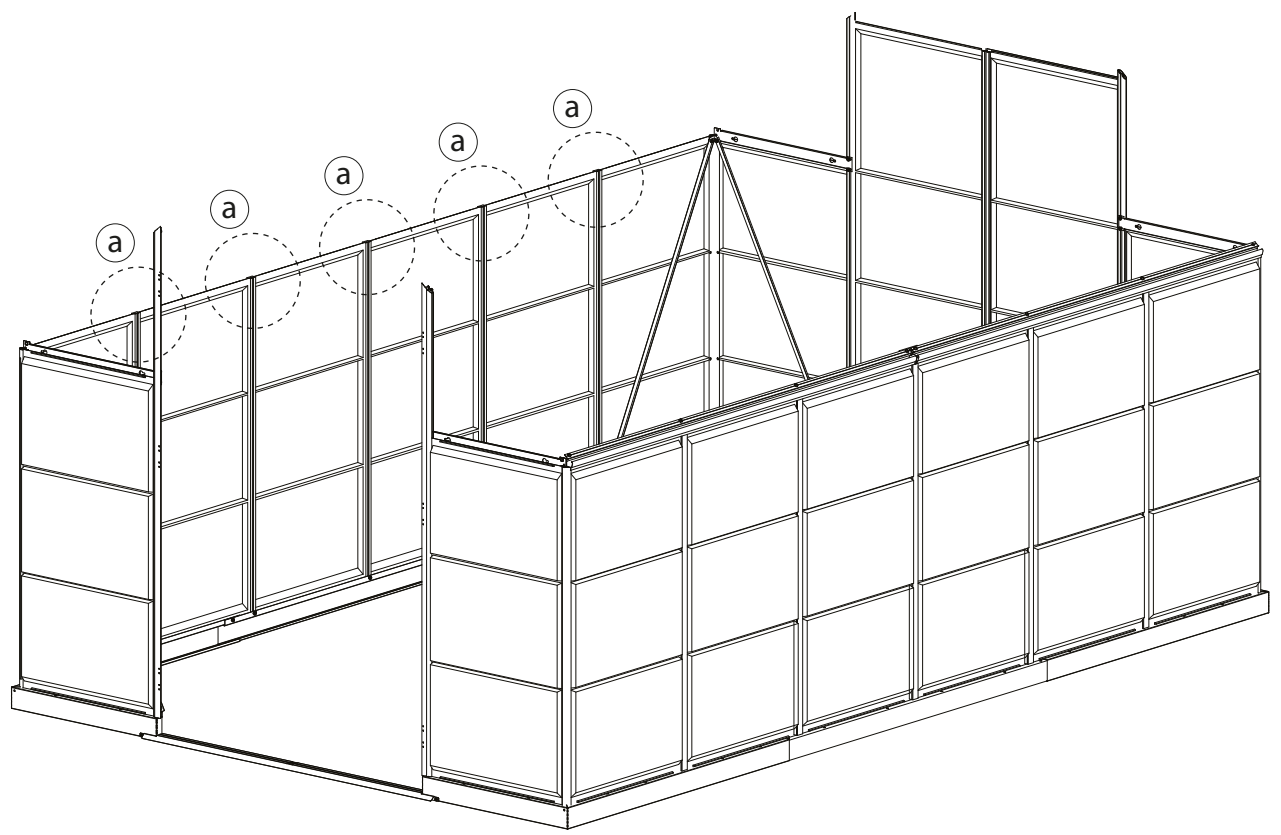

a

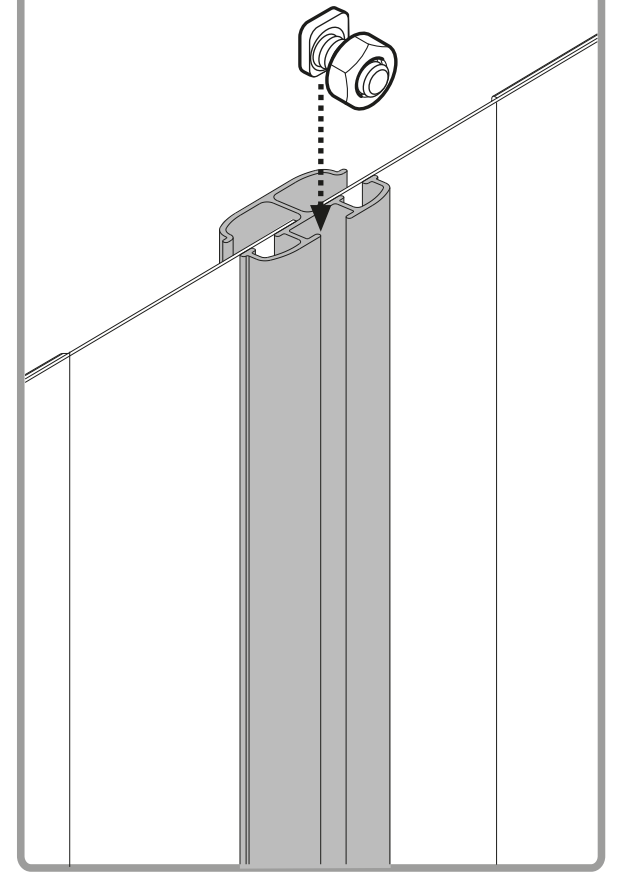
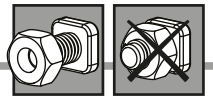

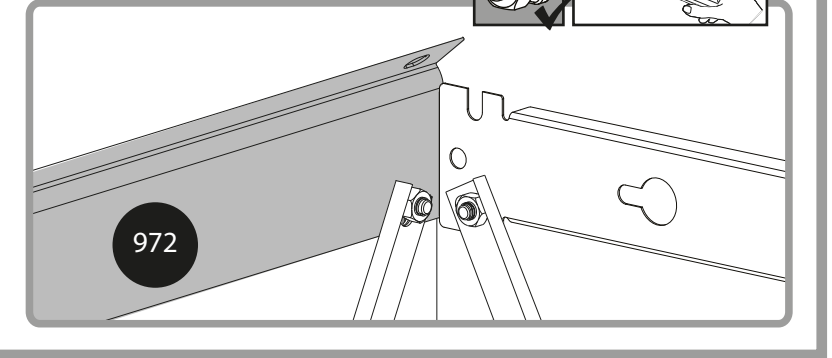
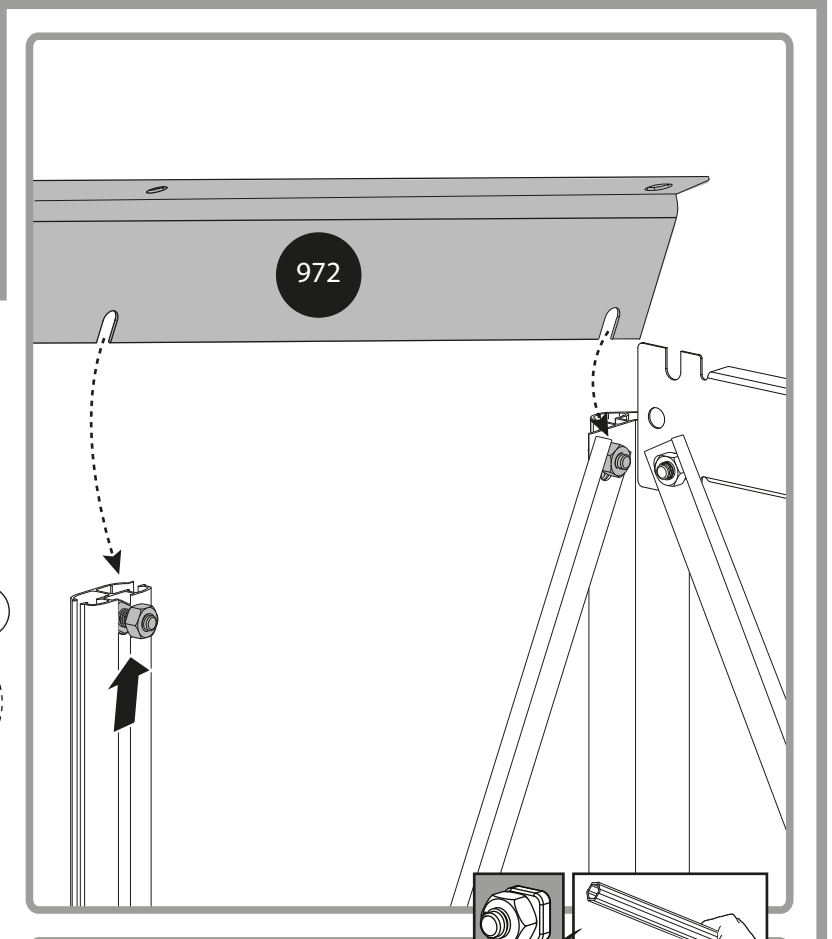
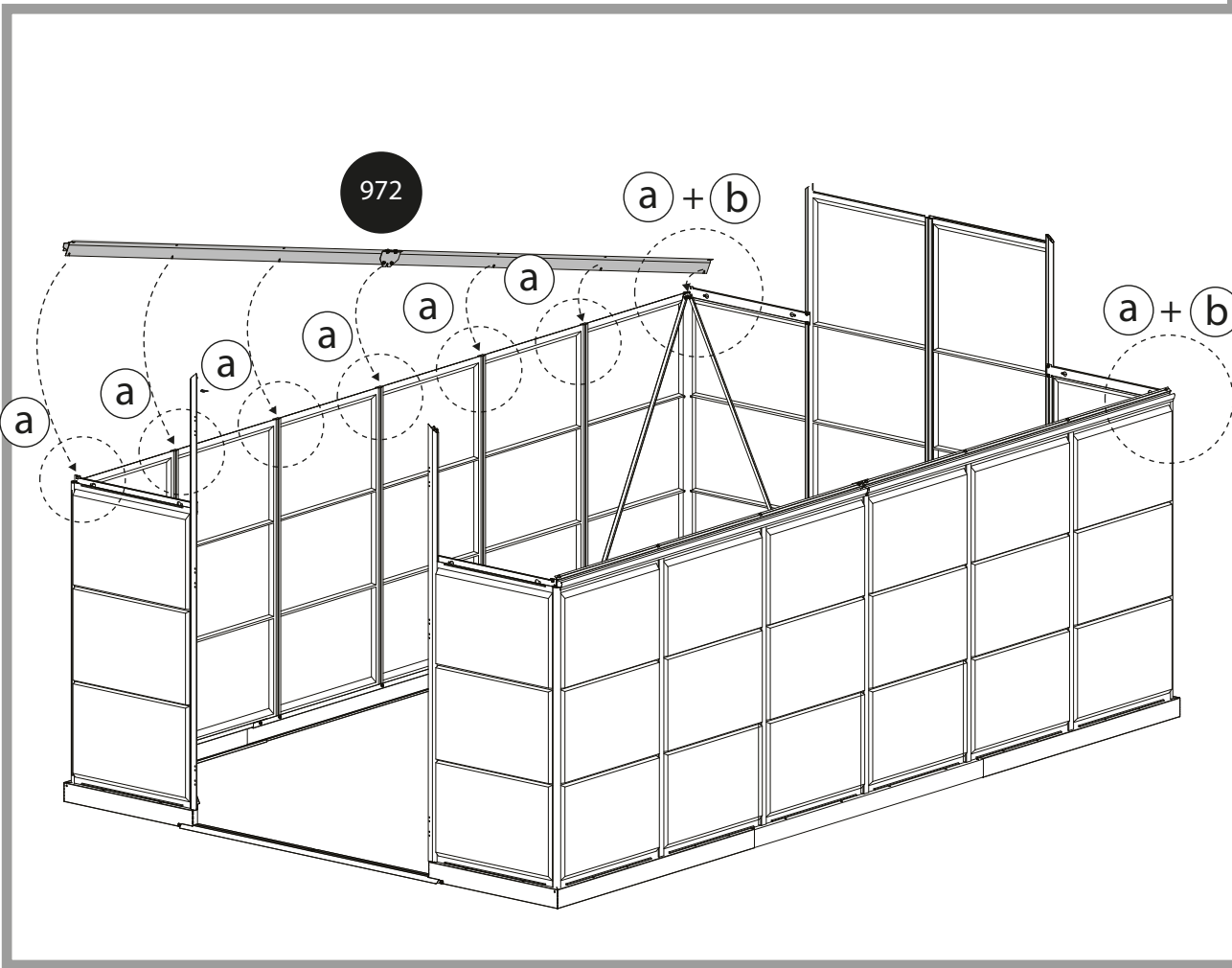
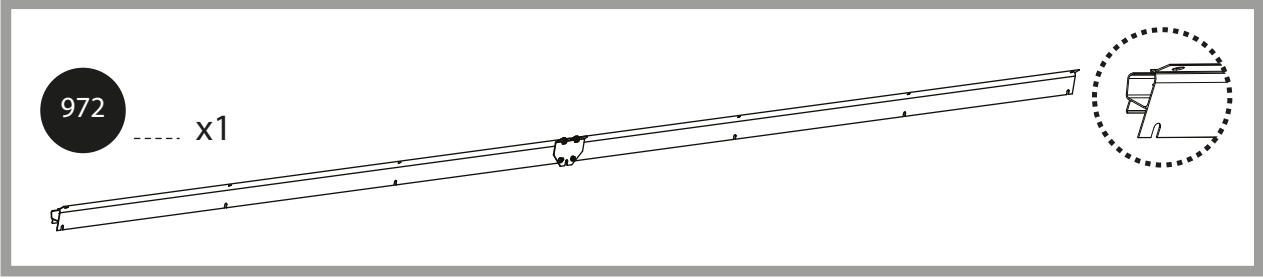
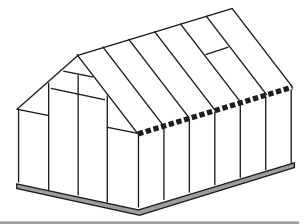

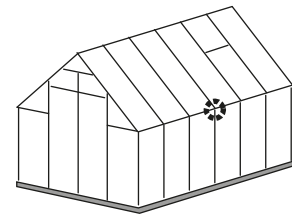

4008



x2

412



x1

411



x1

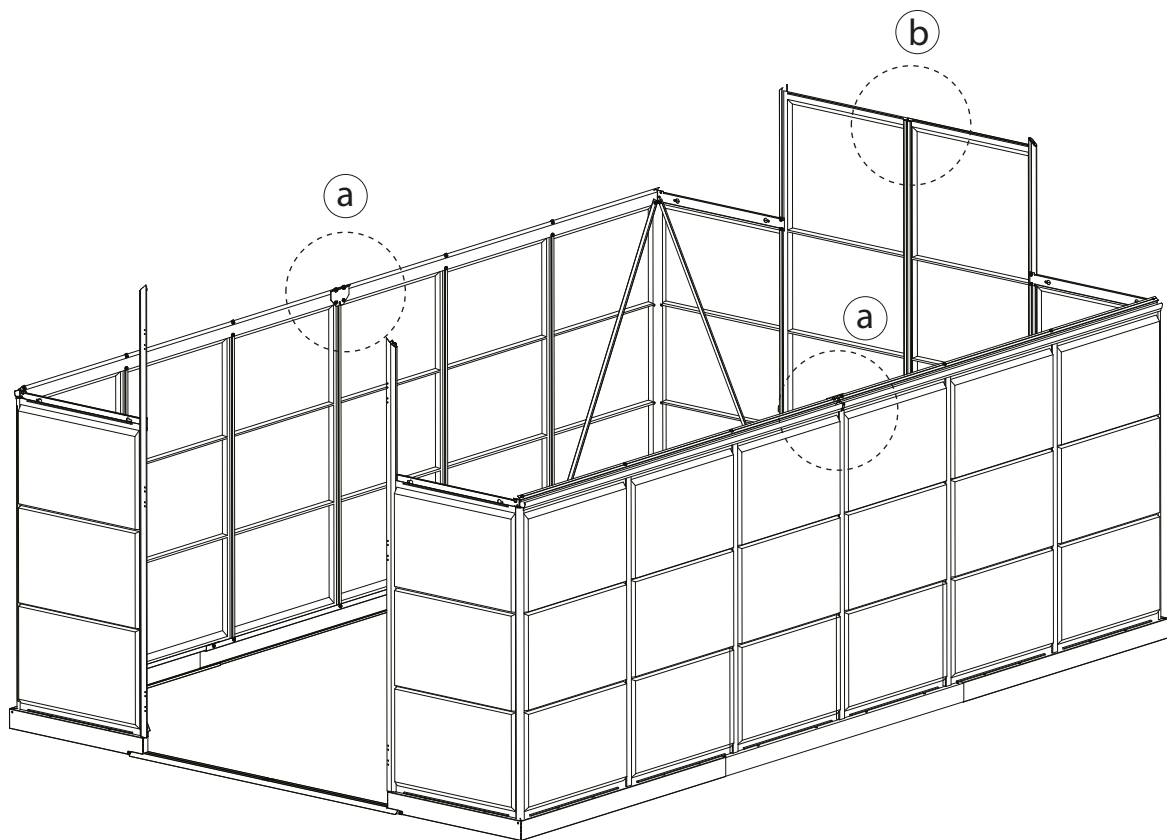

a

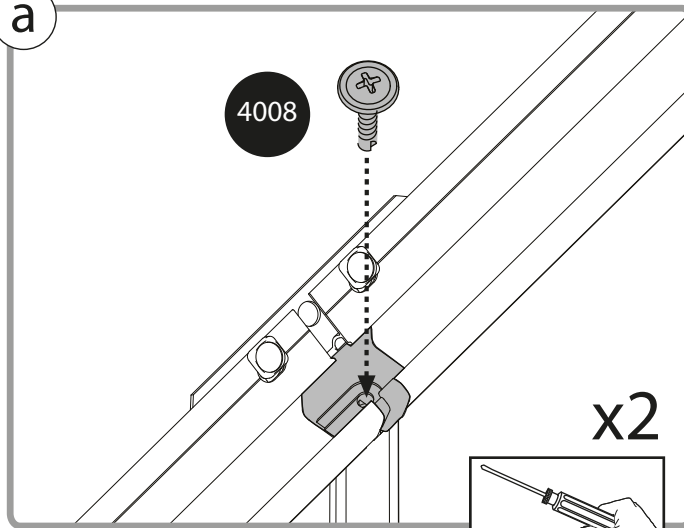

4008

x2

b

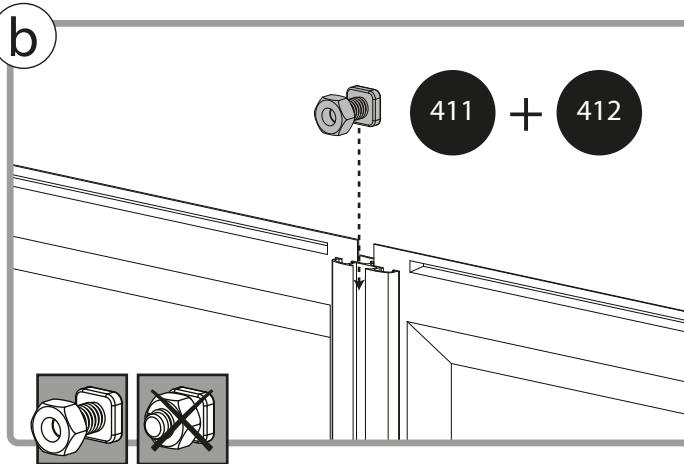

411

+

412

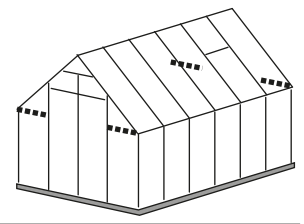

7072

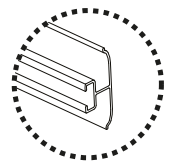
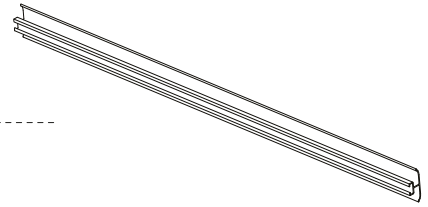

x4

412



x8

411

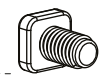

x8

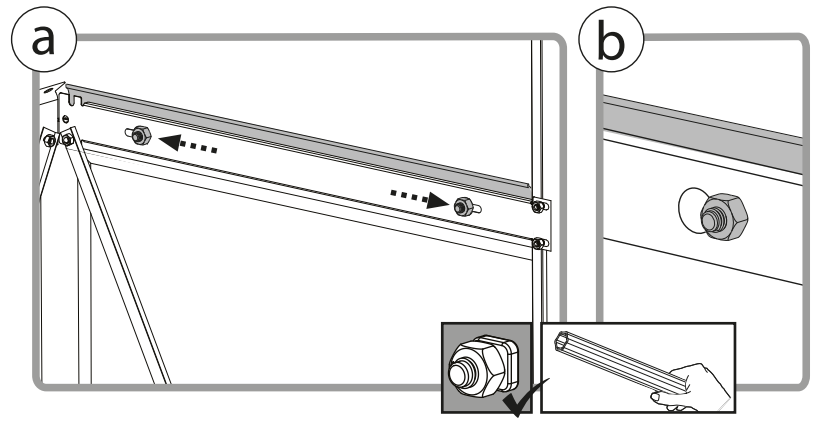
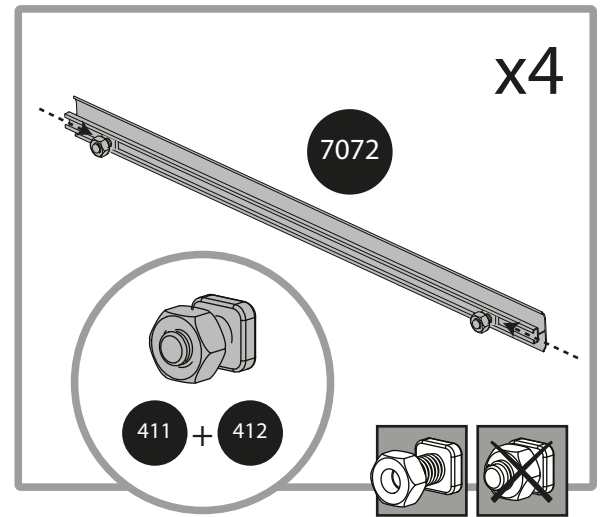
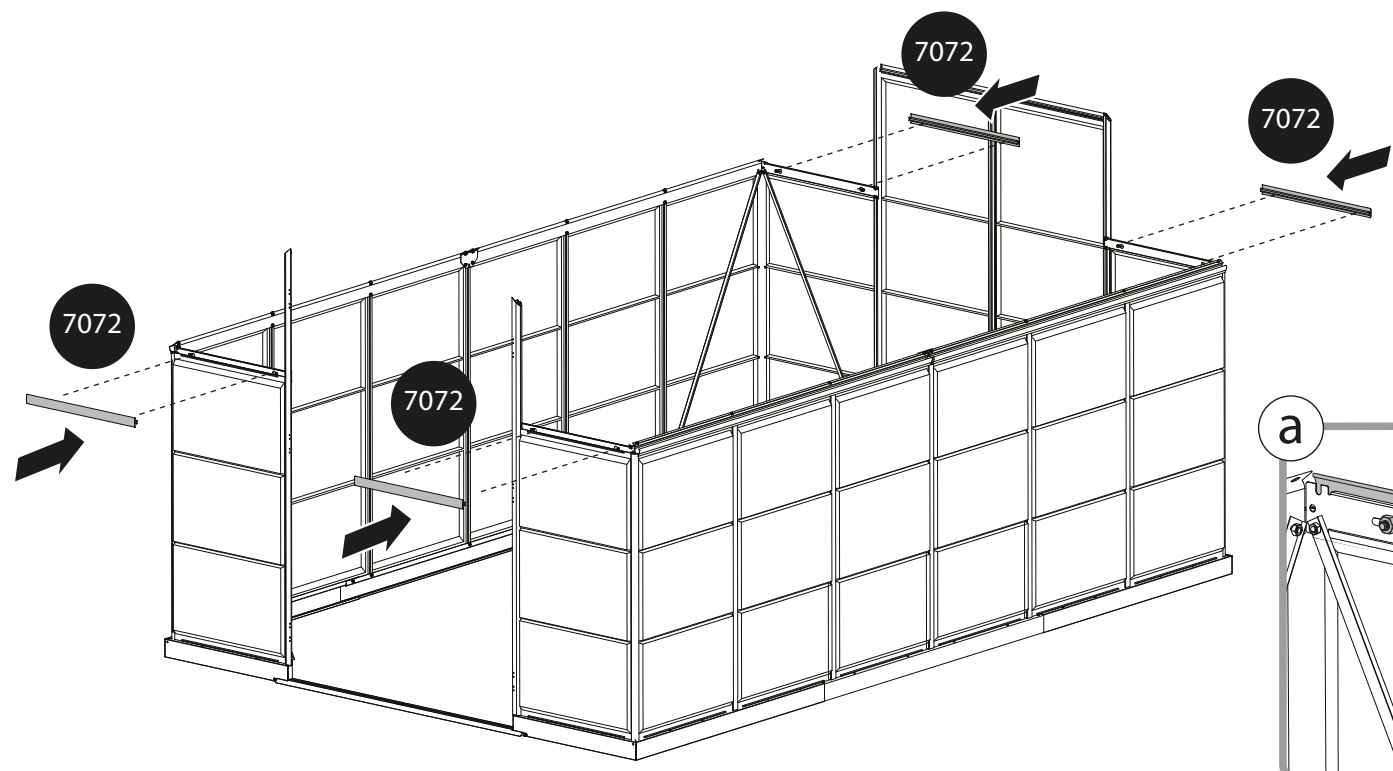

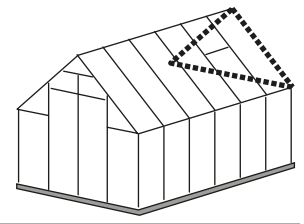

559

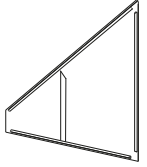

x1

560

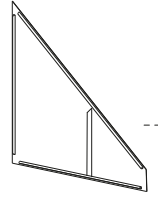

x1

7068

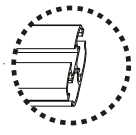

x1

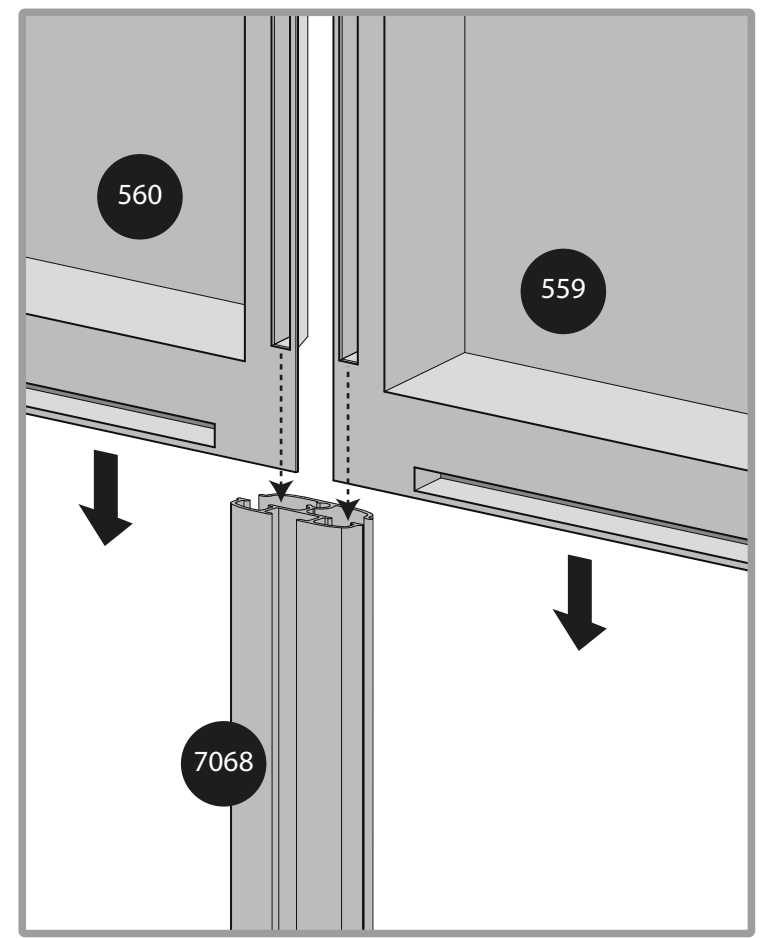
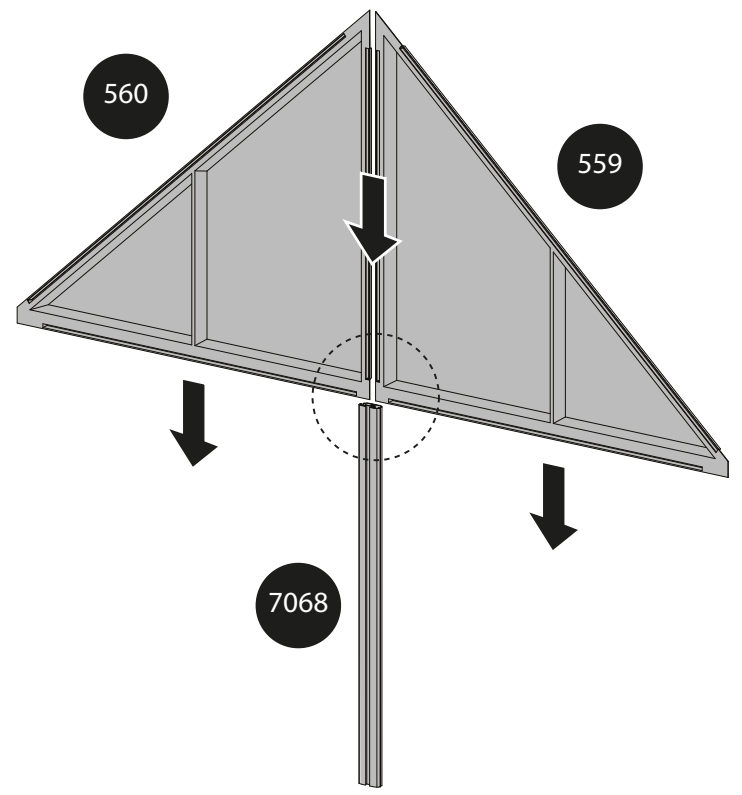

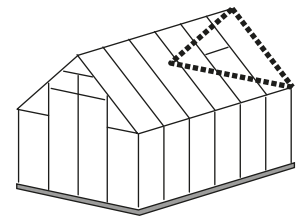

7076
412 x2 411 x2

a

b

c

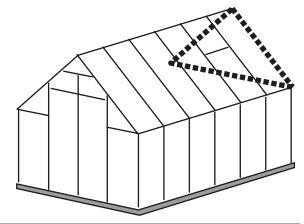

7061

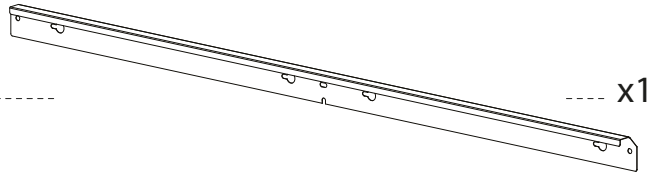

412



x3

411



x3

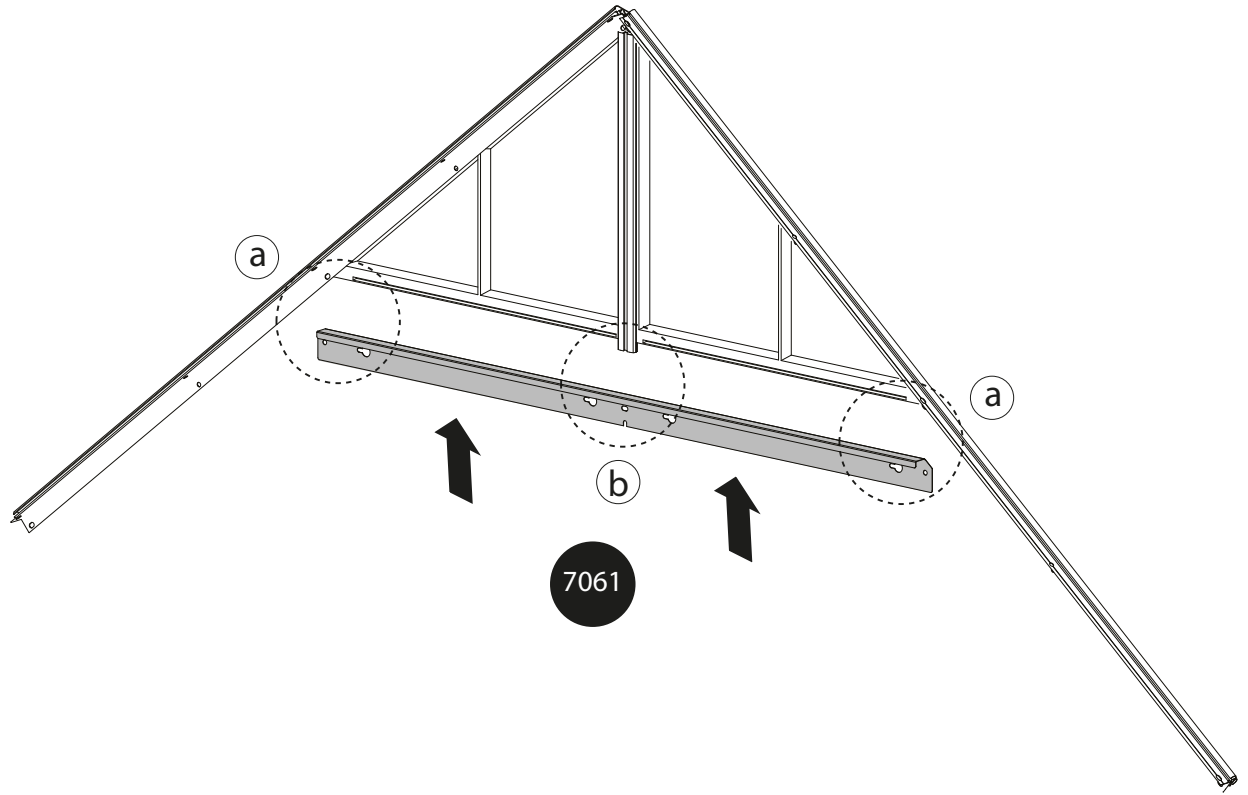

a

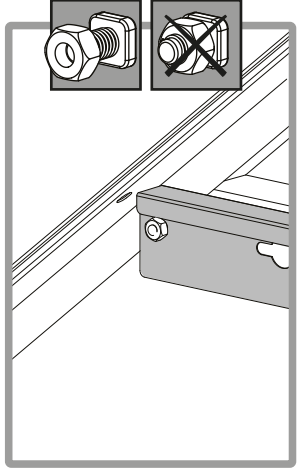
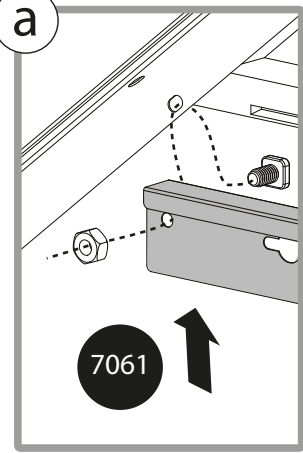

b

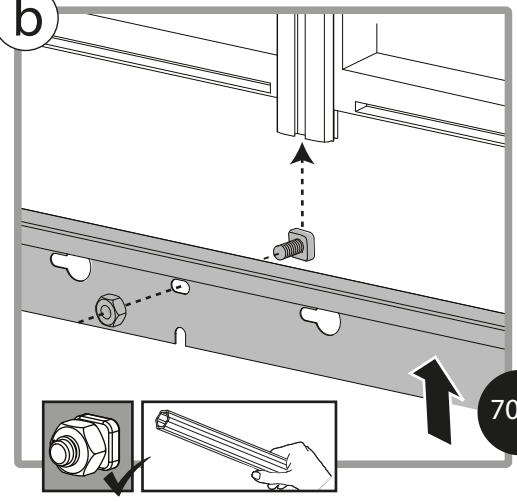

7061

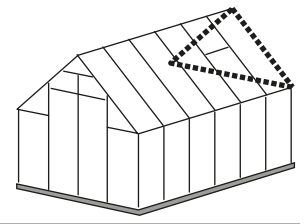

7072

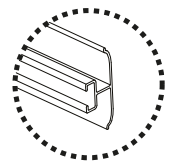
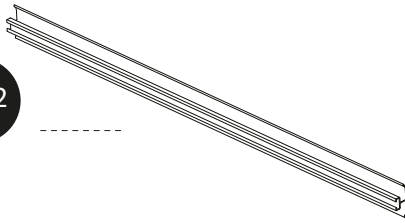

x2

412



x4

411



x4

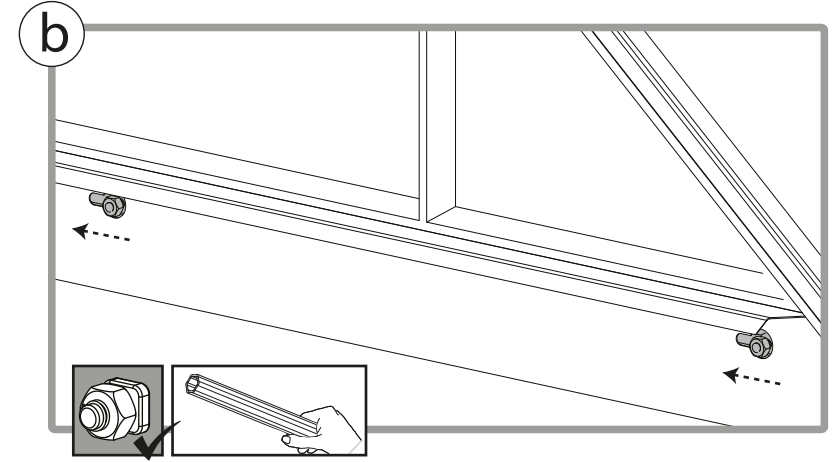
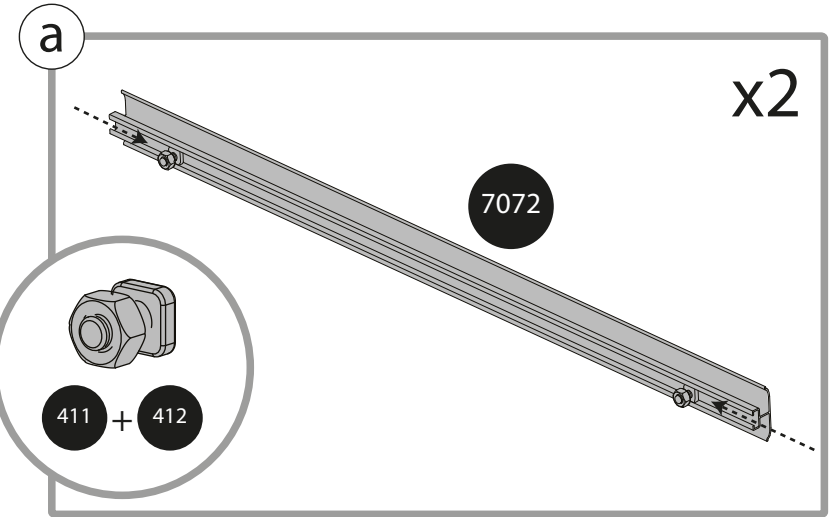
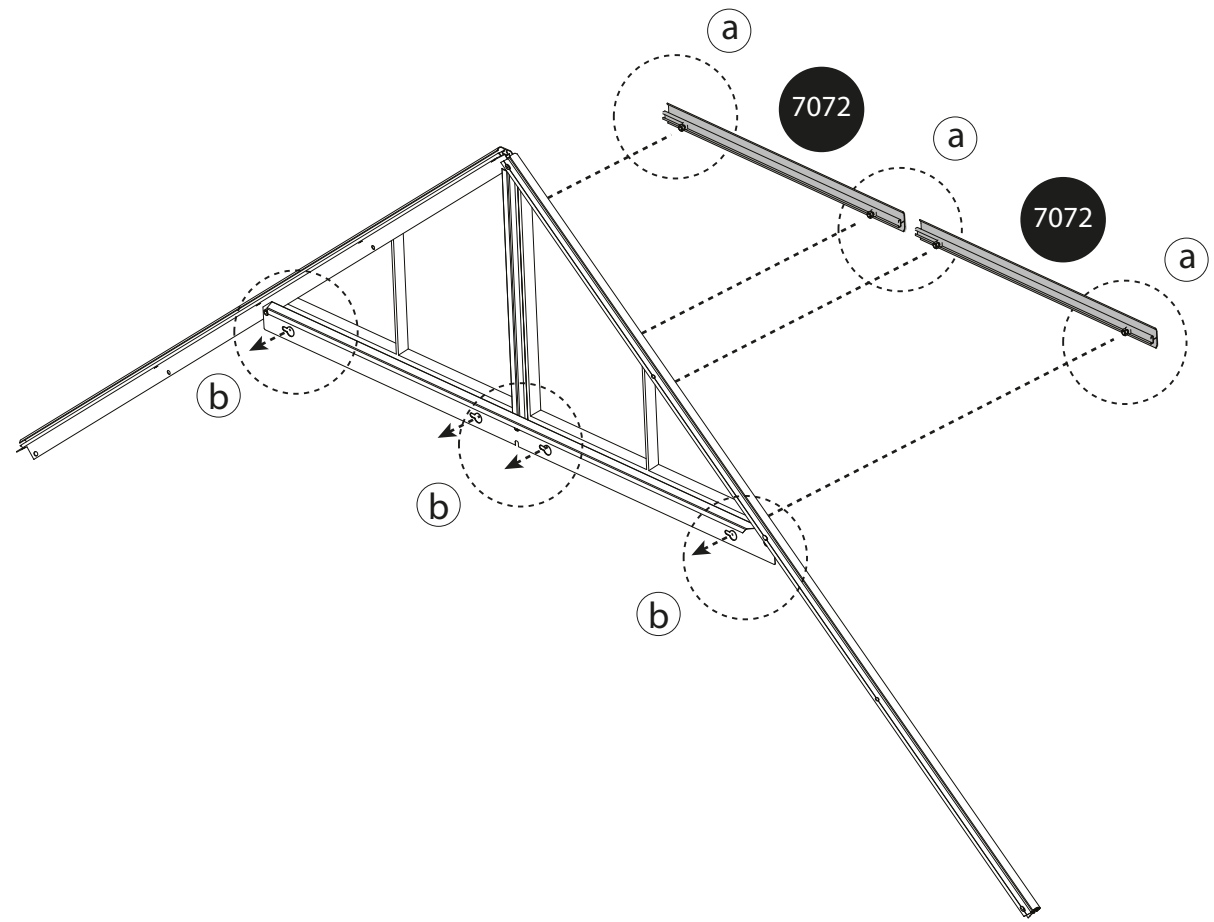

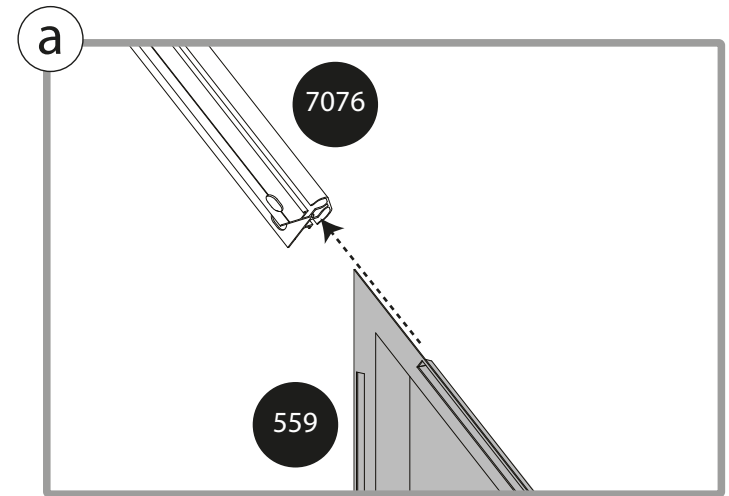
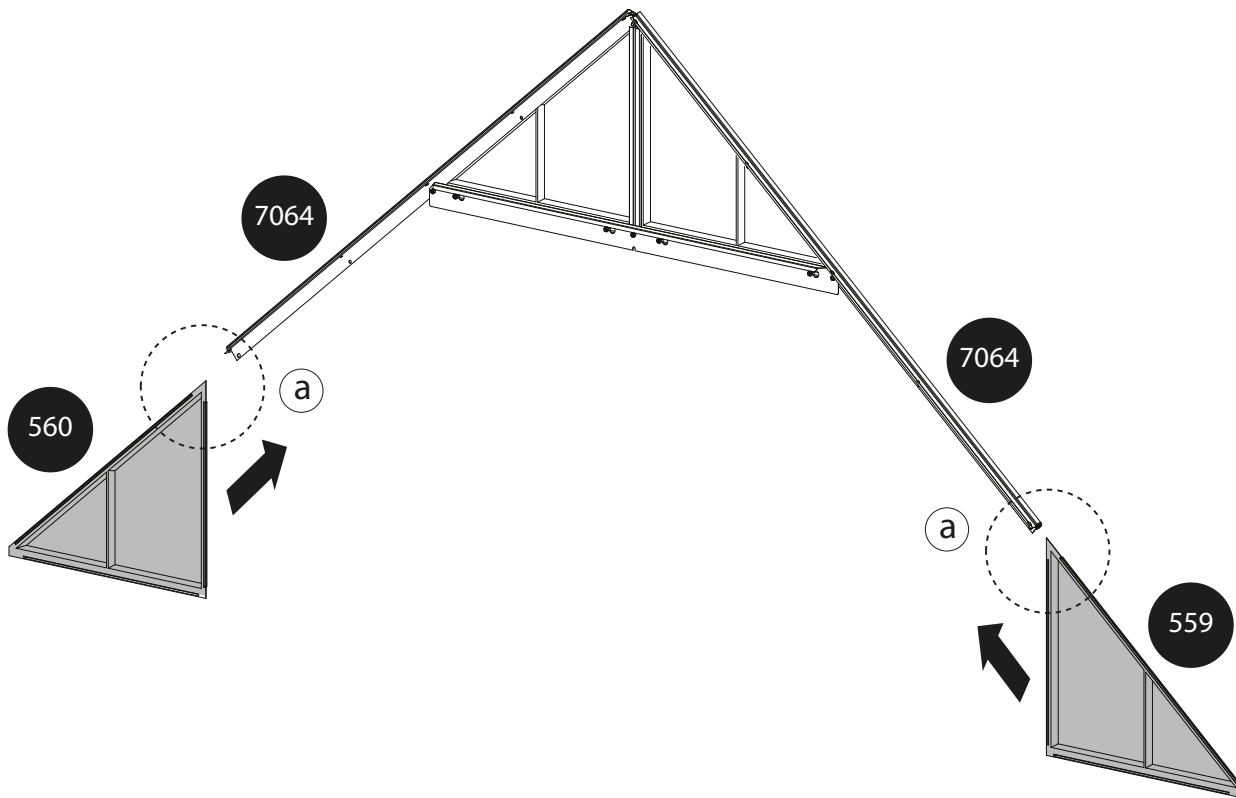
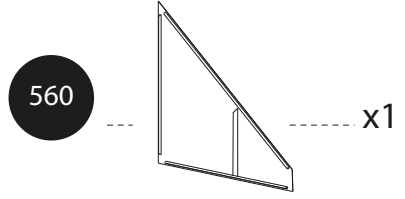
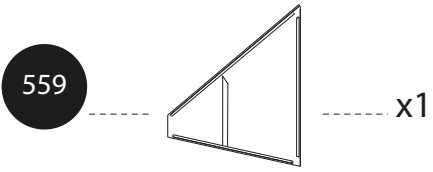
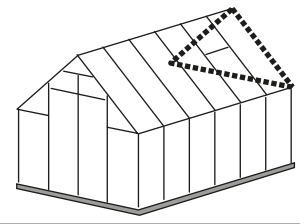

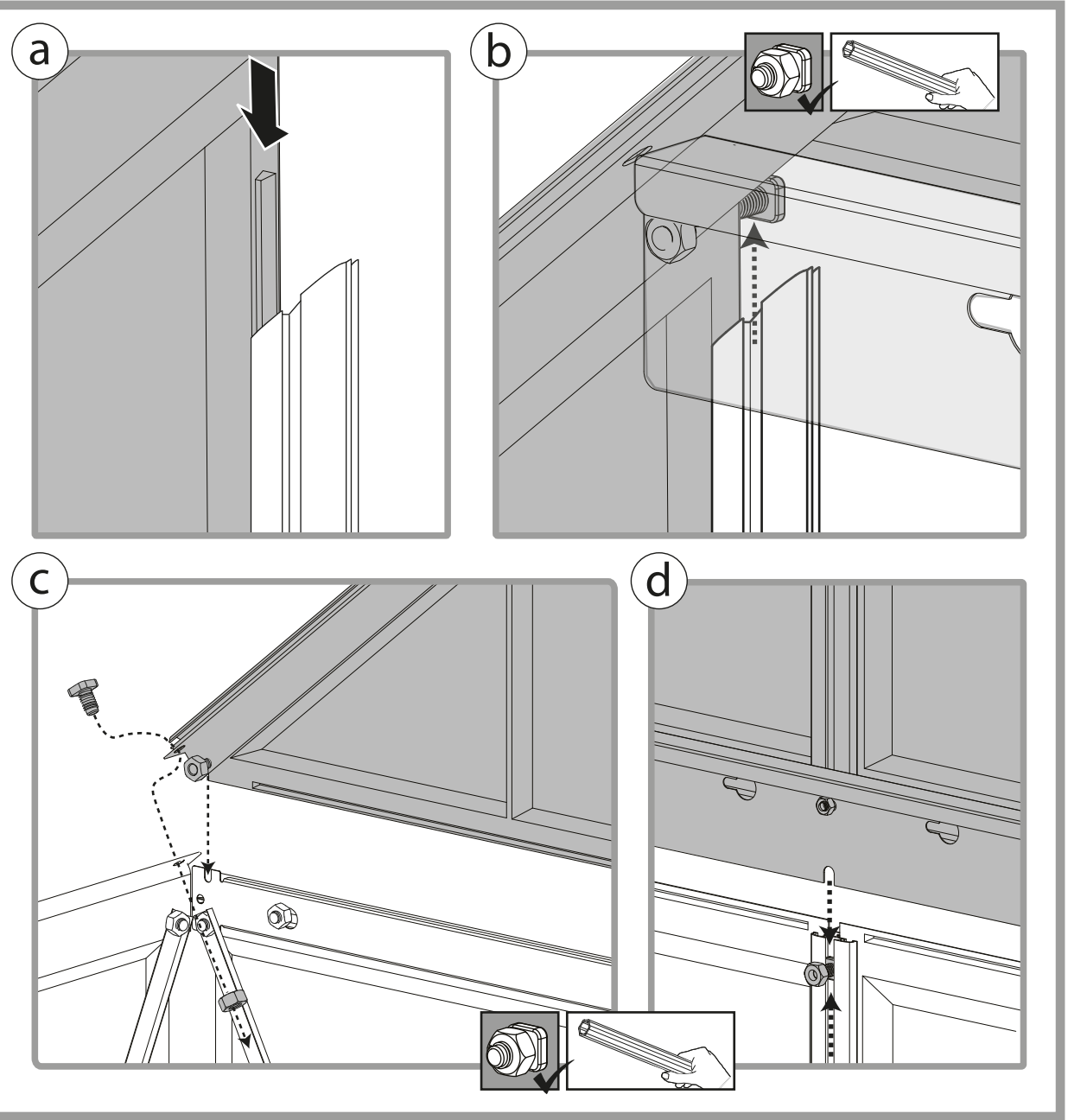
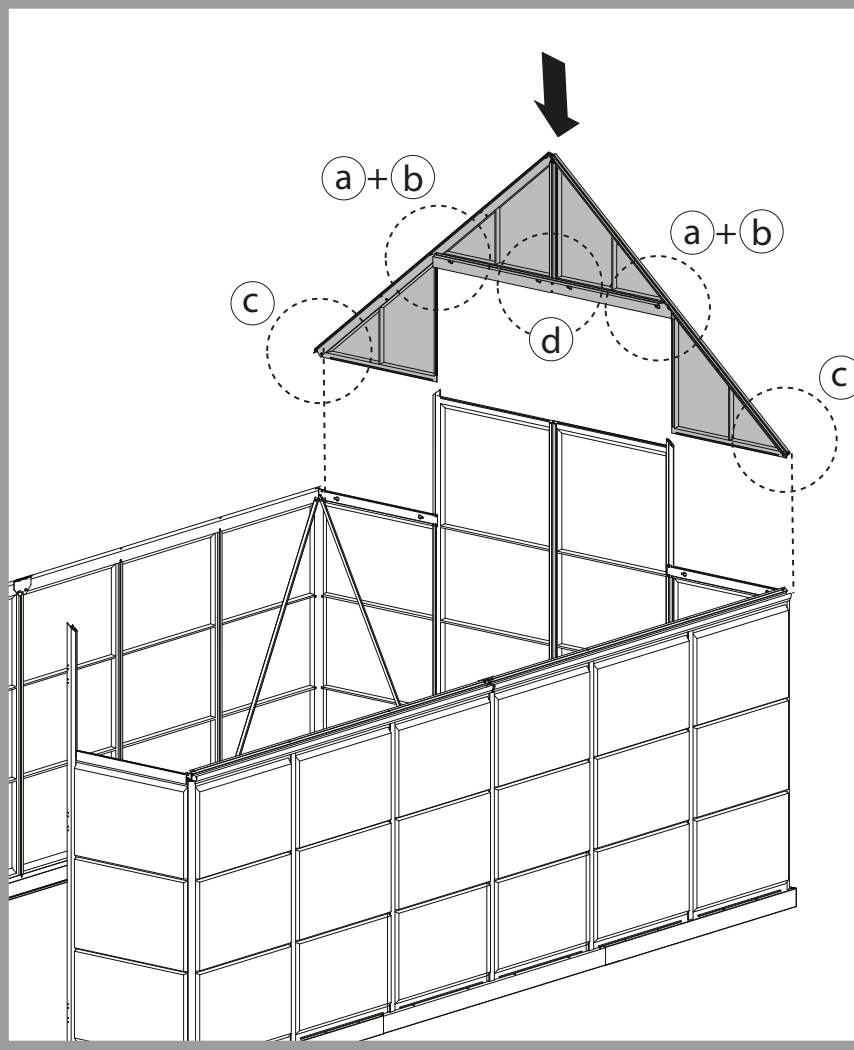
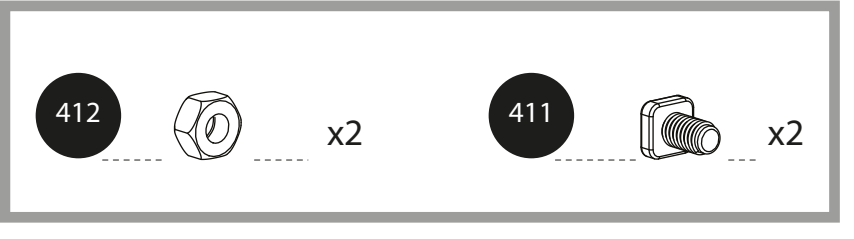
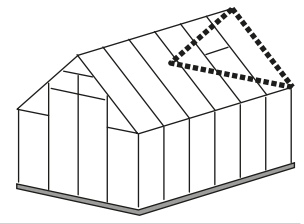

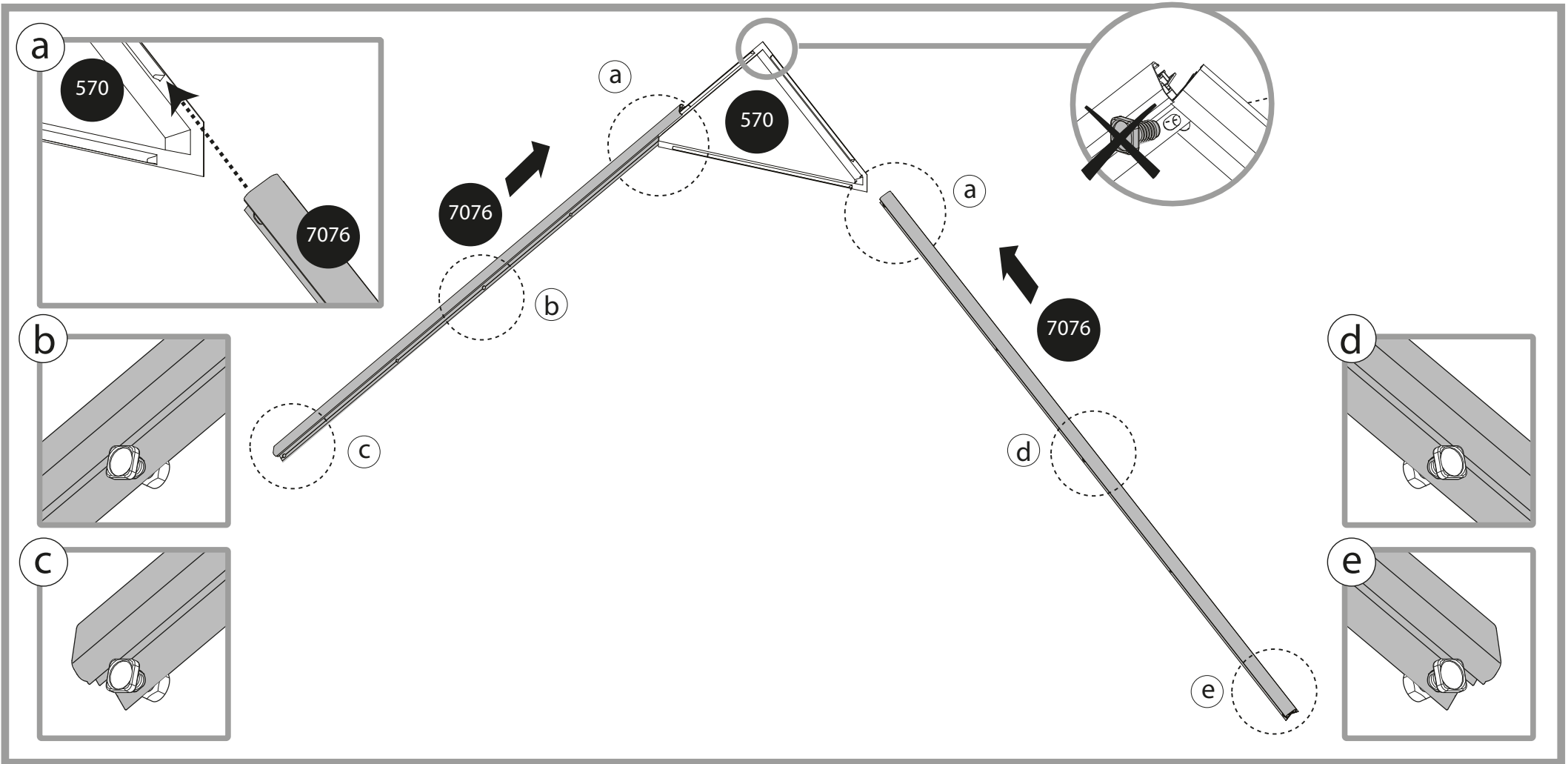
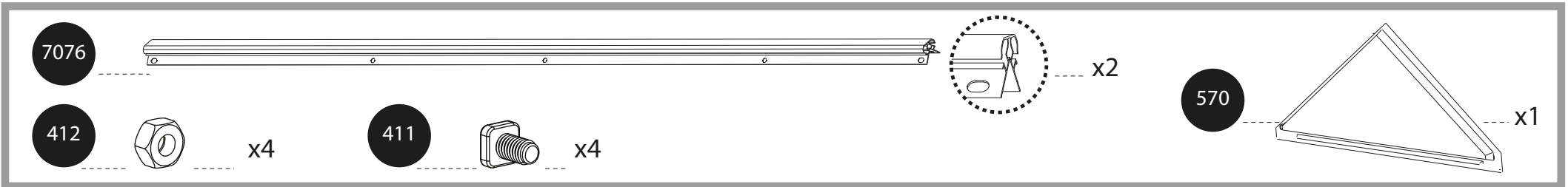

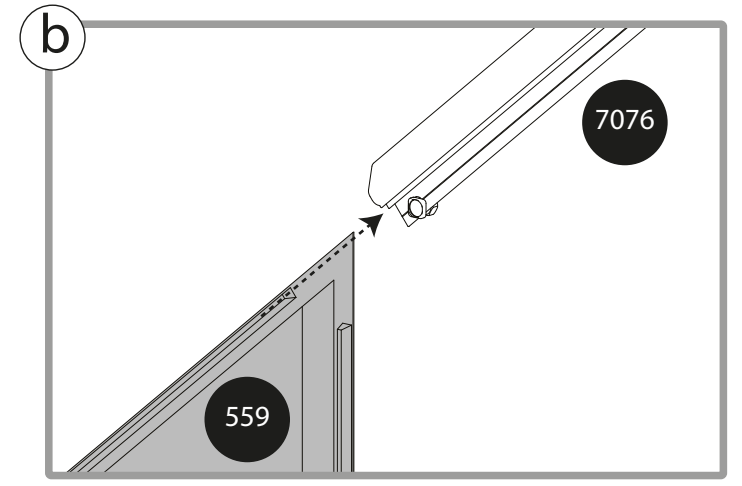
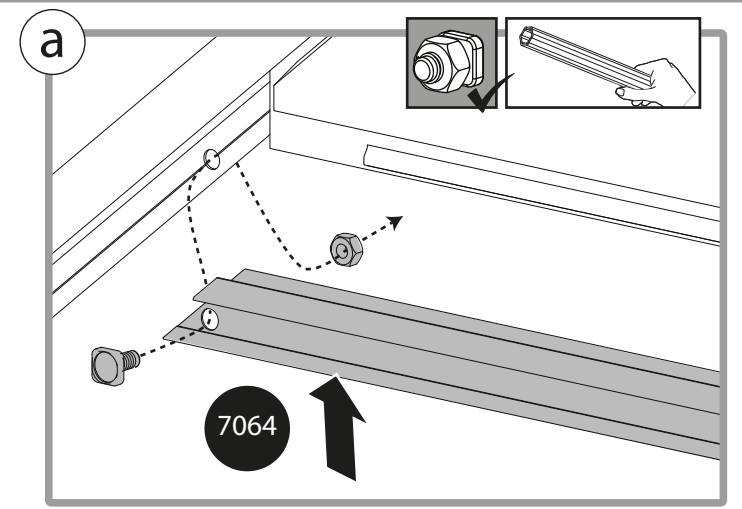
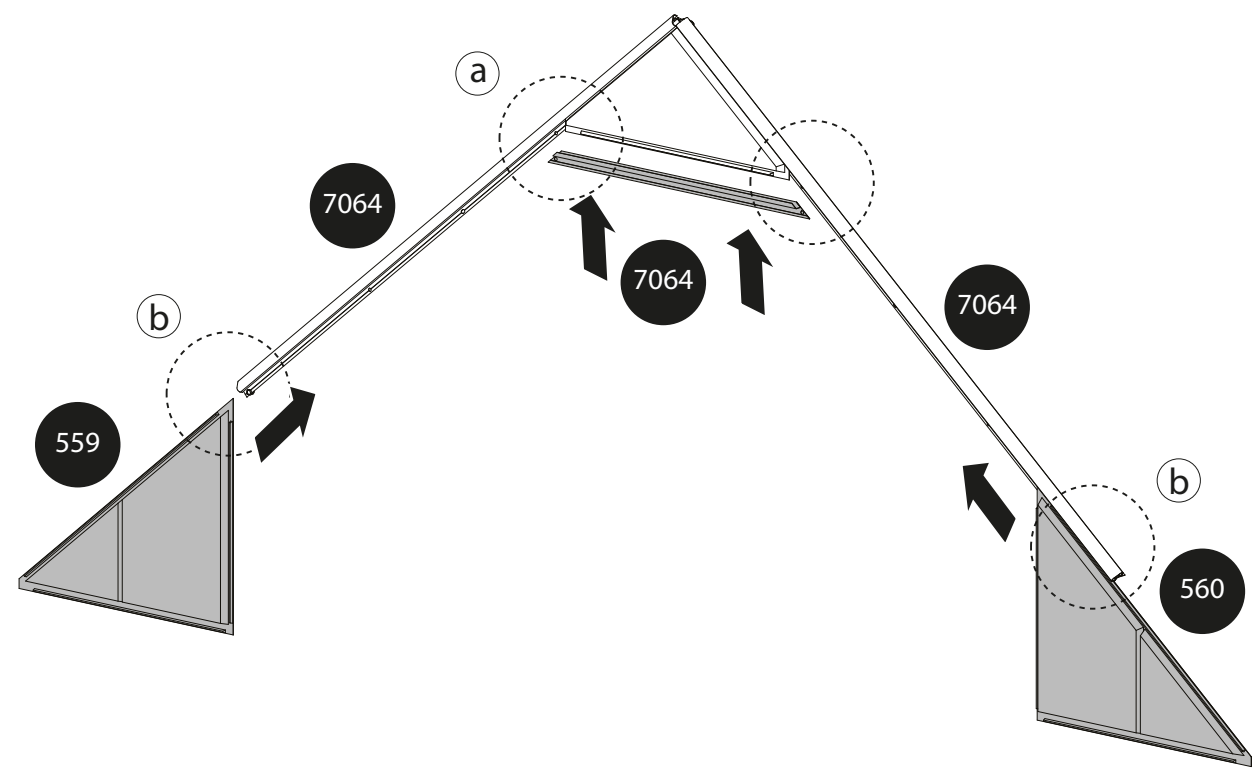
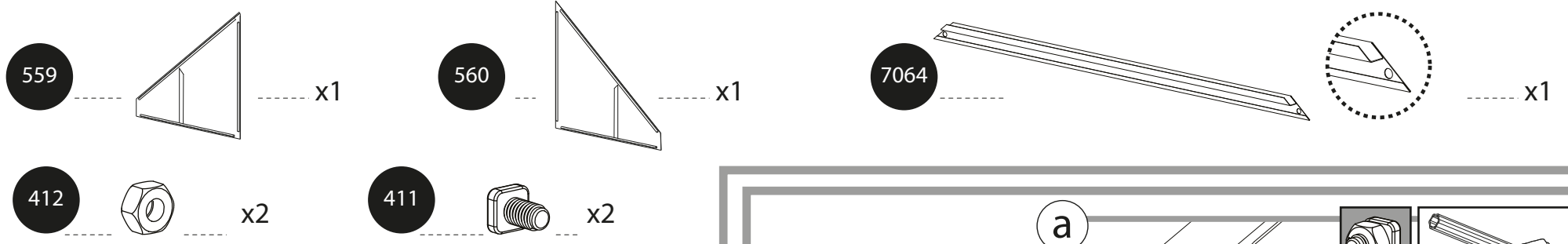
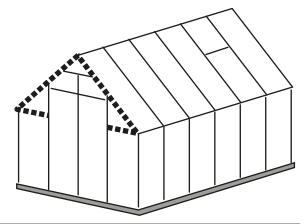

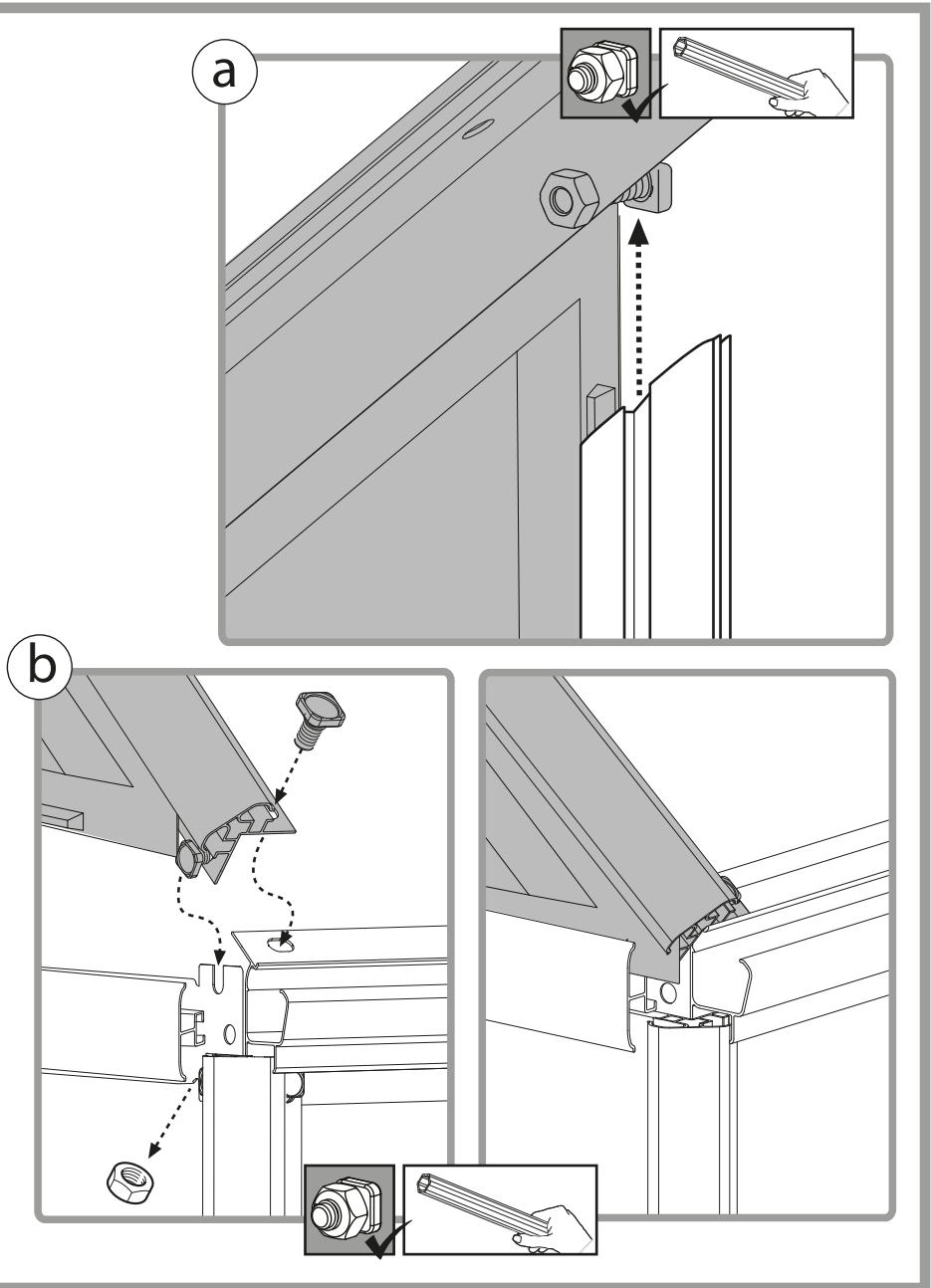
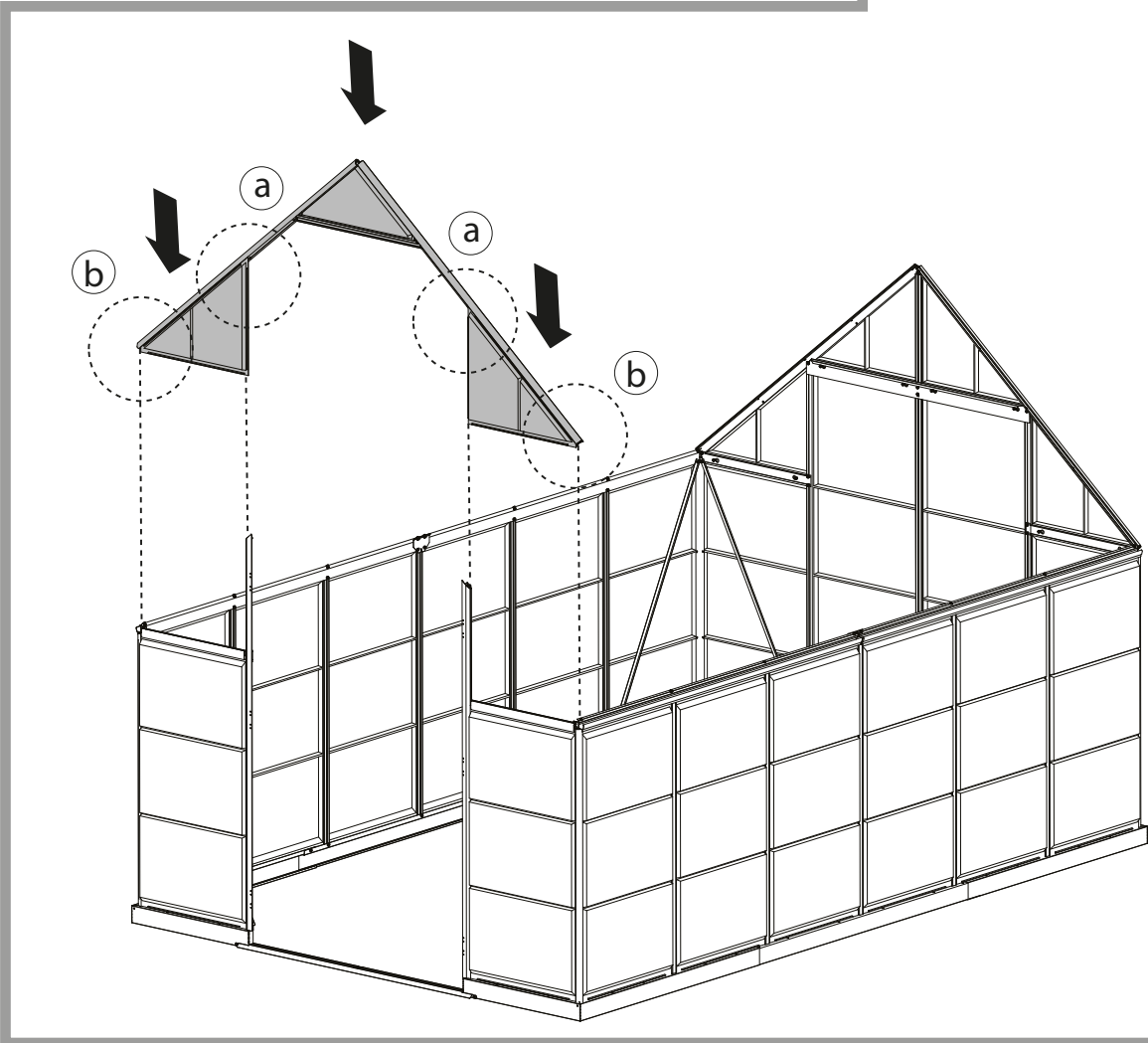
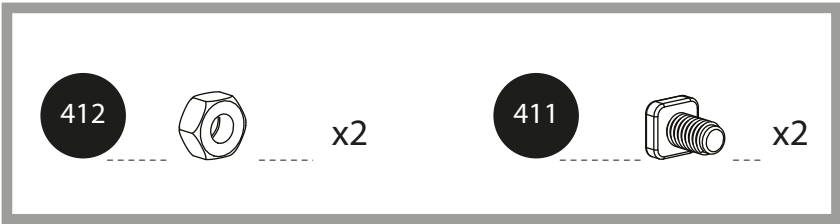
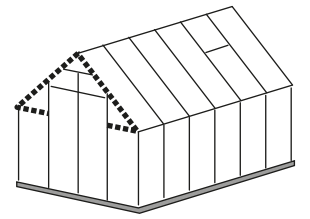

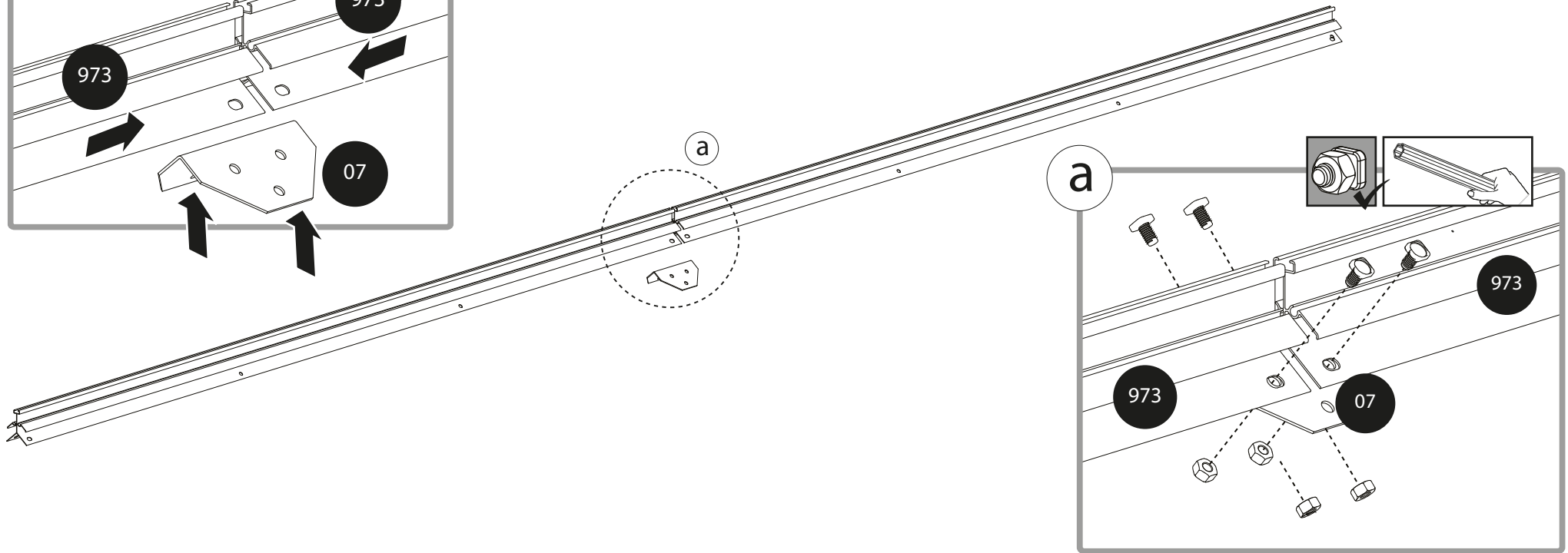
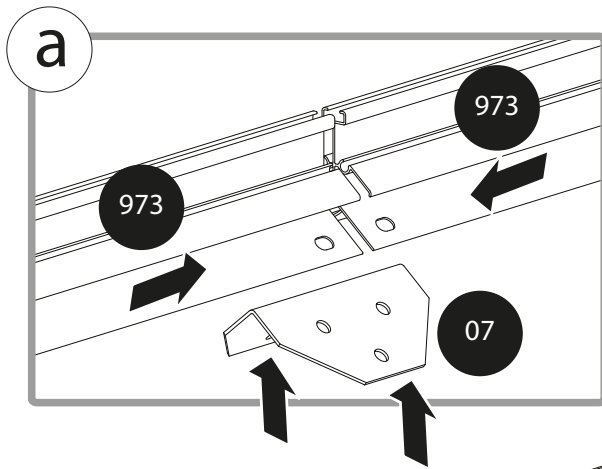
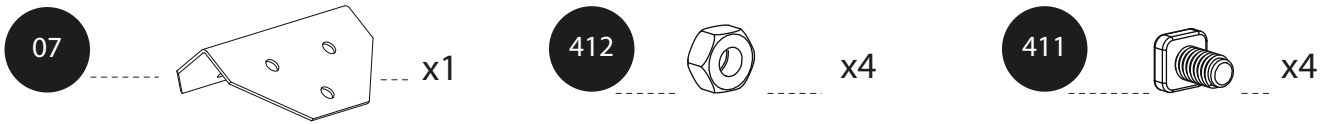
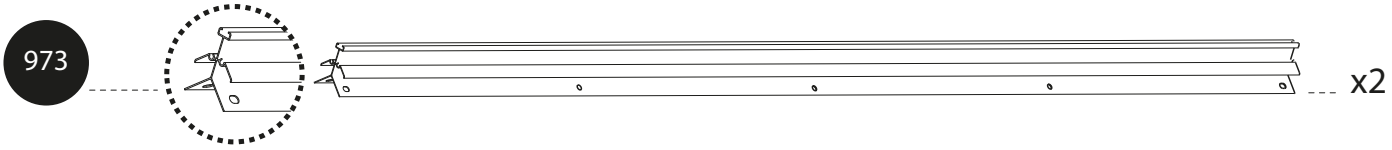
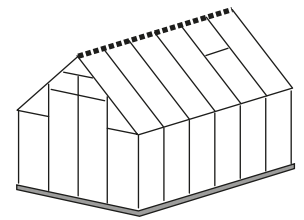

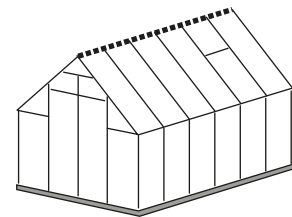

- 412  x10
- 411  x10

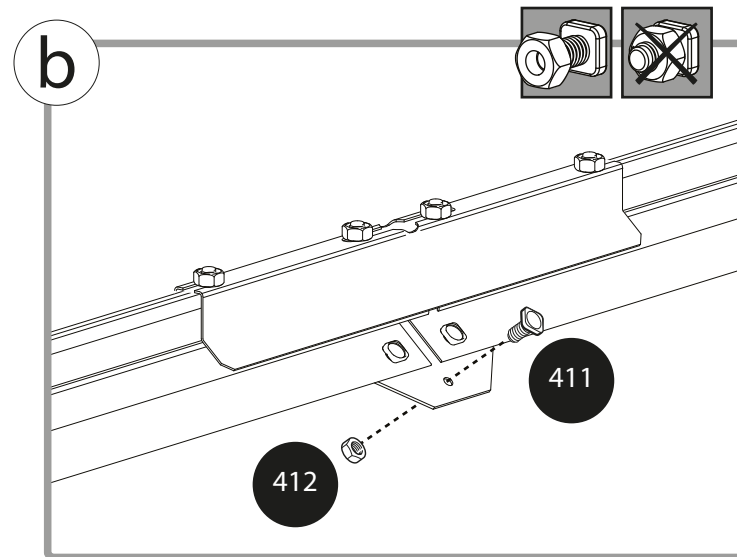
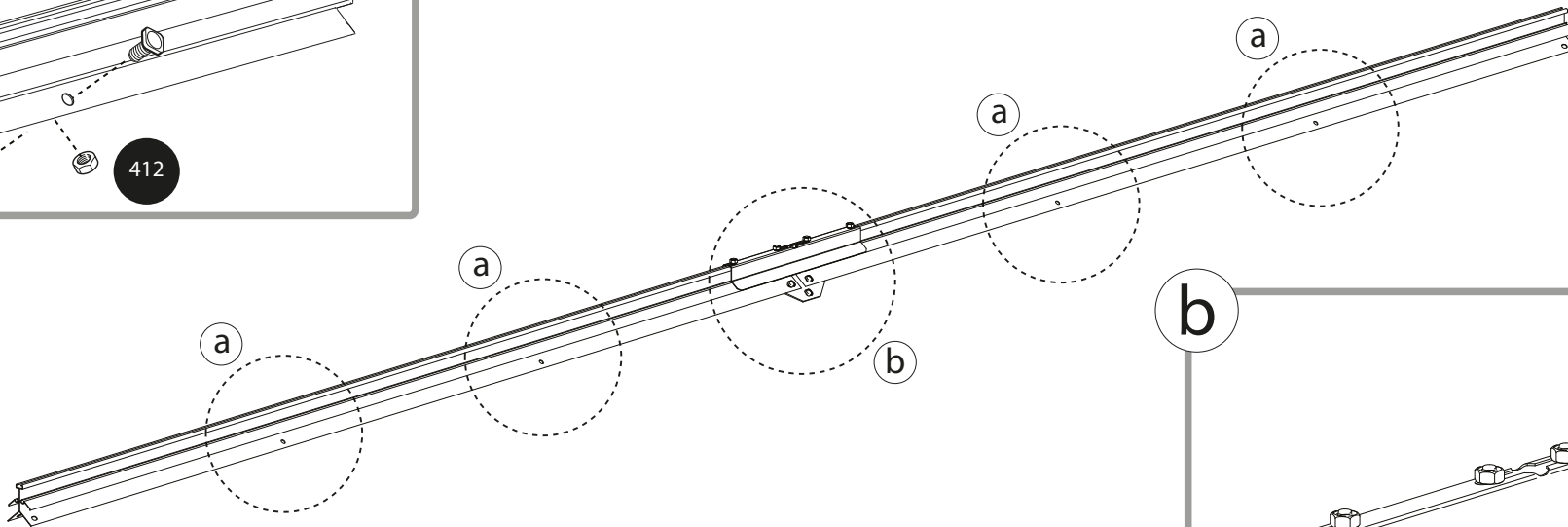
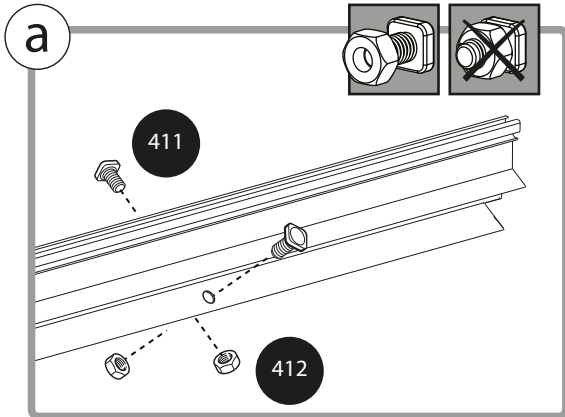

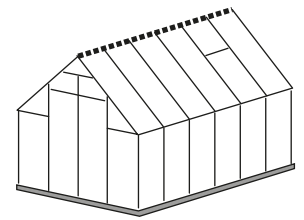

973

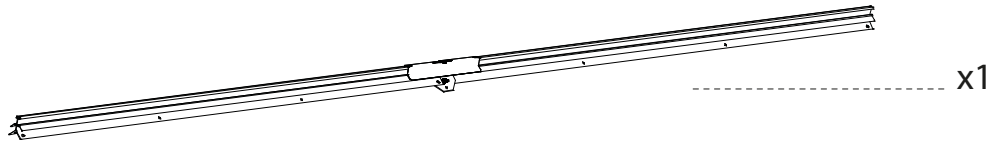
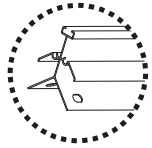

412



x4

411



x4

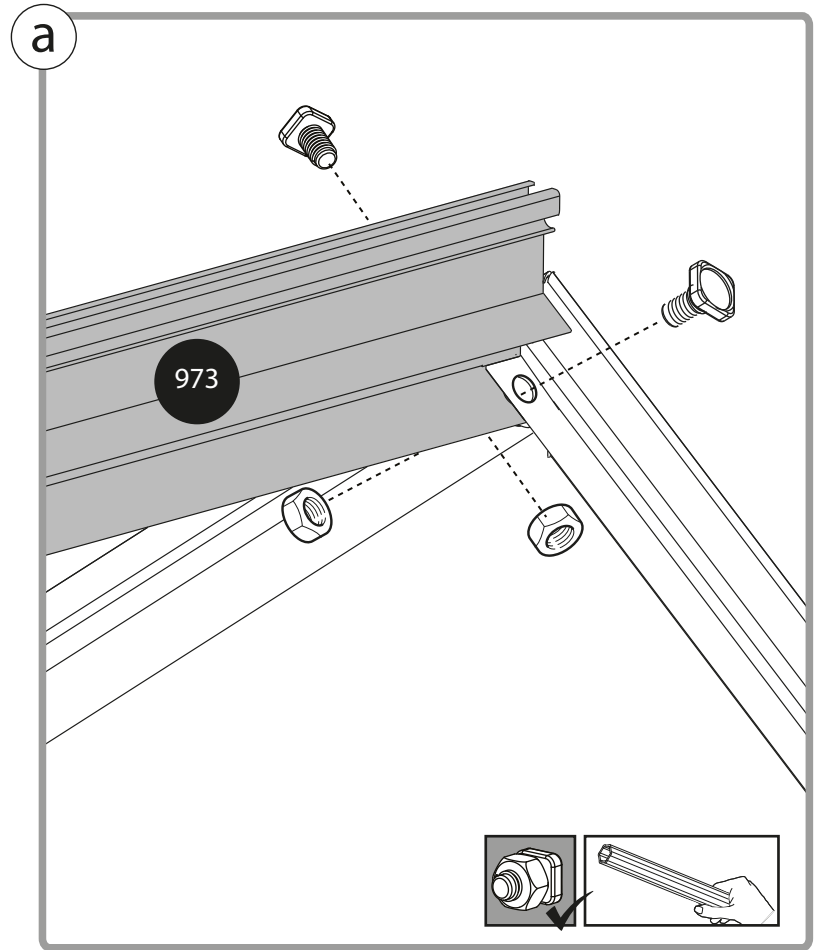
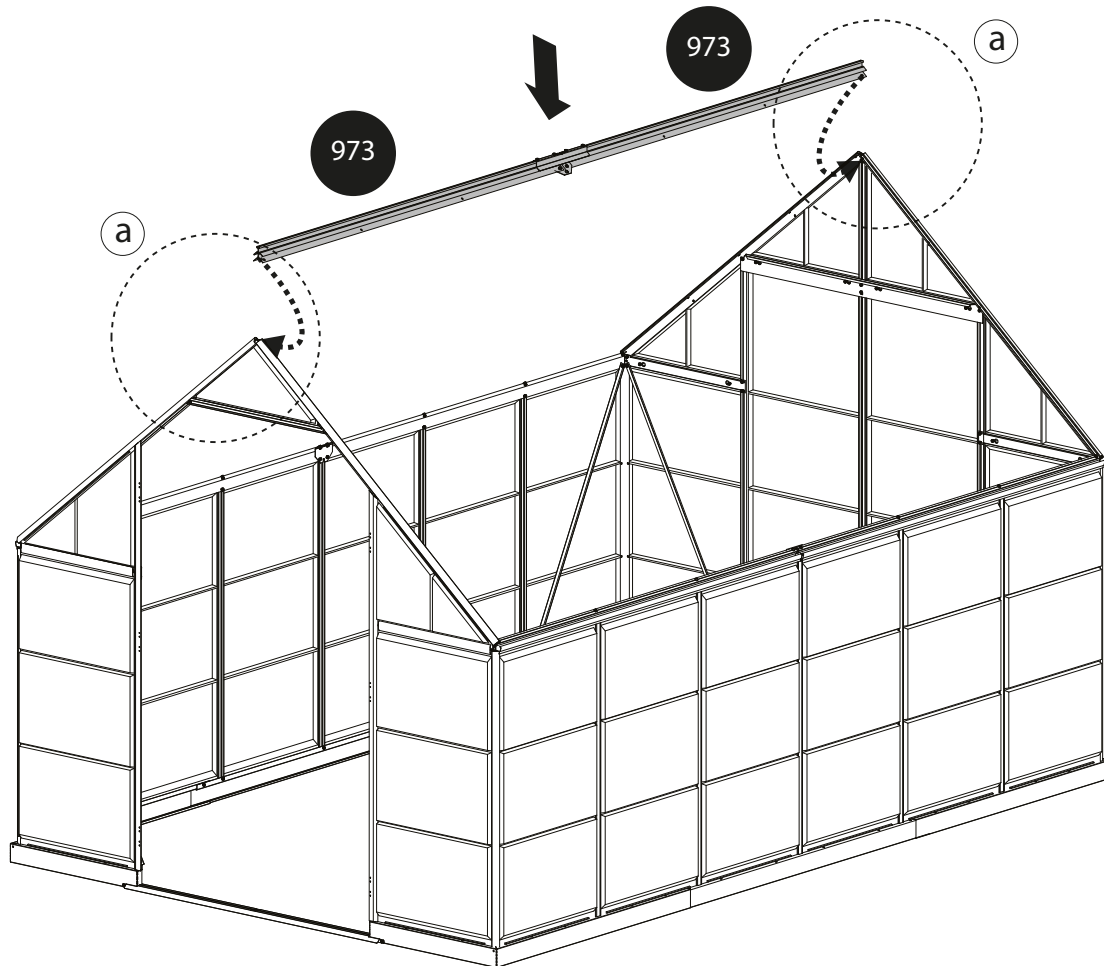

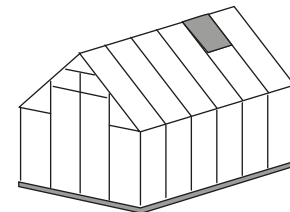

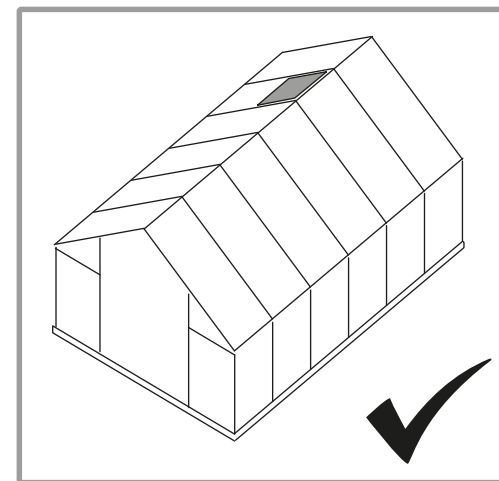
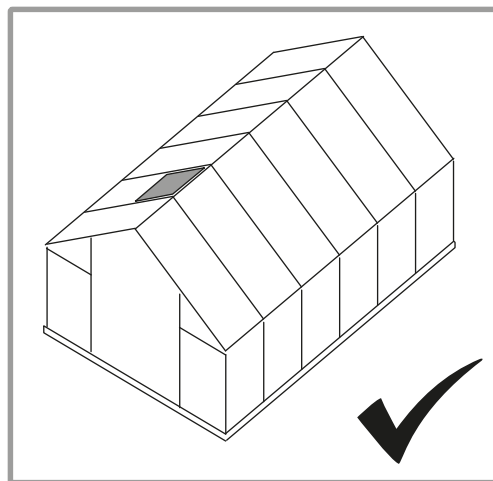
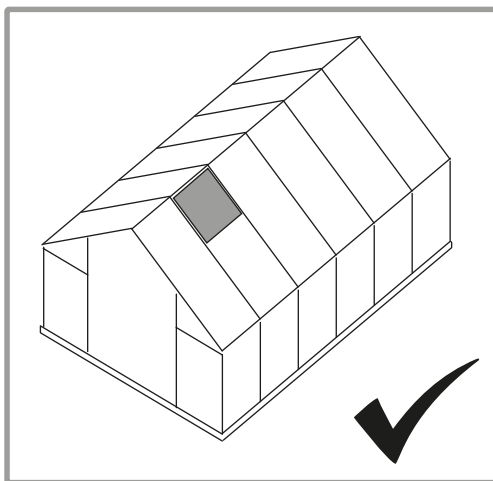
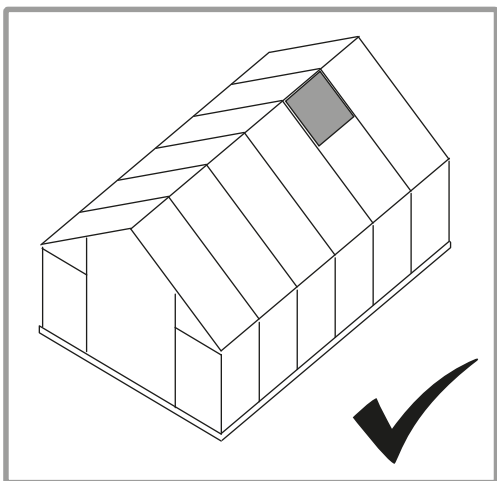

EN Window Location
GR Fenster Standort
FR Fenêtre Emplacement
SP Ventana Ubicación

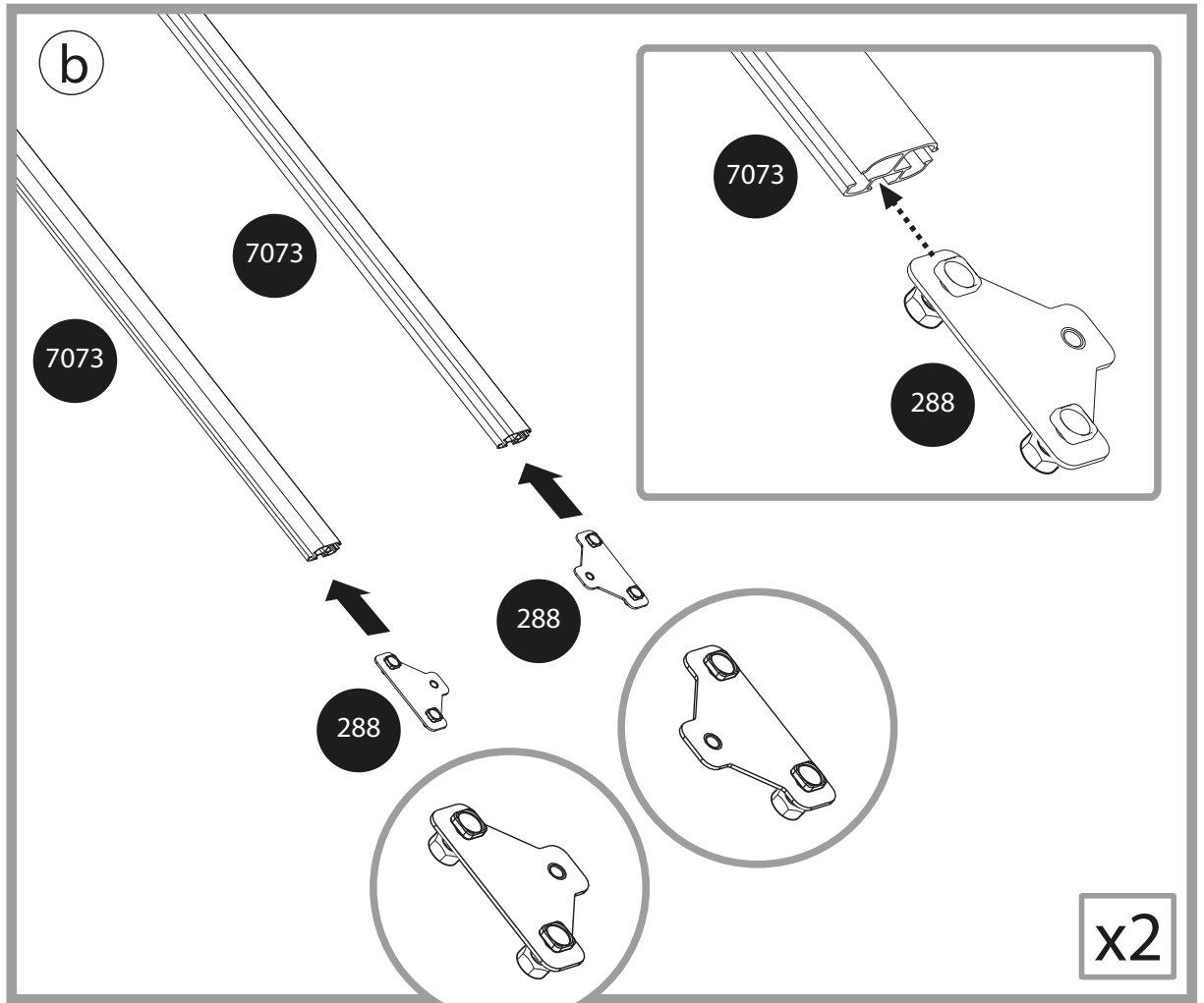
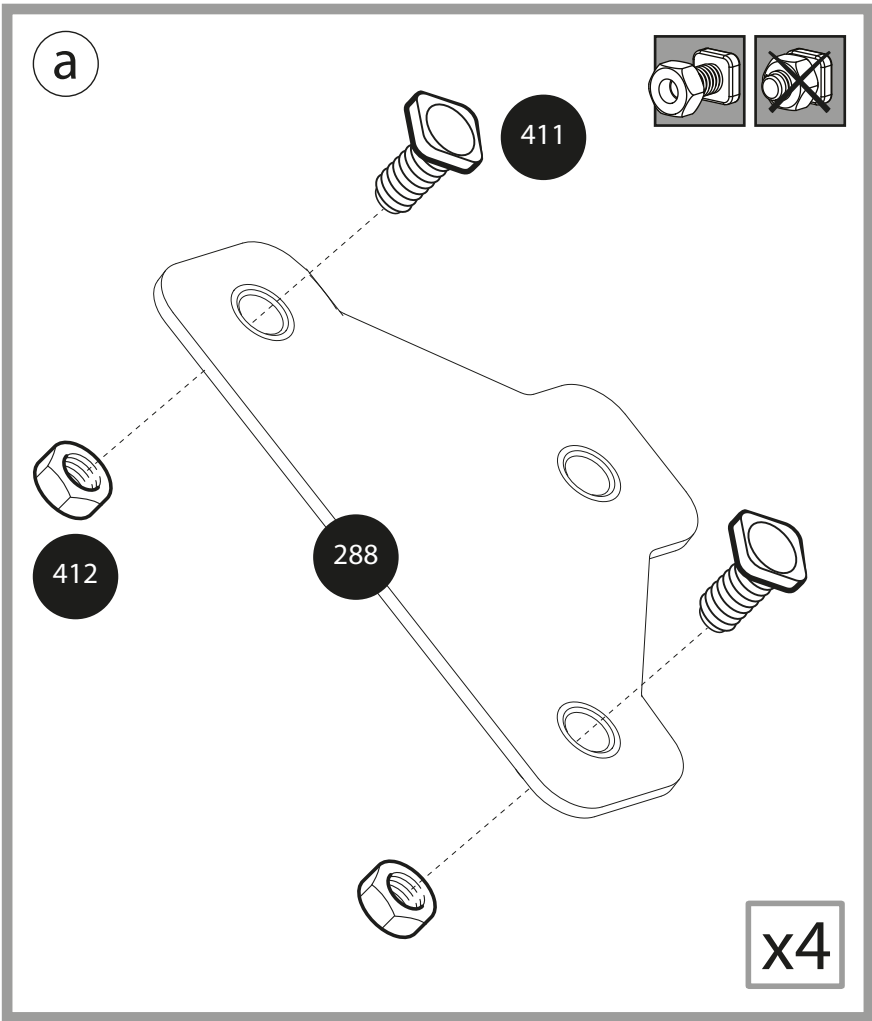
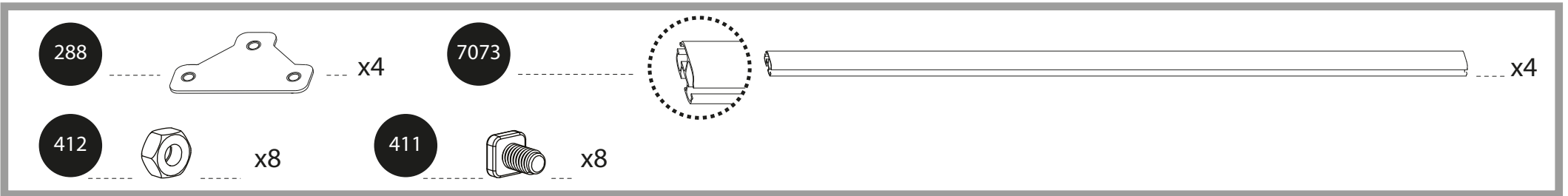
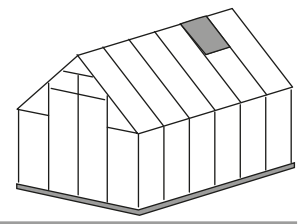

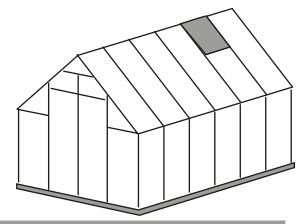

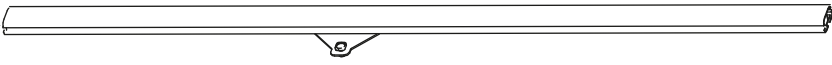
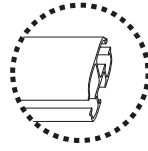

7073   x4

412  x4

411  x4

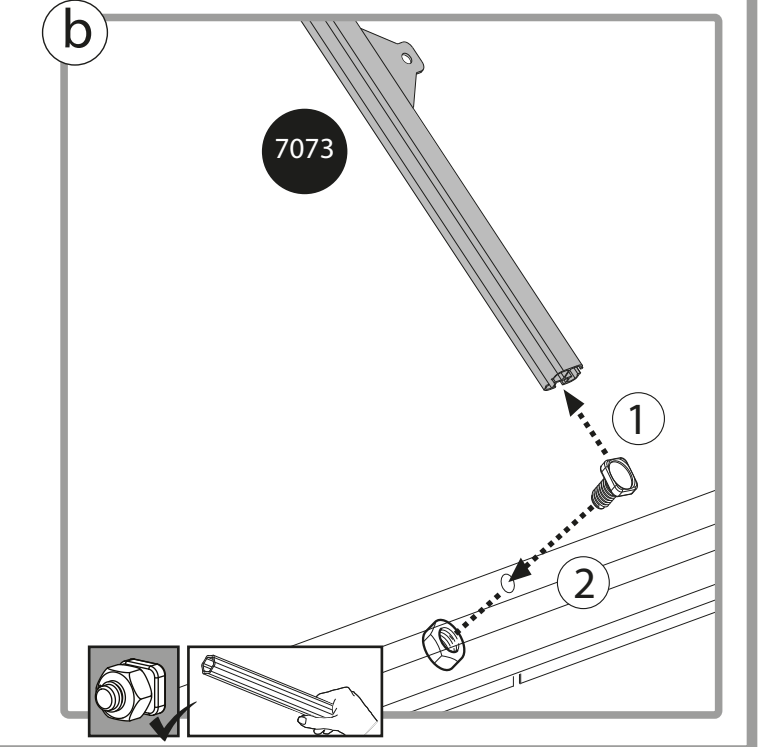
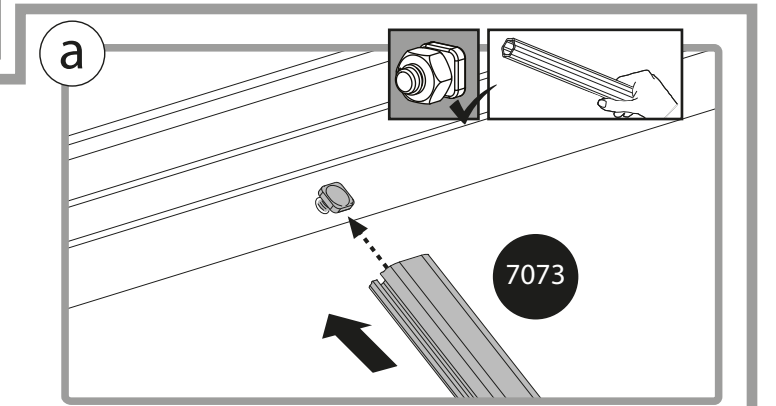
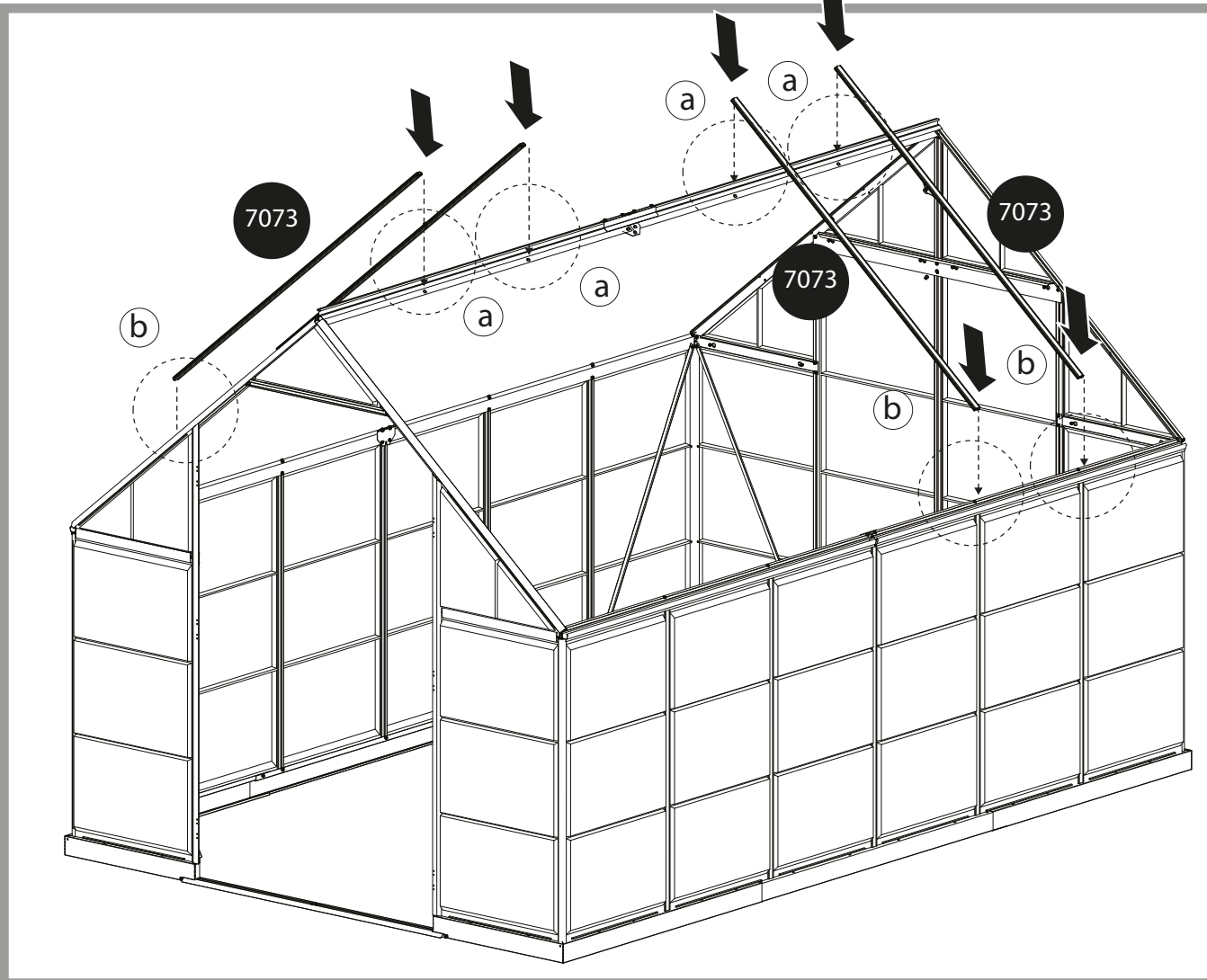

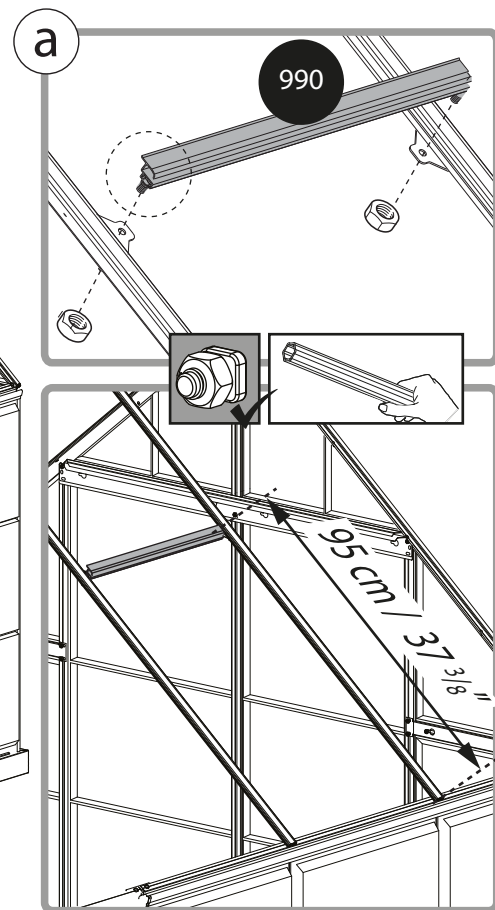
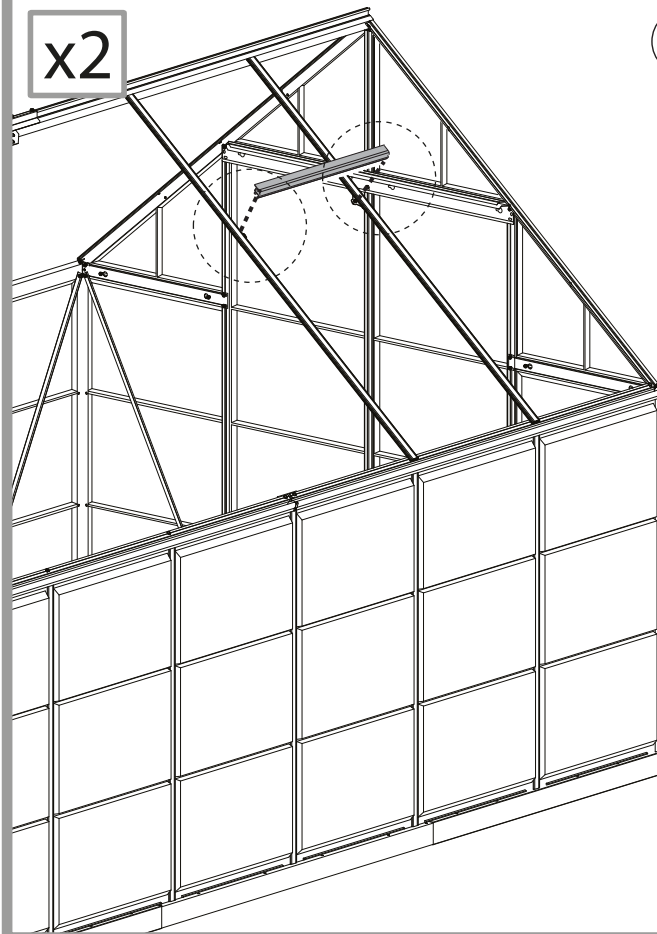
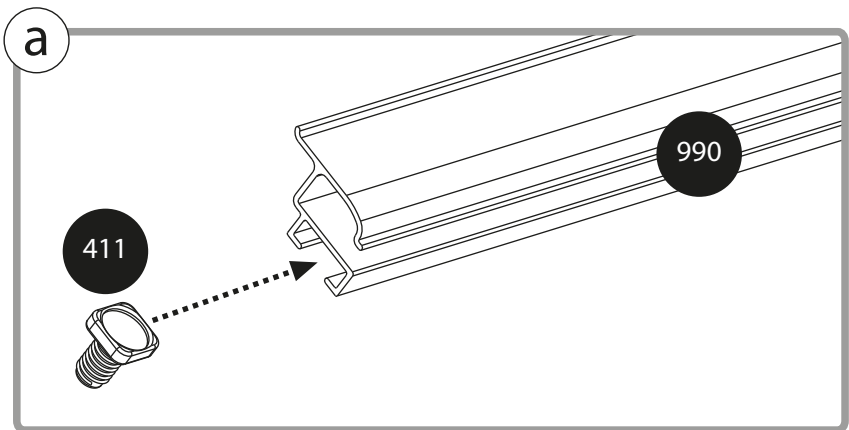
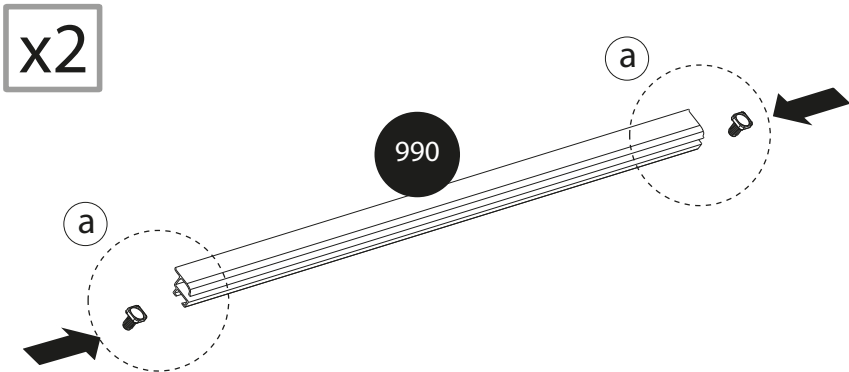
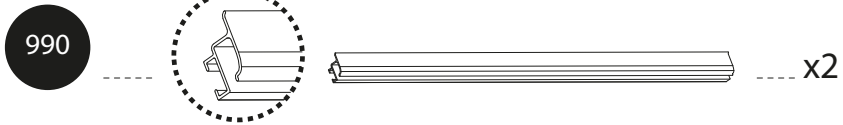
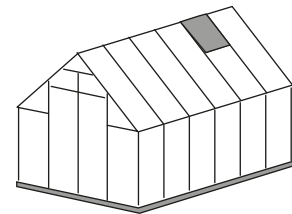

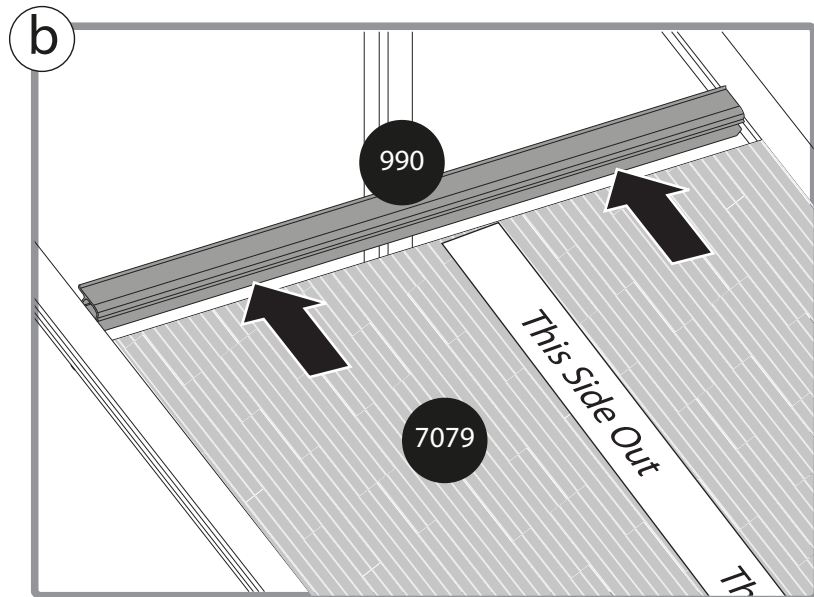
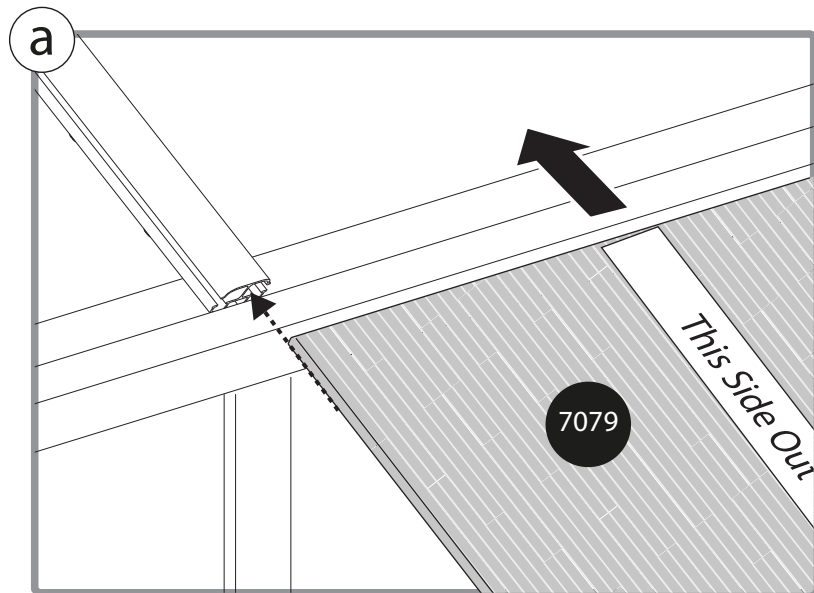
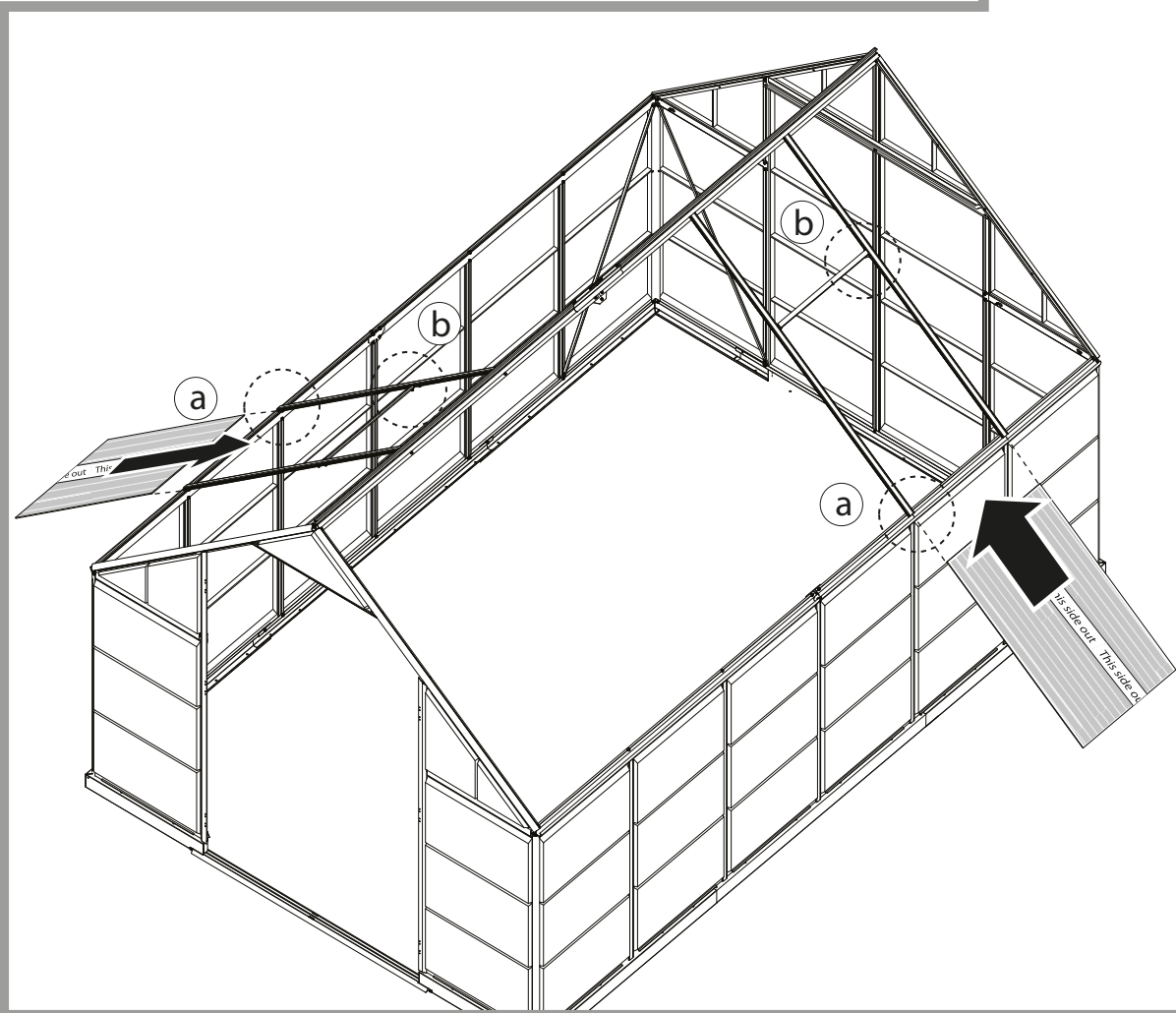
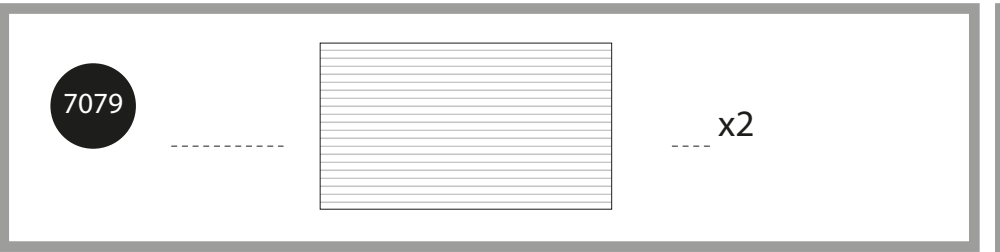
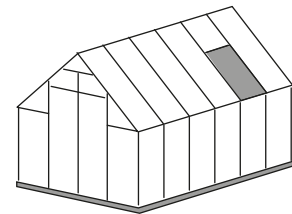

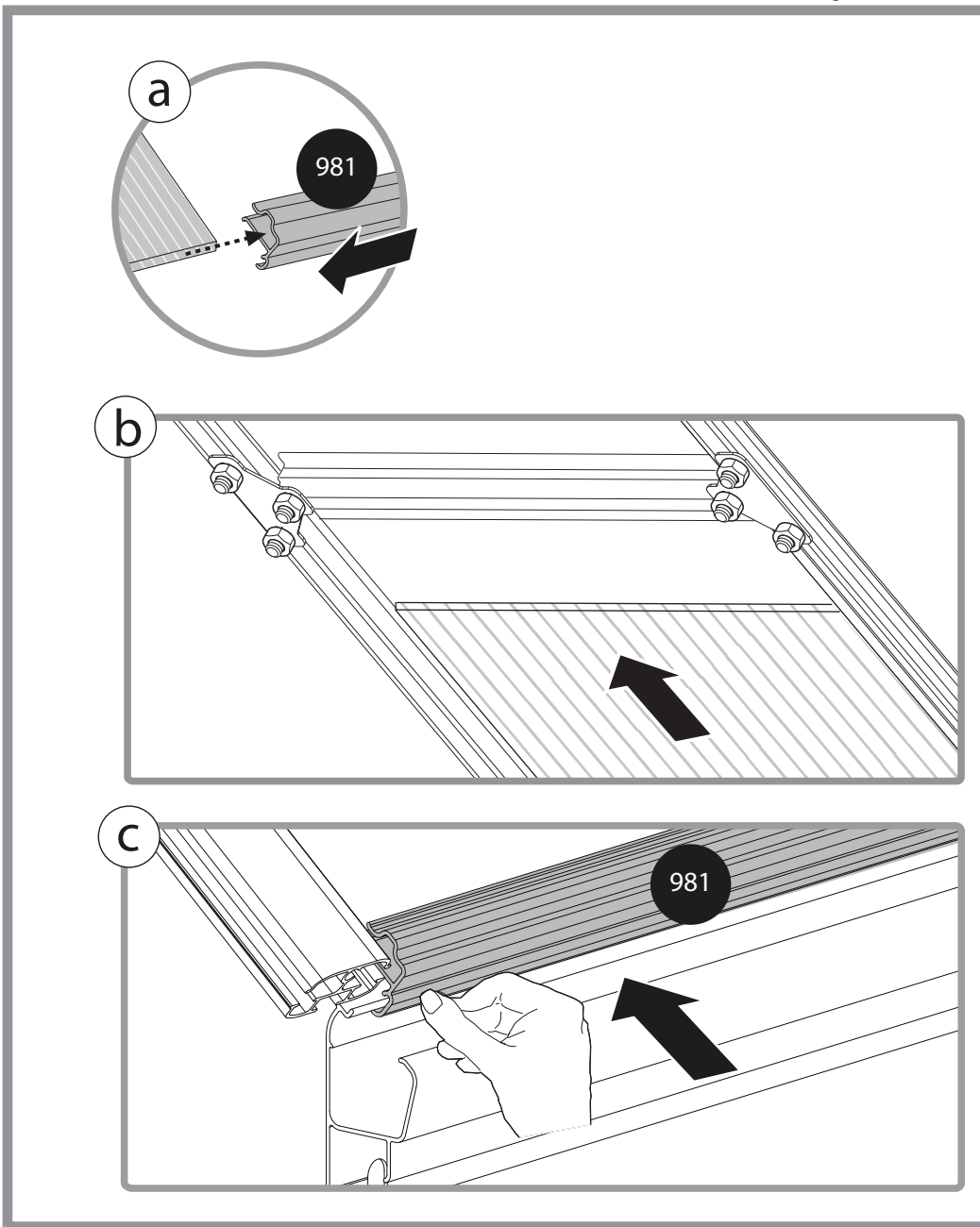
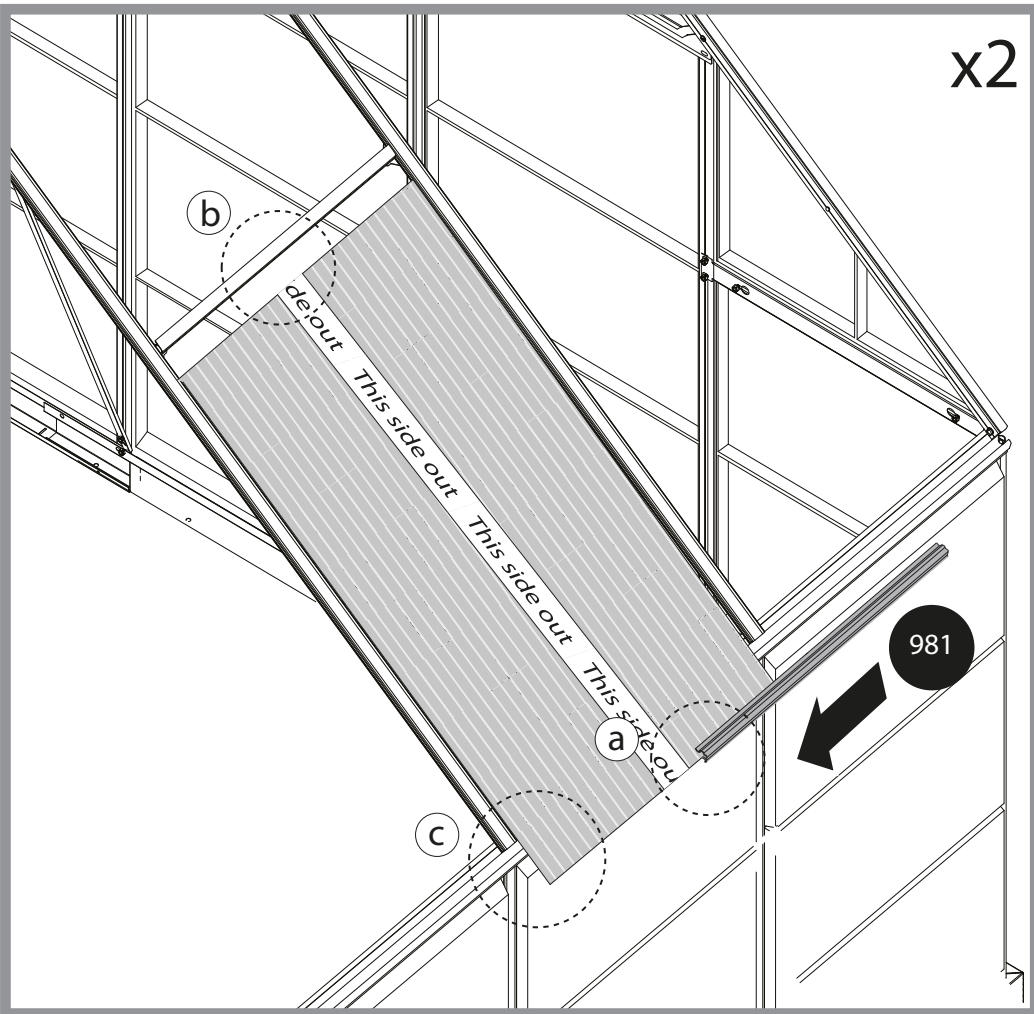
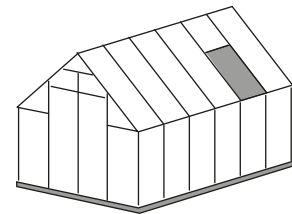

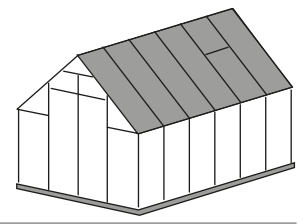

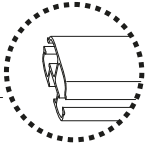

7073  x6 412  x4 411  x4

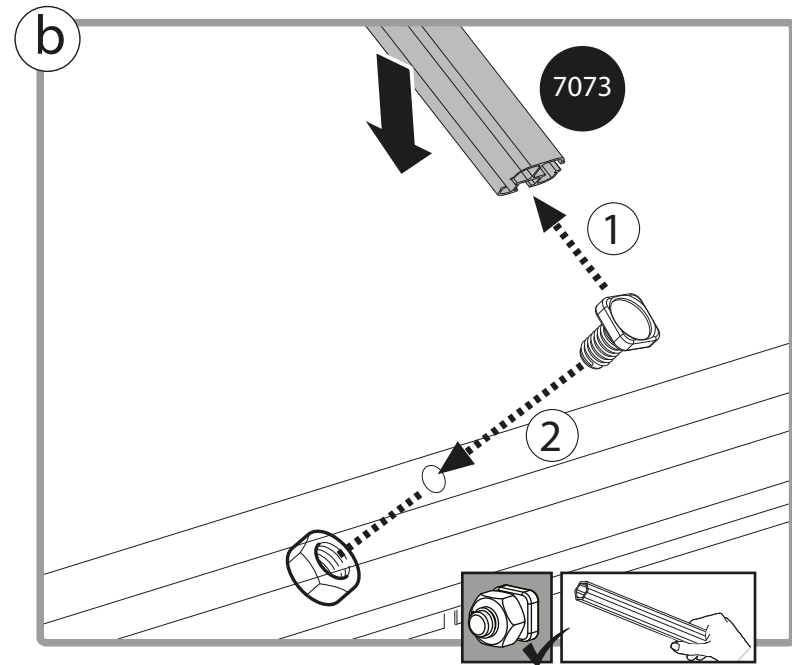
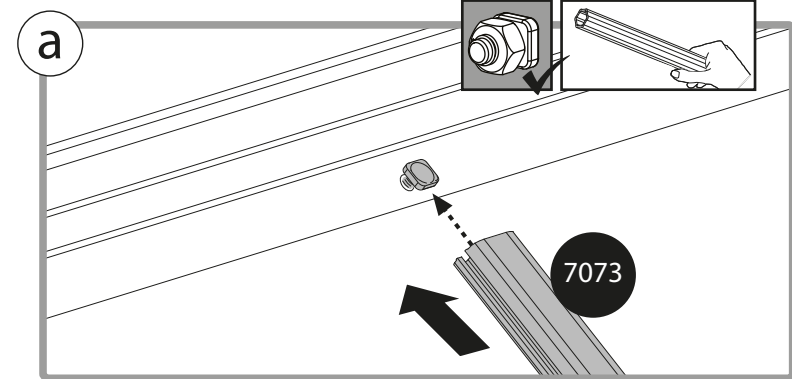
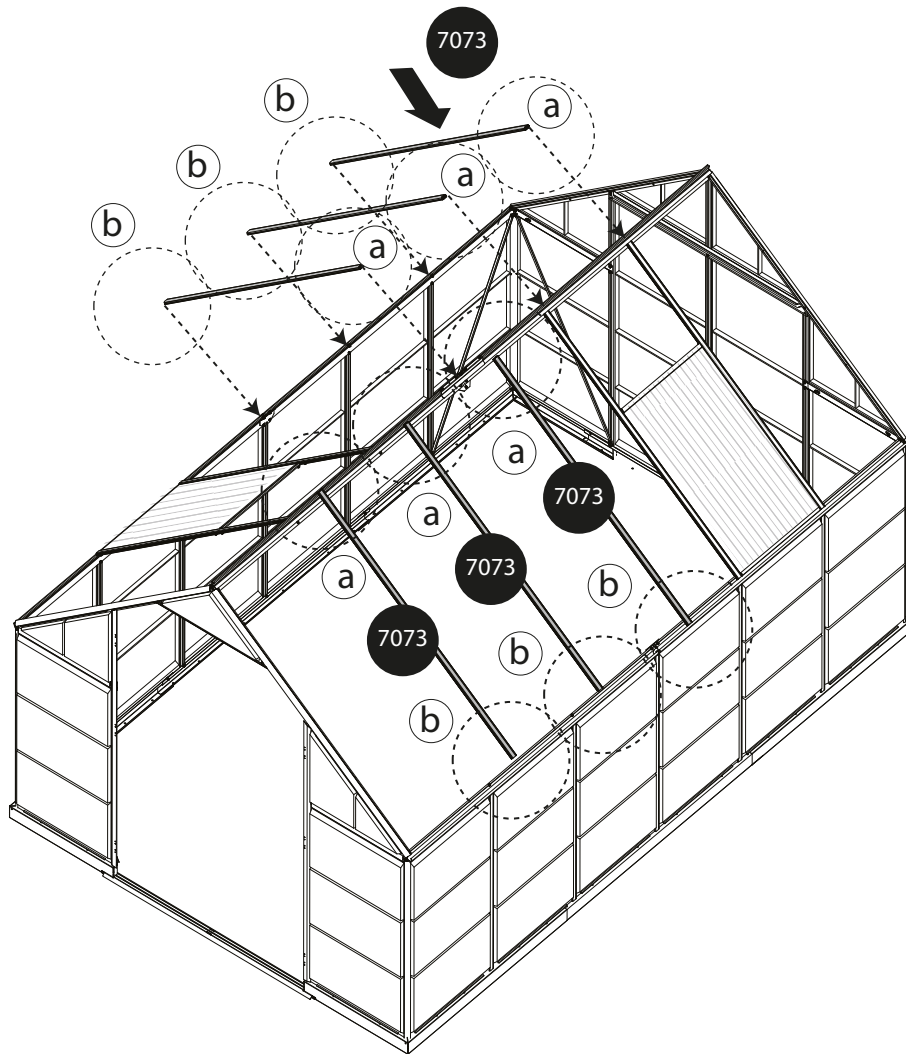

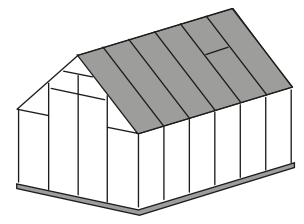

7078 x10 318 PVC x10

The left diagram shows a sheet of material (7078) with the text "This side out" repeated along its length. A profile (318 PVC) is being applied to the top edge, with an arrow pointing left and a circled 'a' indicating the direction of installation.

The right diagram shows the sheet (7078) with the profile (318 PVC) fully attached to the top edge. An arrow points left from the profile, and a circled 'a' is at the top left corner, indicating the installation direction.

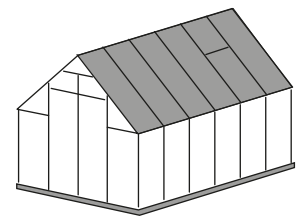

7078 + 318 PVC

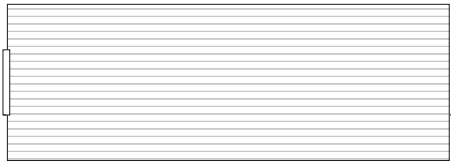

x1

981

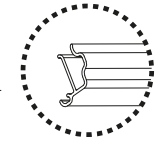

x1

a

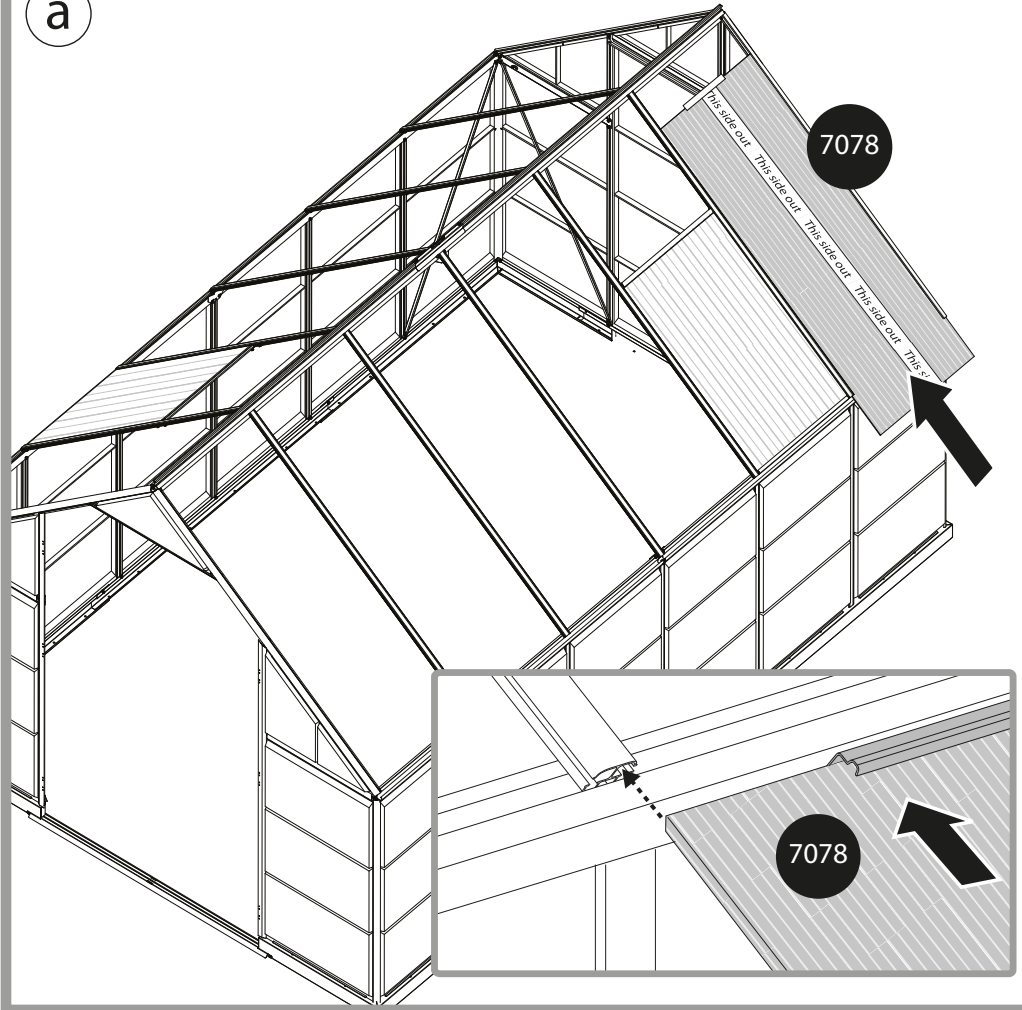

b

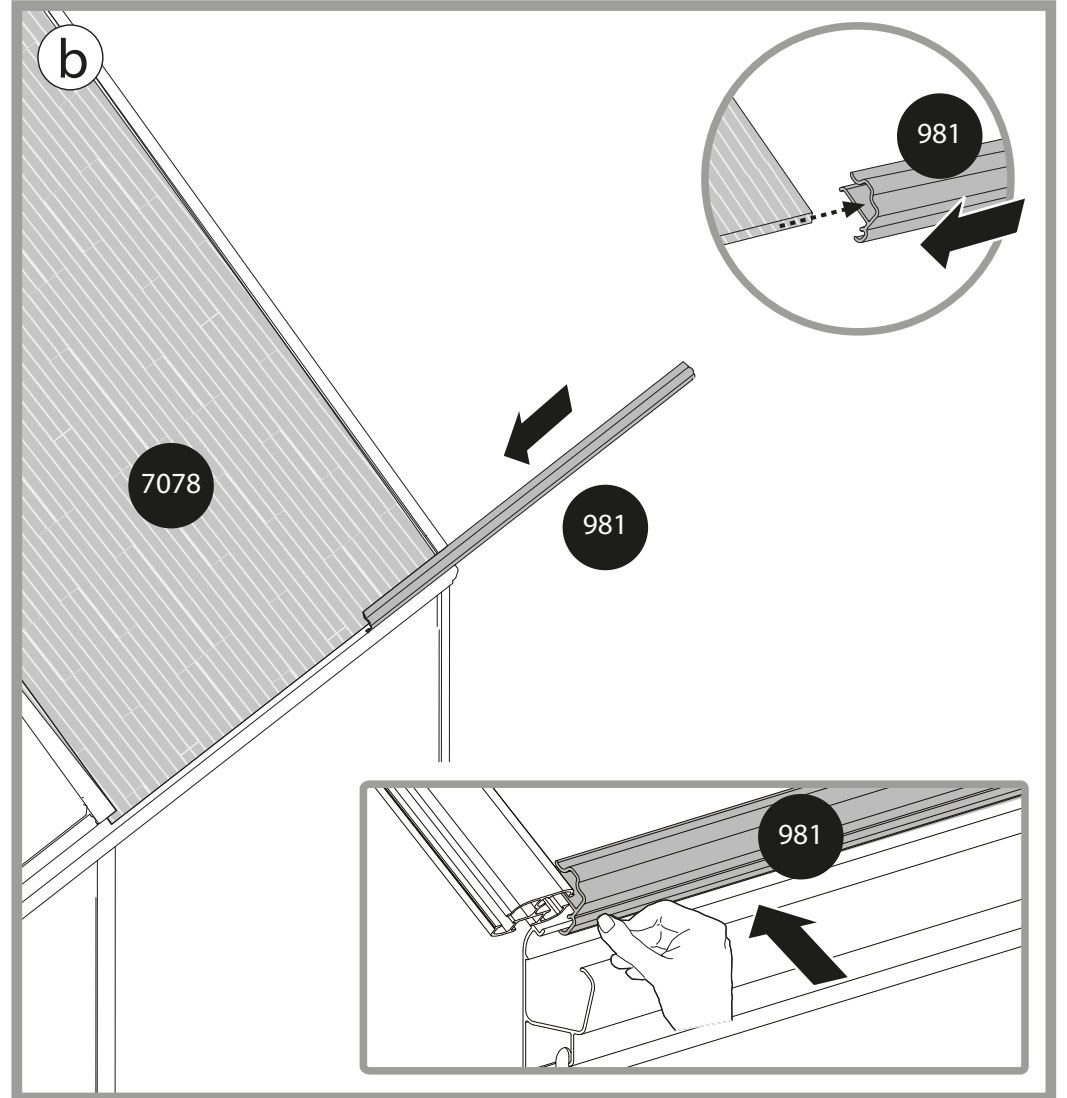

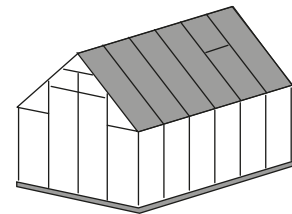

7078 + 318 PVC



x9

981

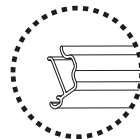

x9

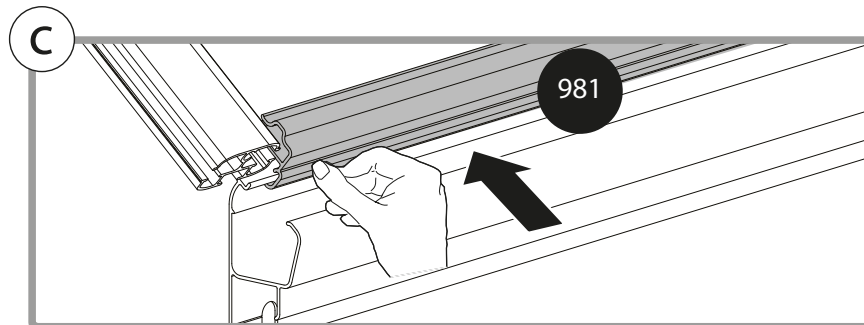
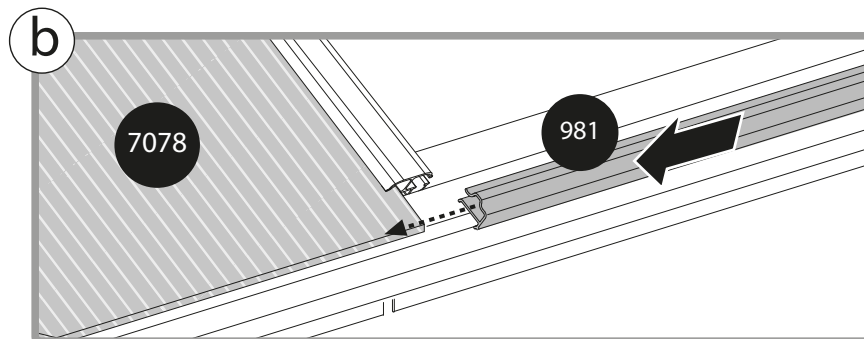
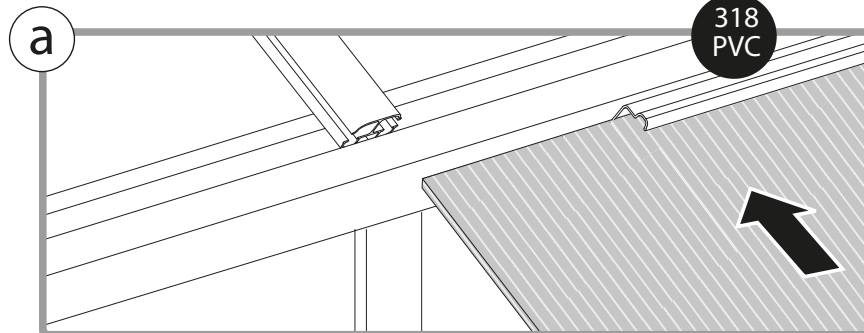
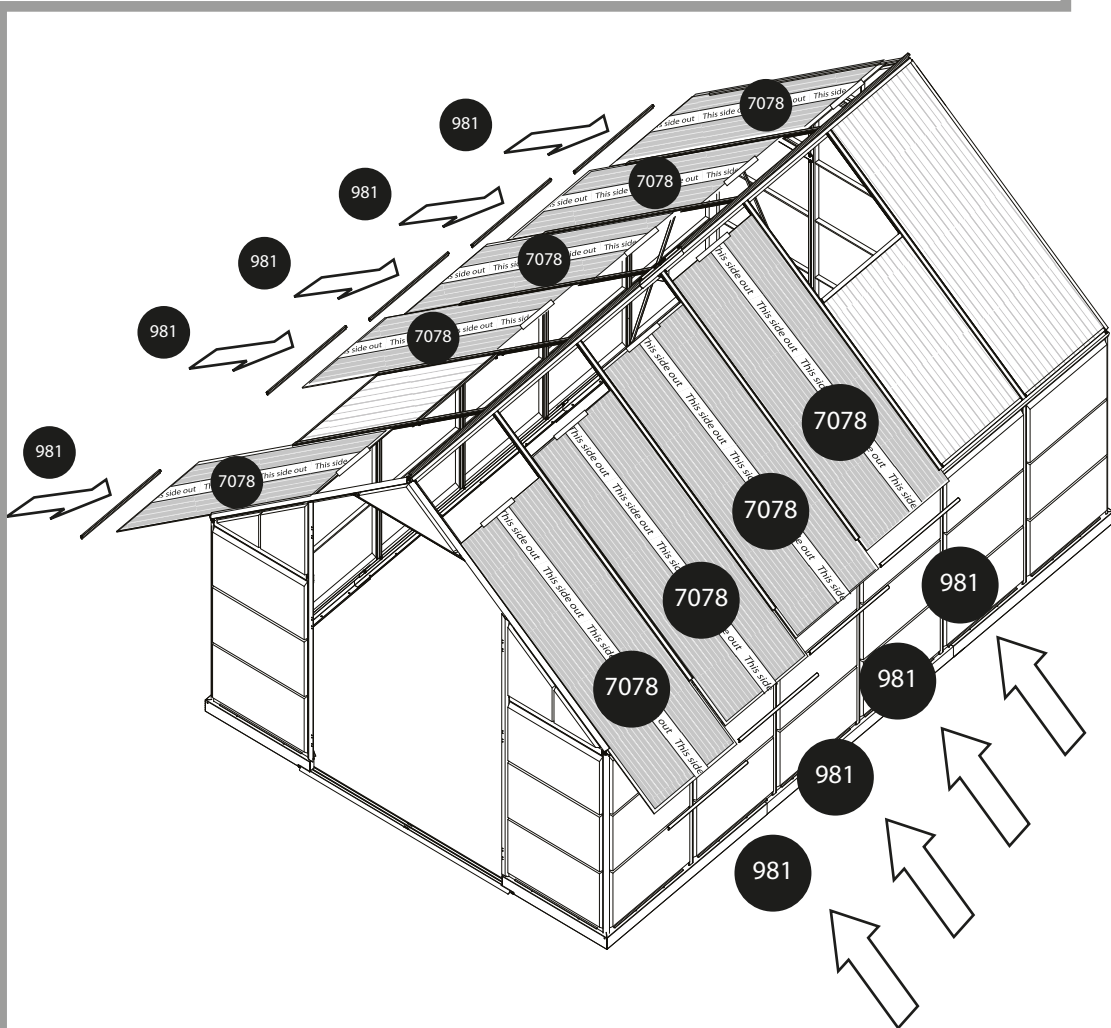

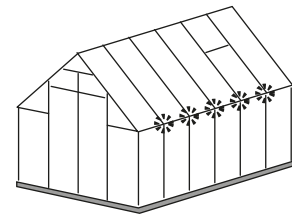

329

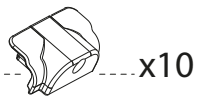

4043

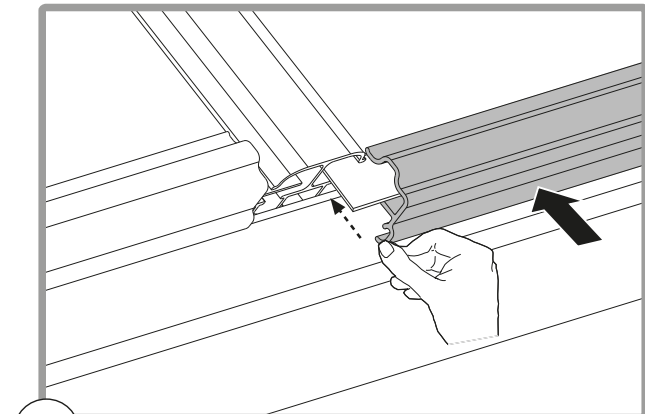
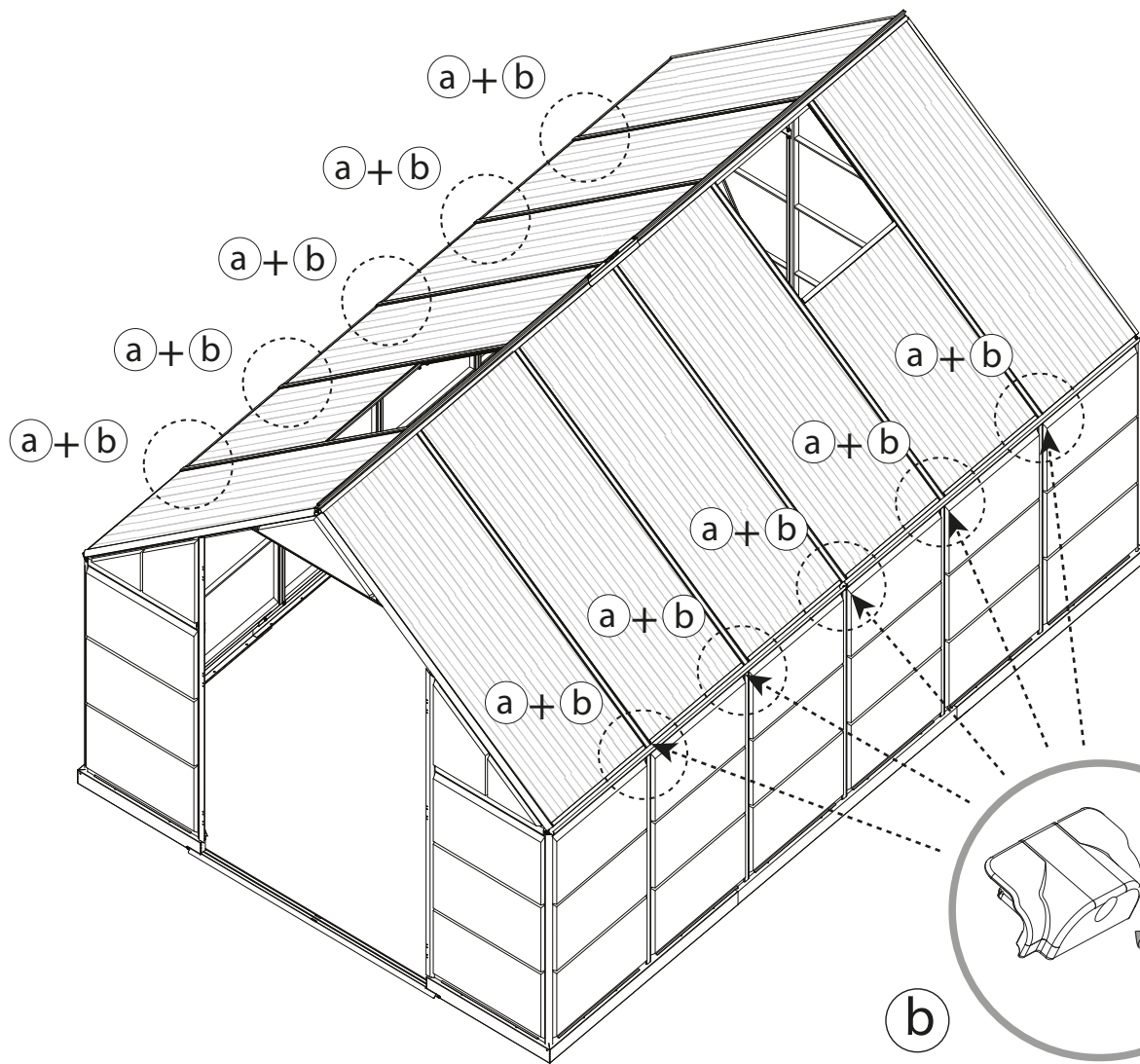

a

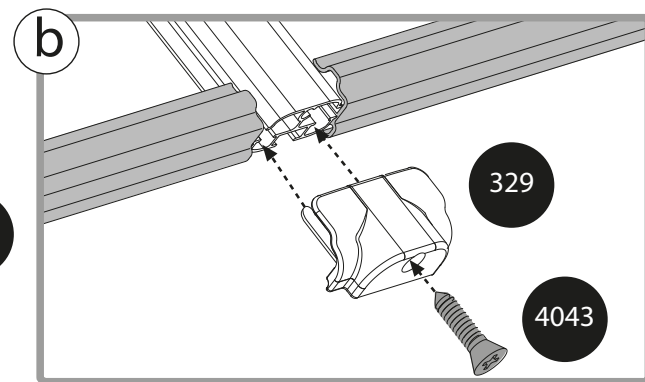
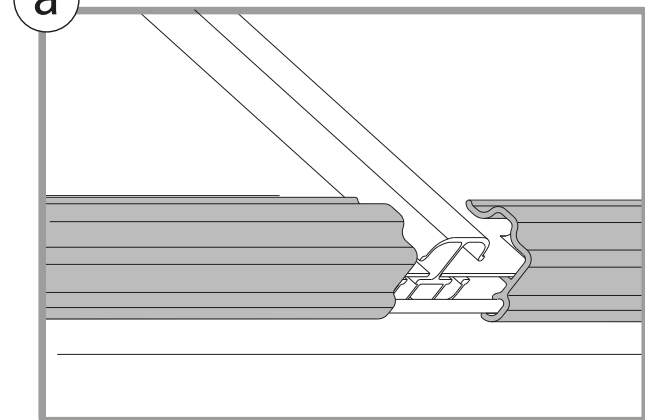

b

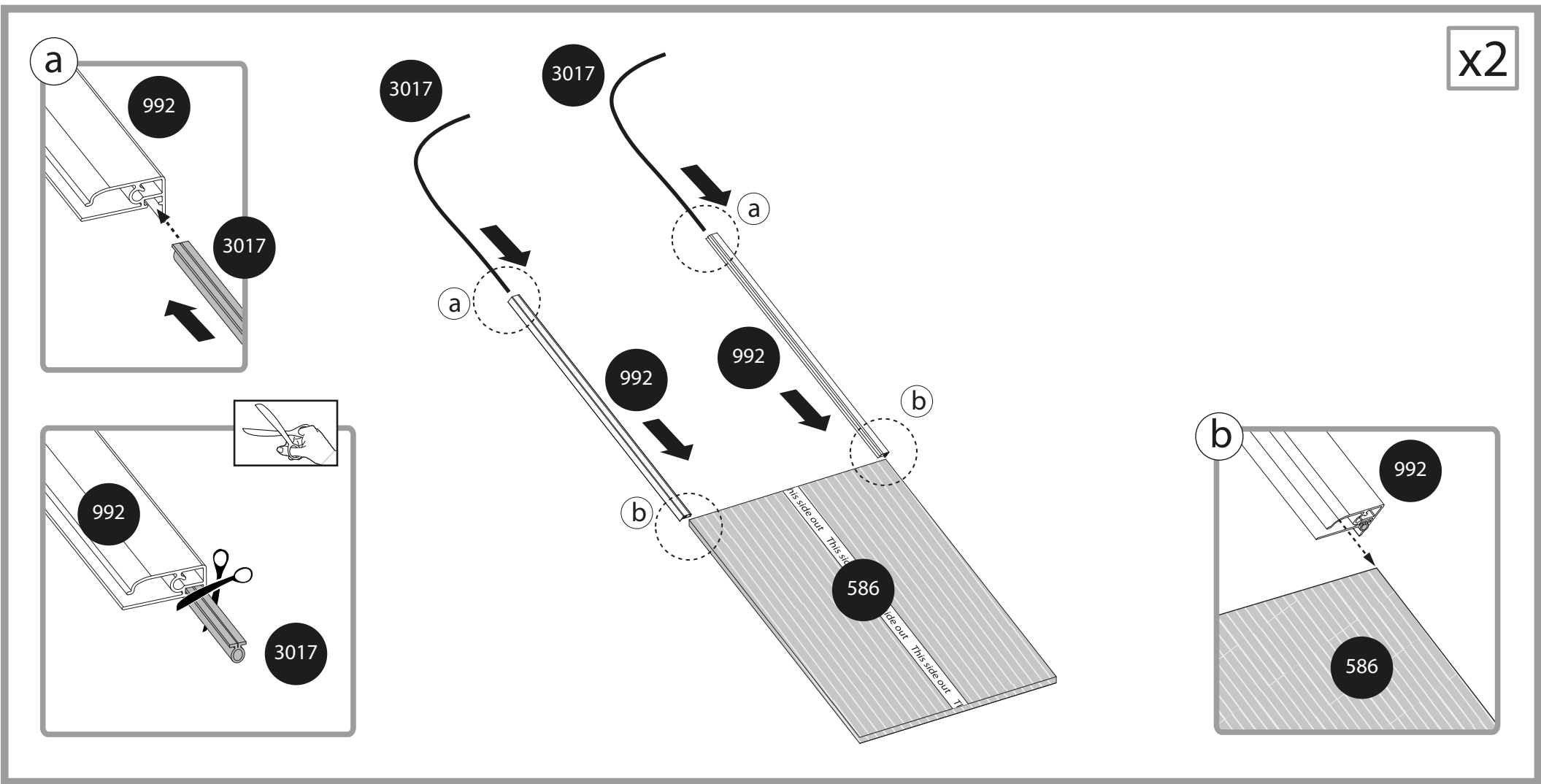
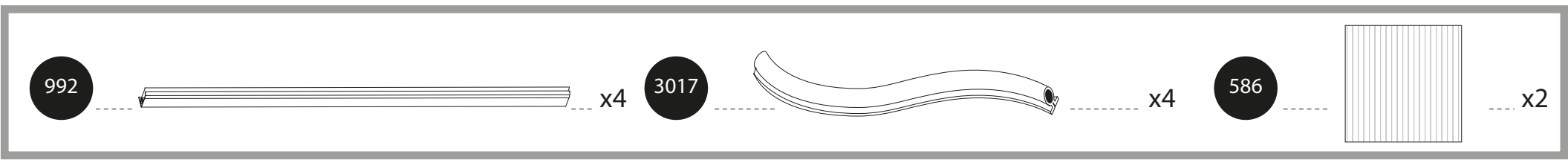
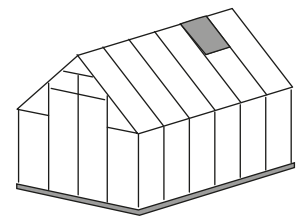

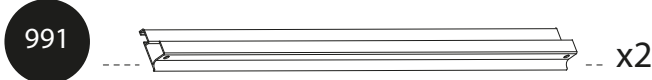
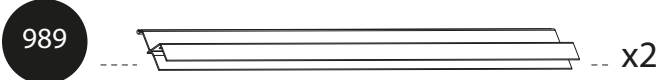
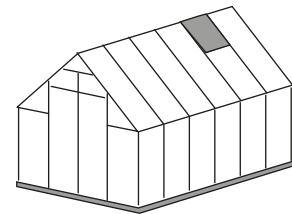

x2

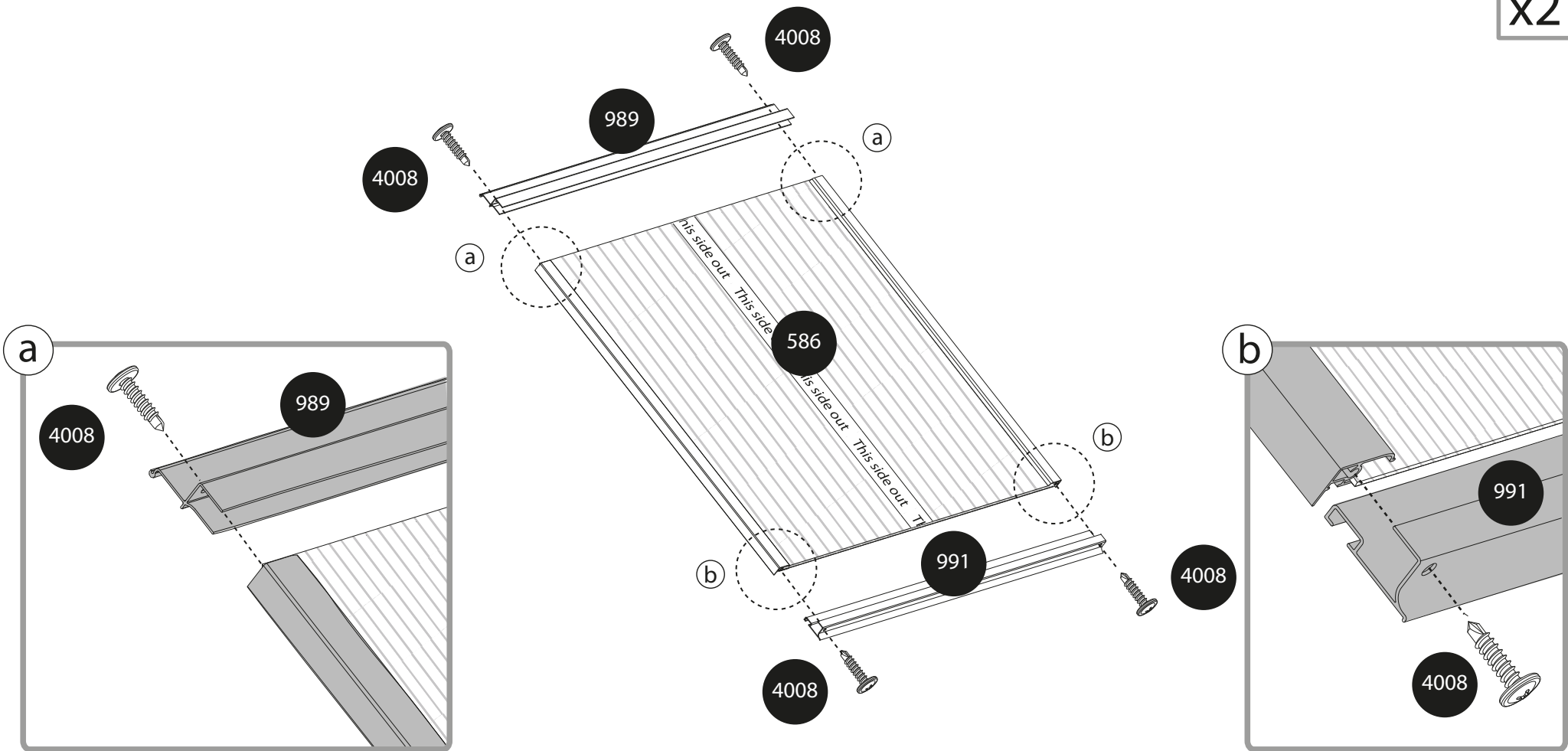

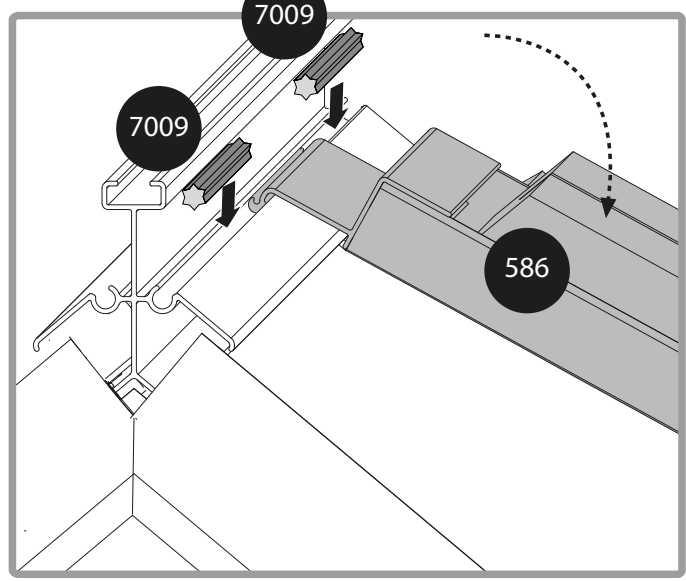
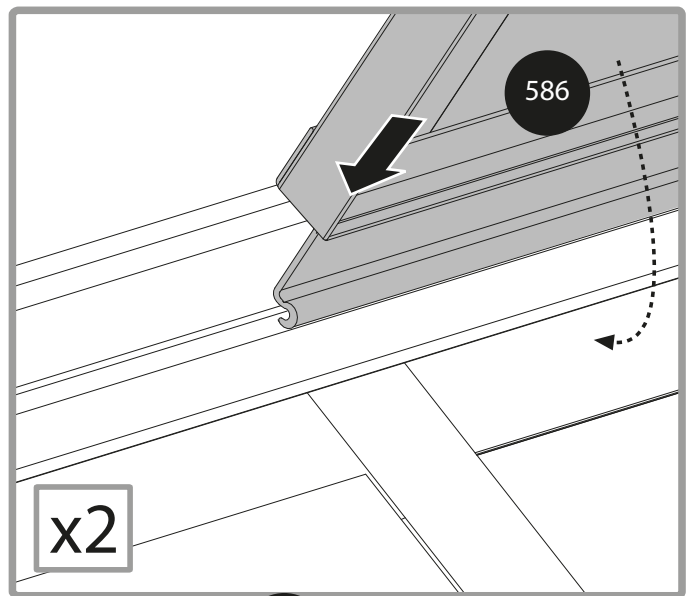
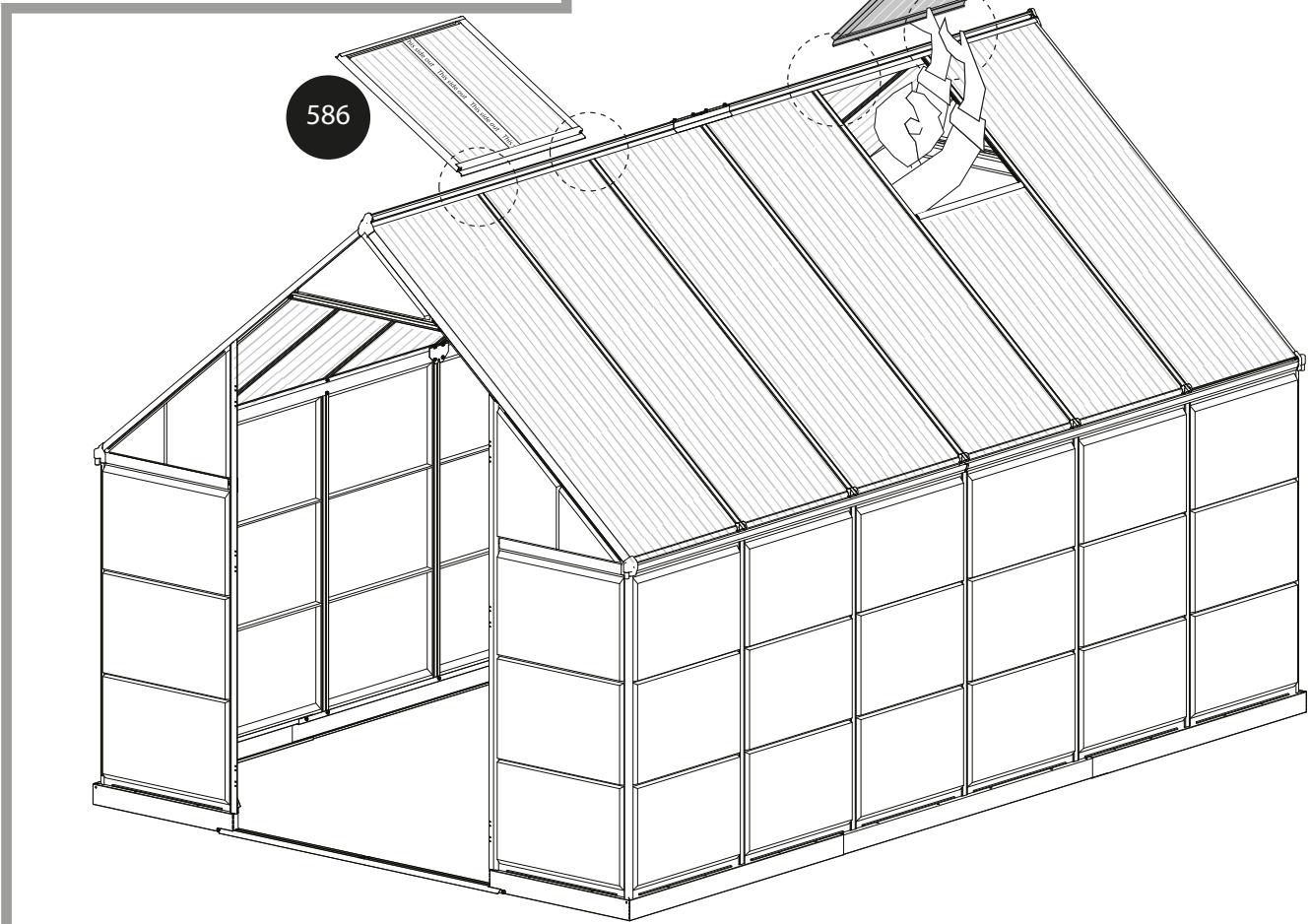
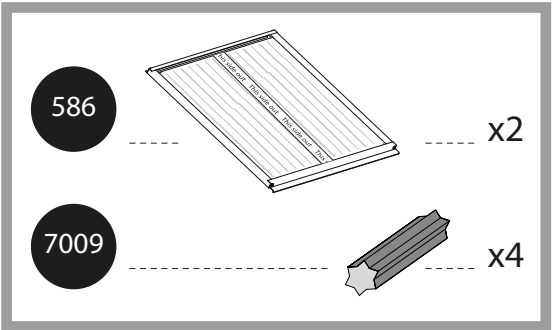
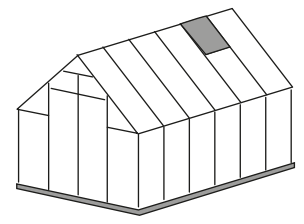

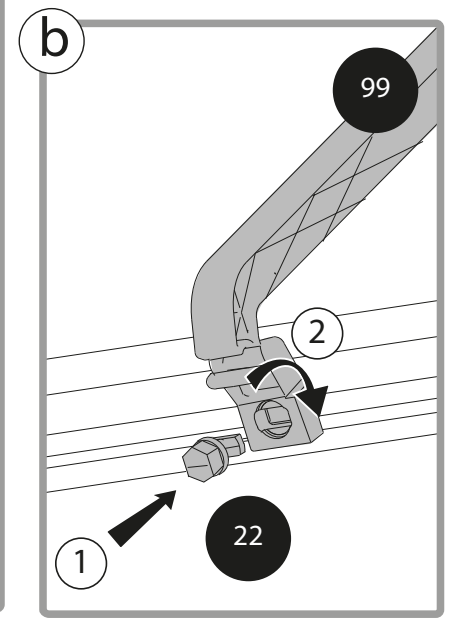
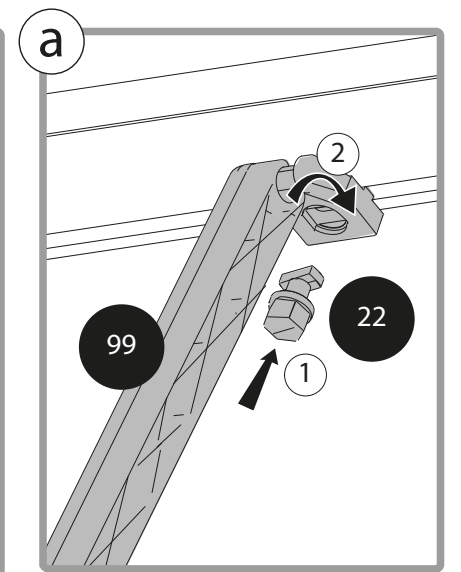
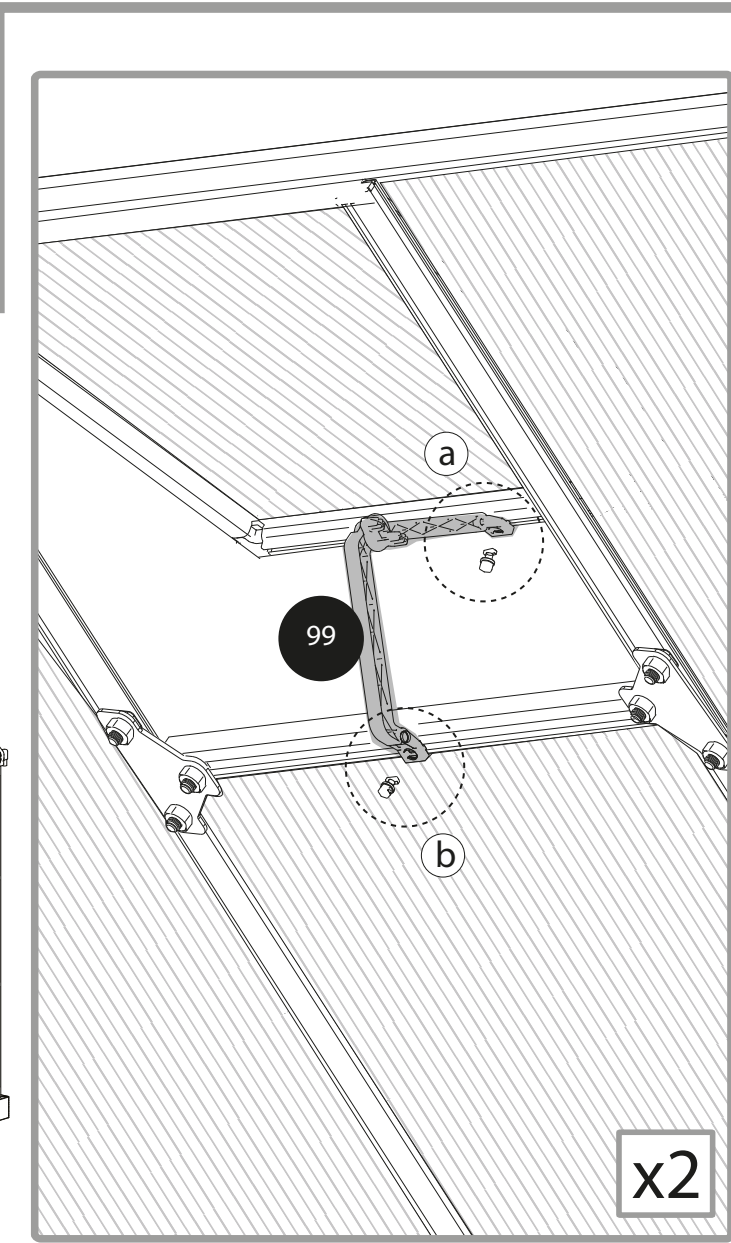
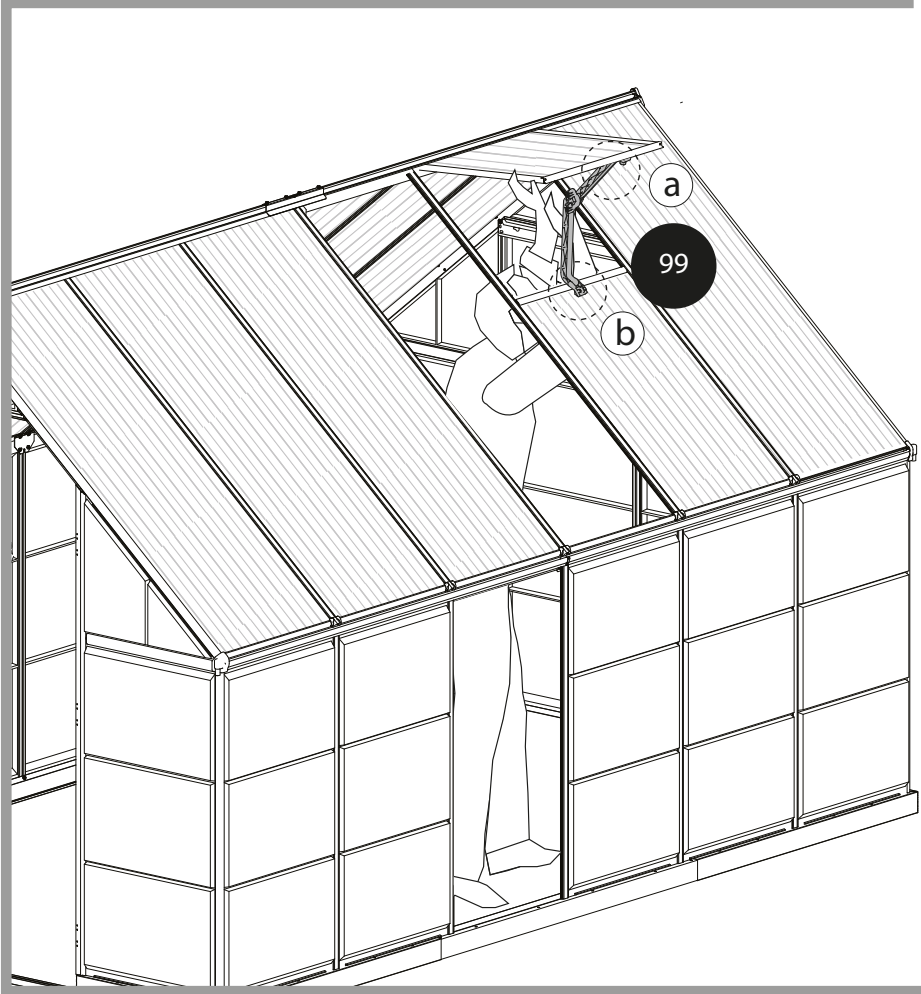
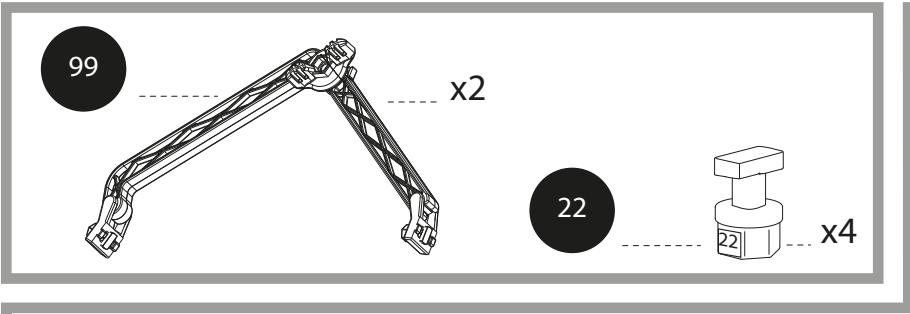
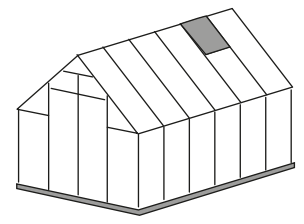

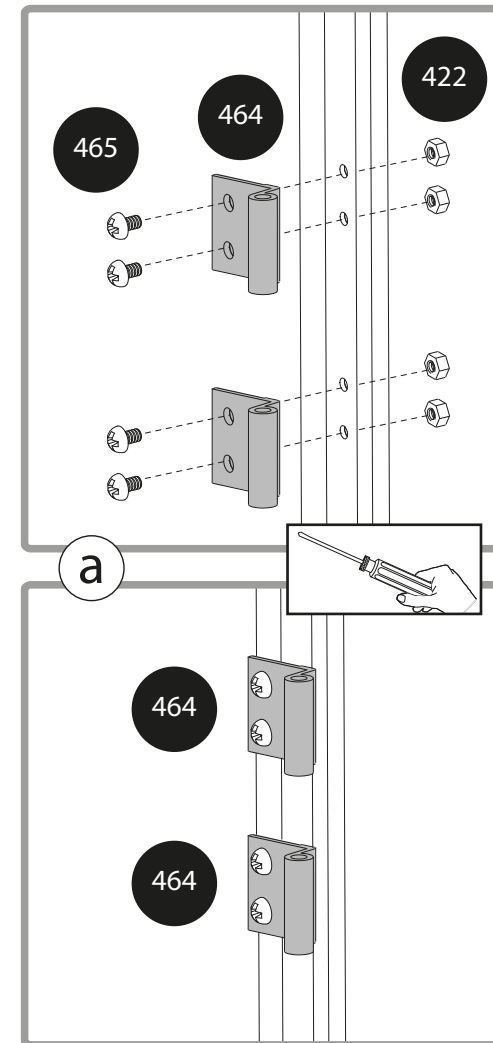
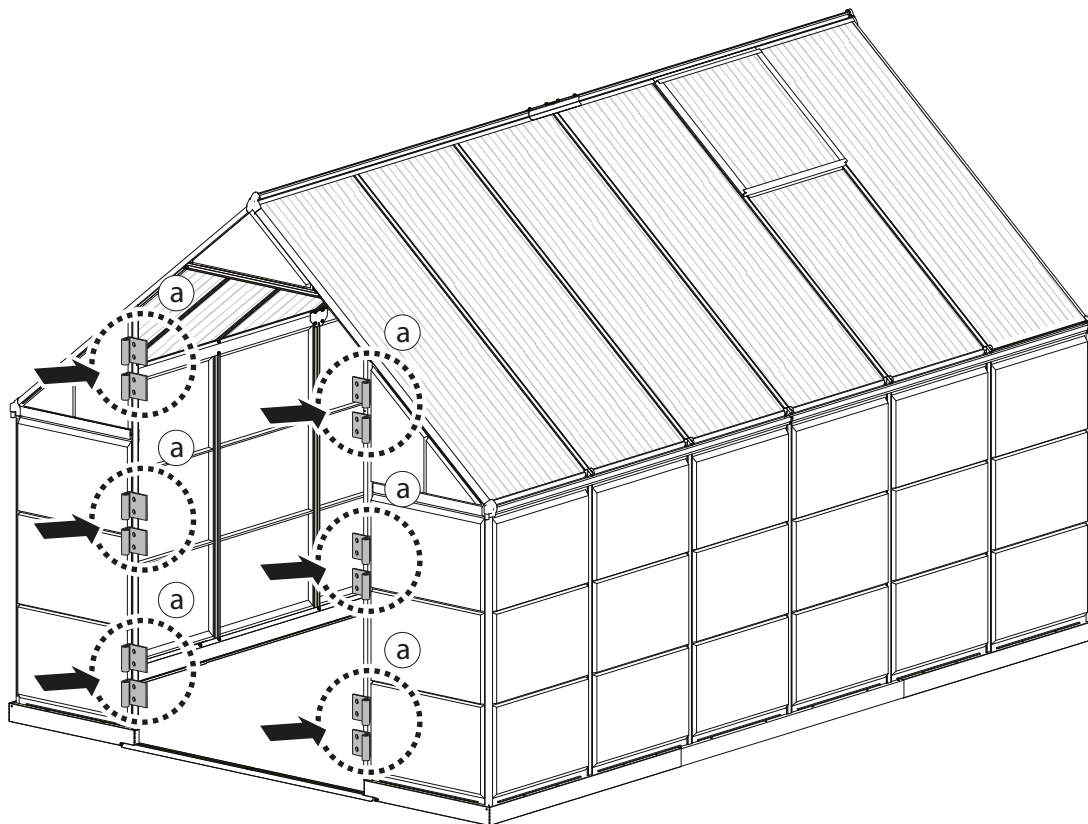
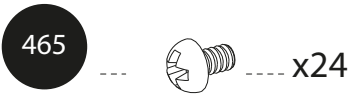
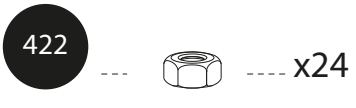
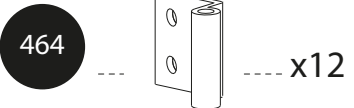
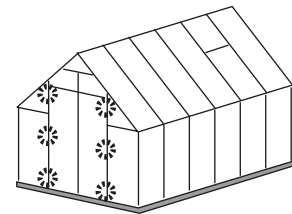

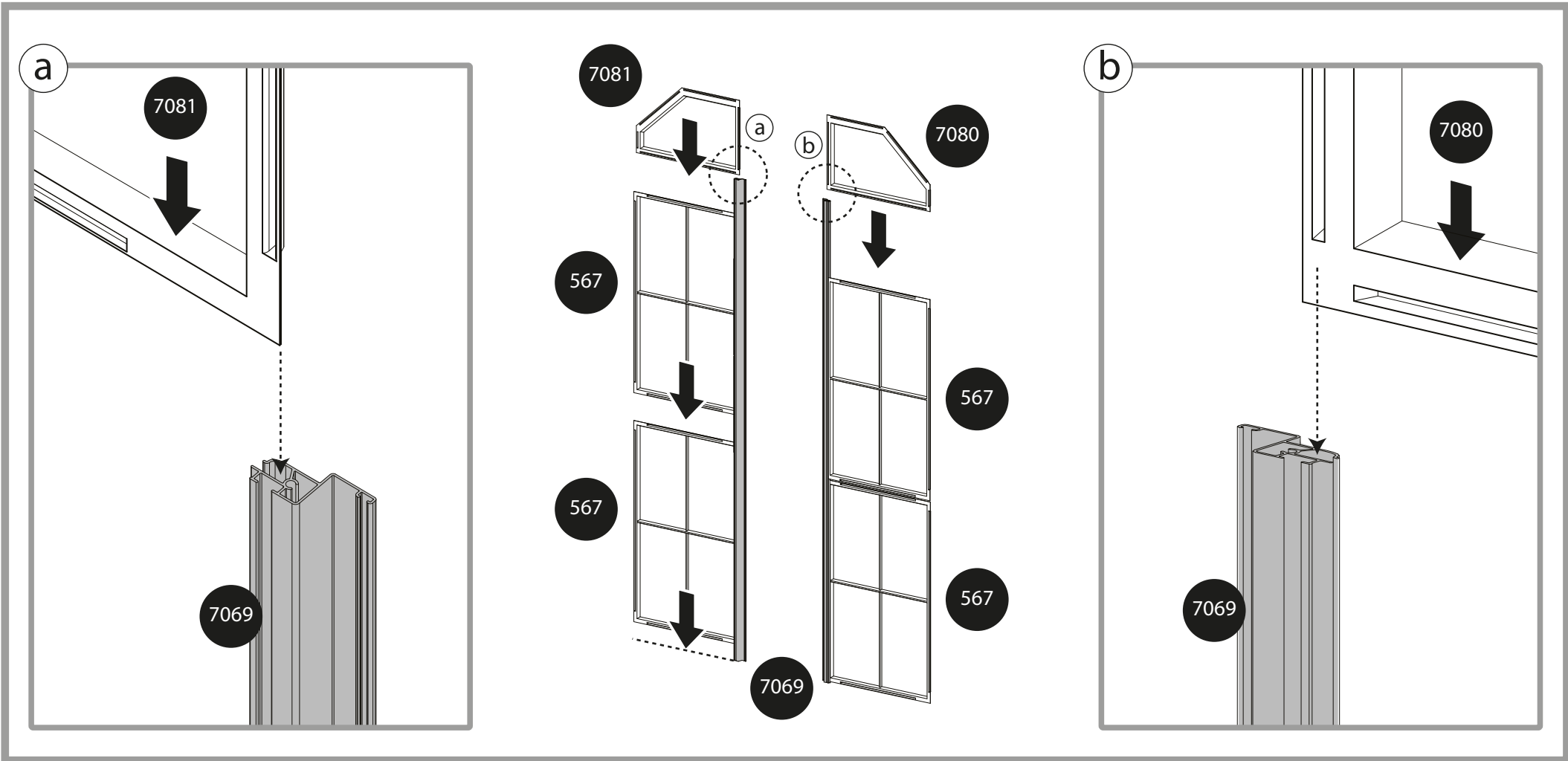
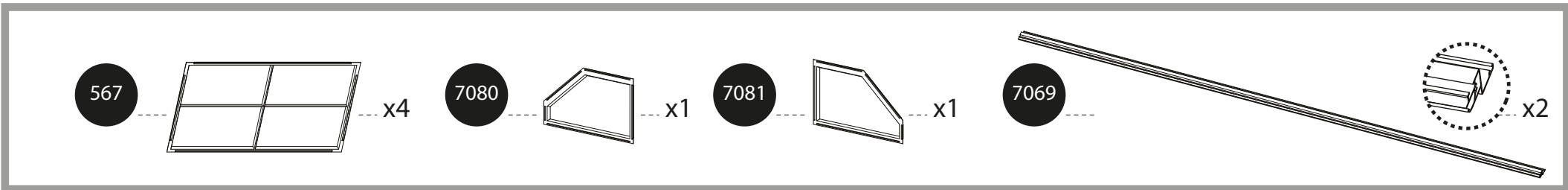
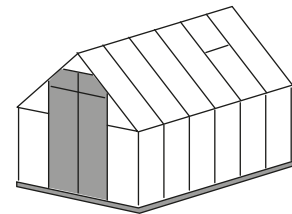

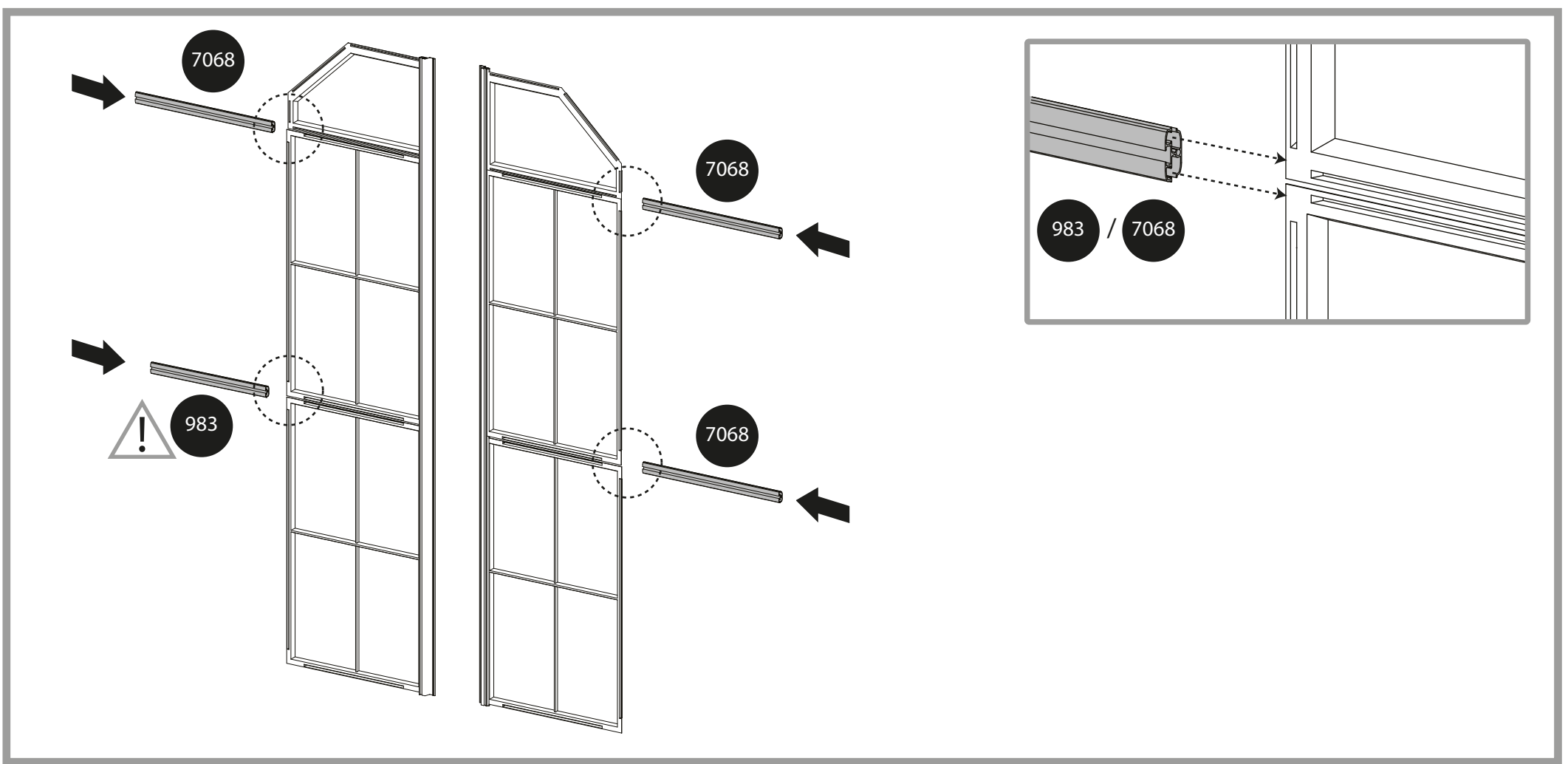
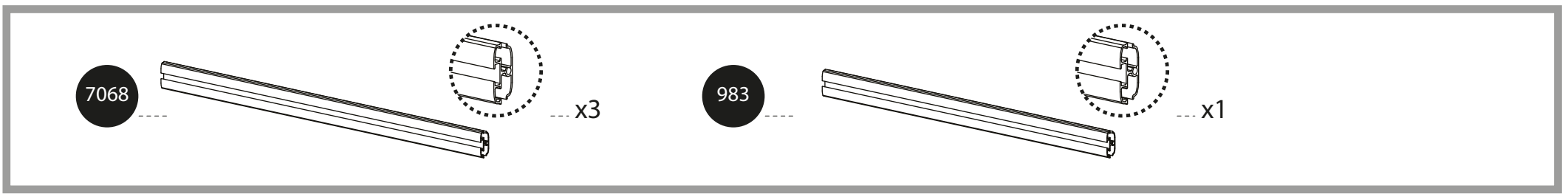
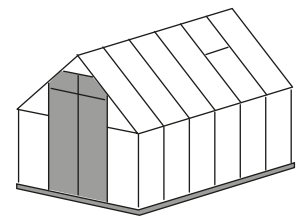

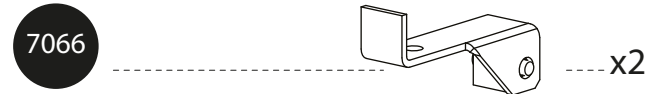
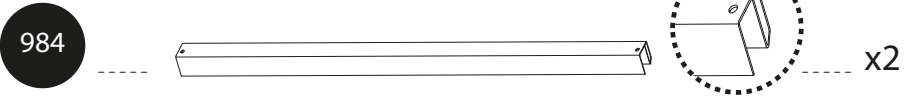
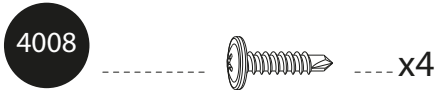
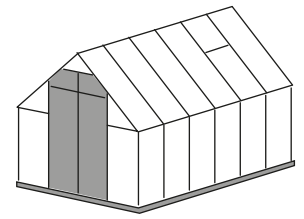

x2

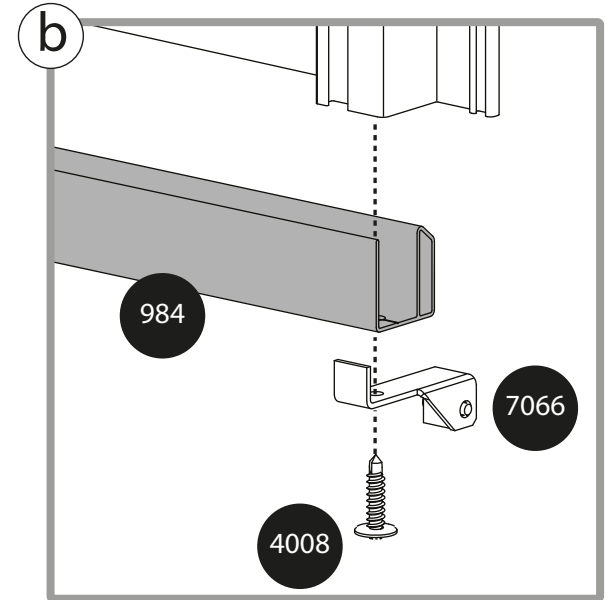
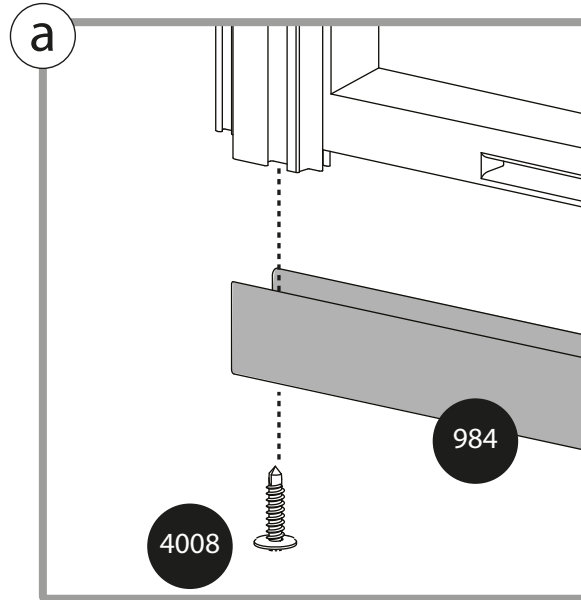
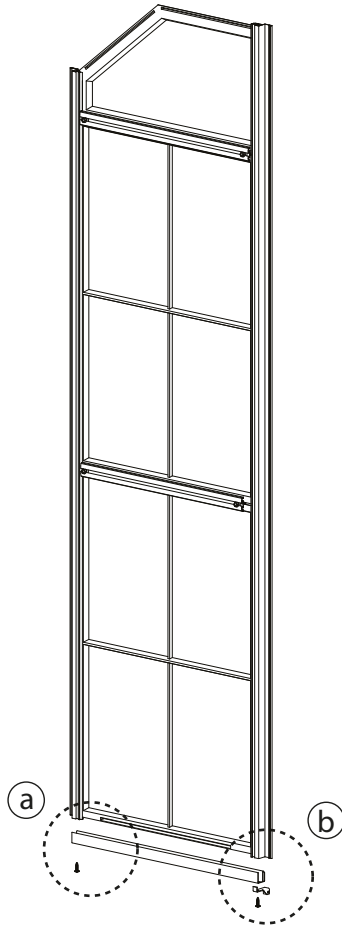

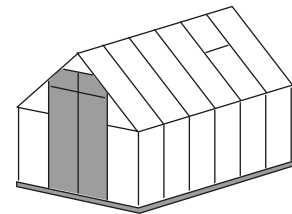

411



x31

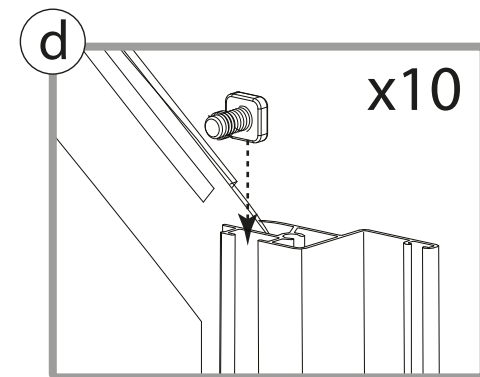
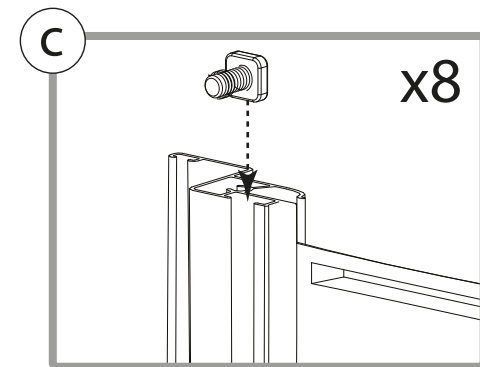
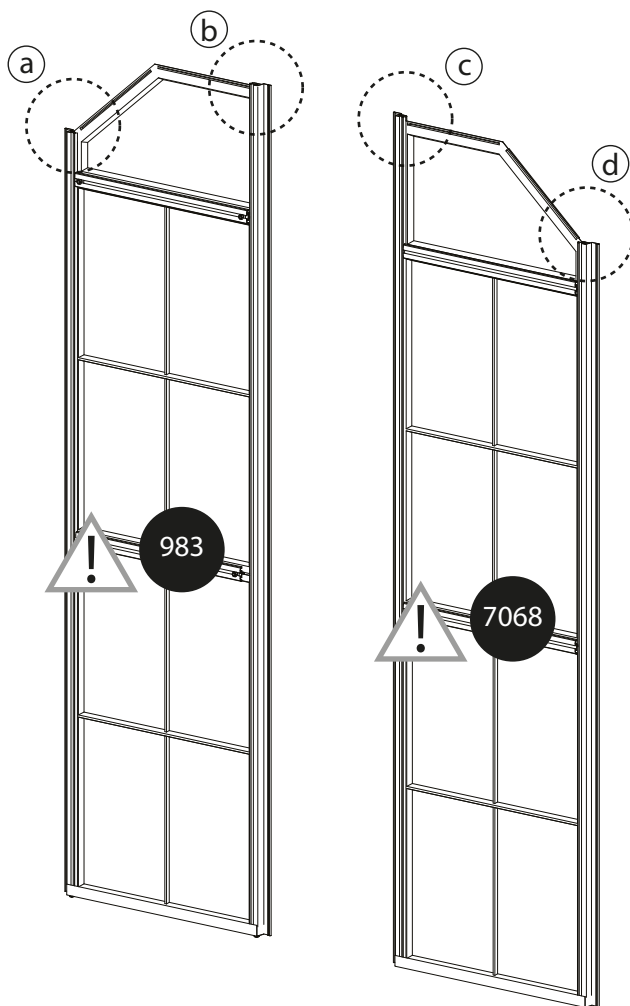
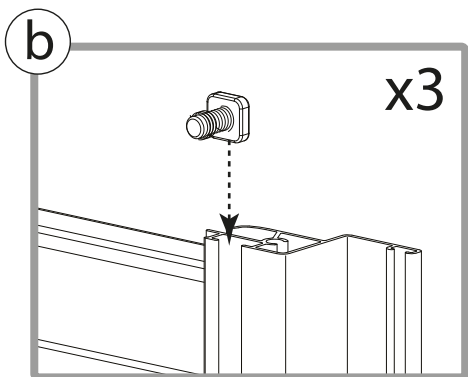
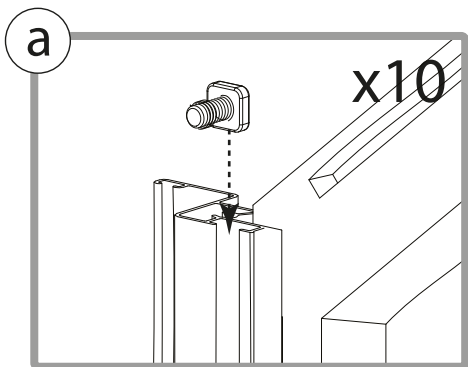

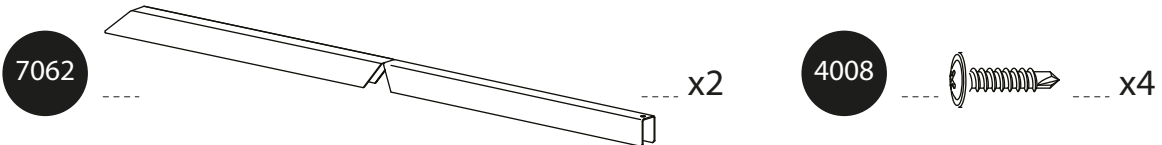
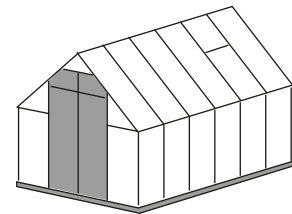

x2

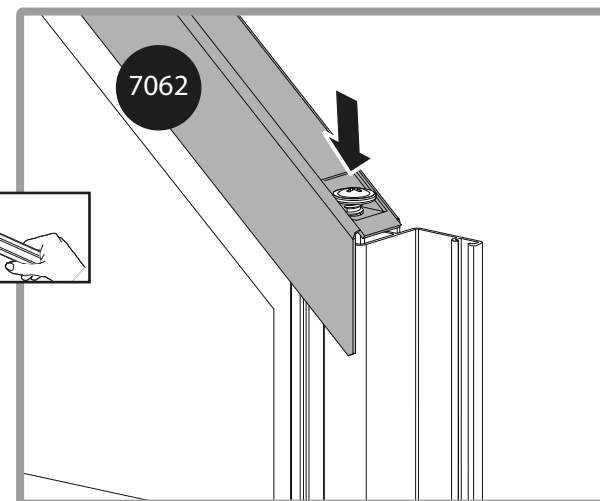
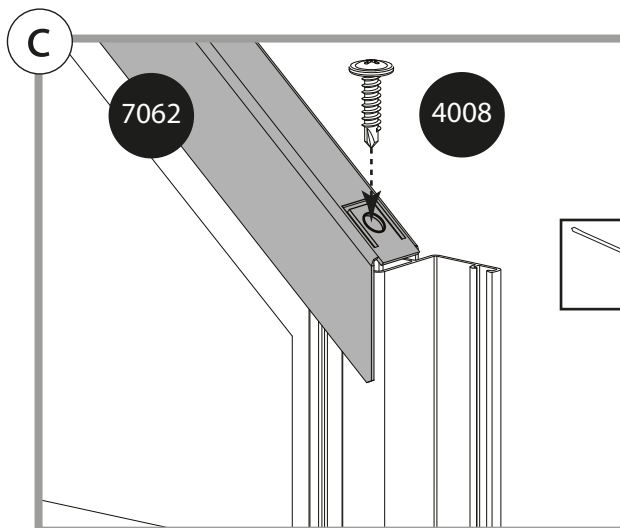
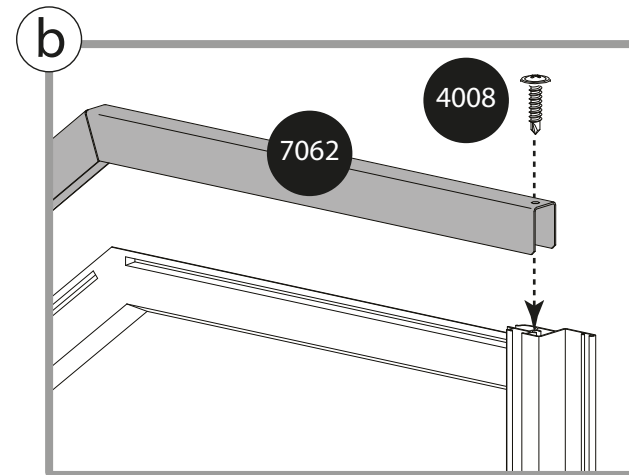
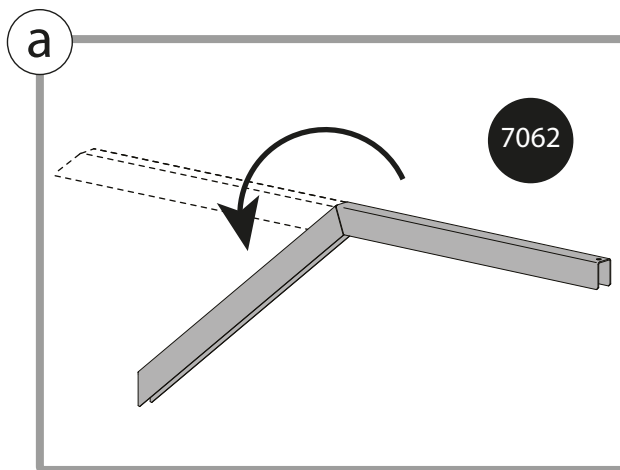
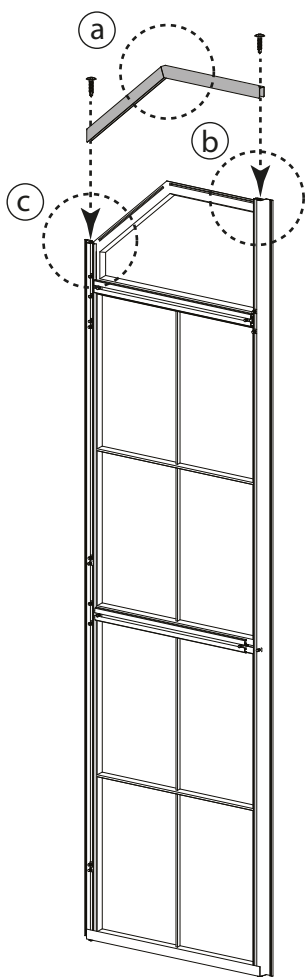

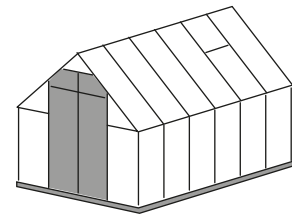

7065

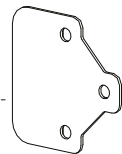

x1

288

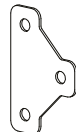

x6

412



x21

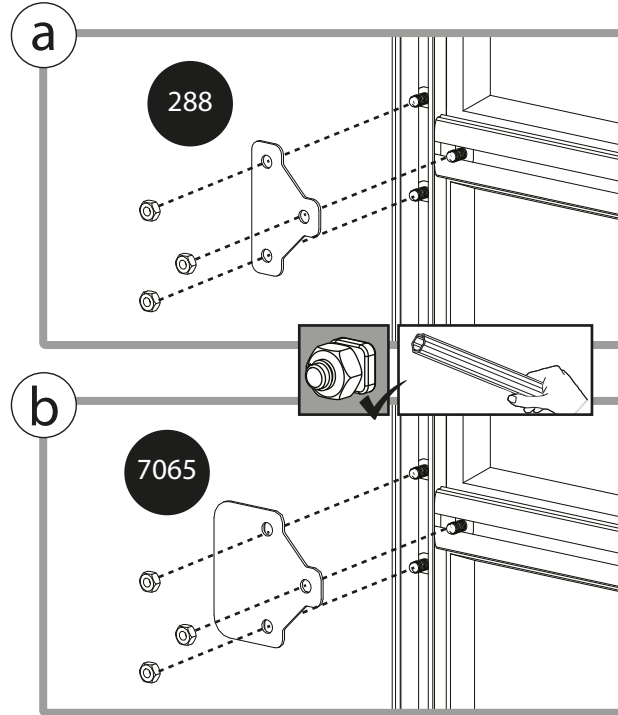
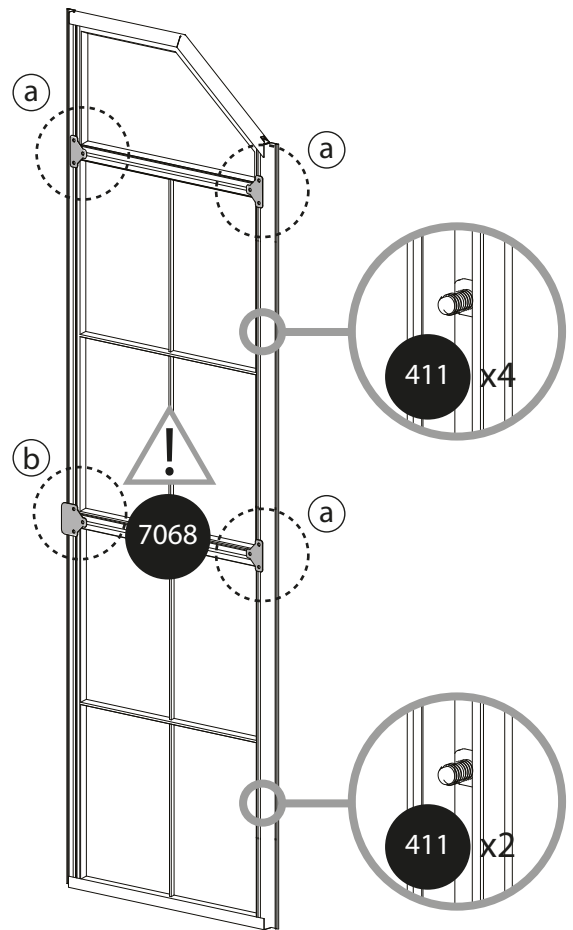
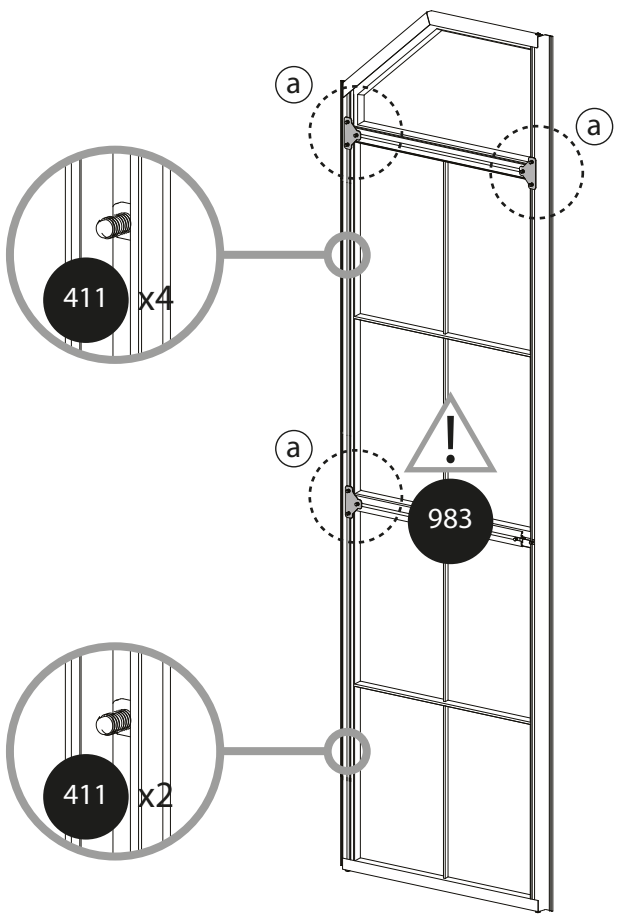

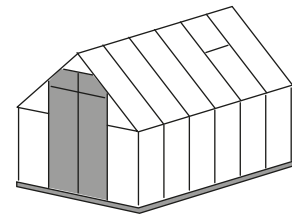

462



x6

412



x12

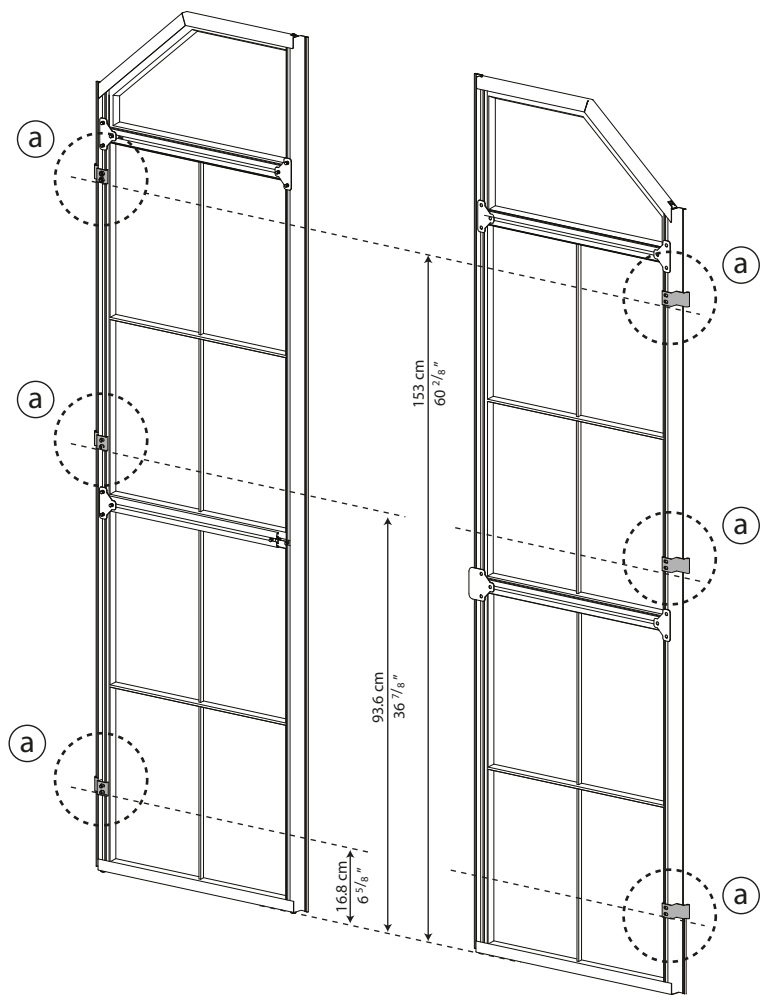

a

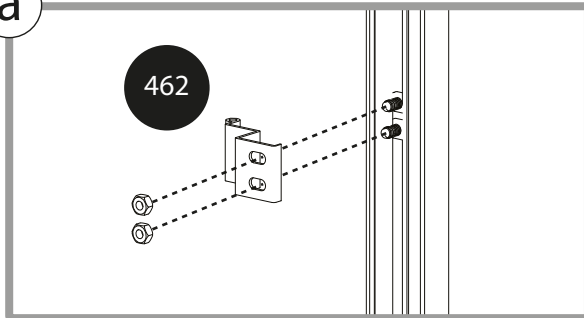

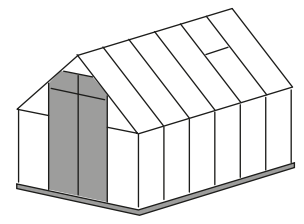

7086 x1

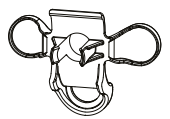

7085 x1

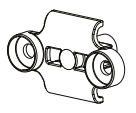

7084 x1

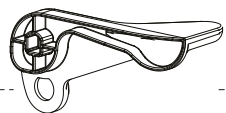

7083 x1

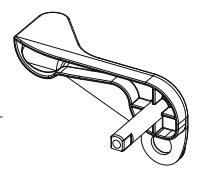

7088 x1
M4 x 50mm

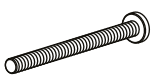

423 x1



412 x2

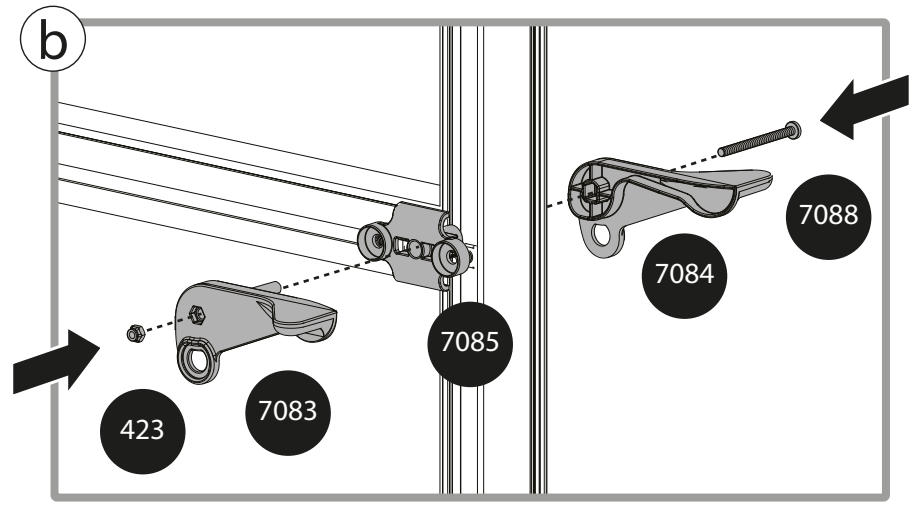
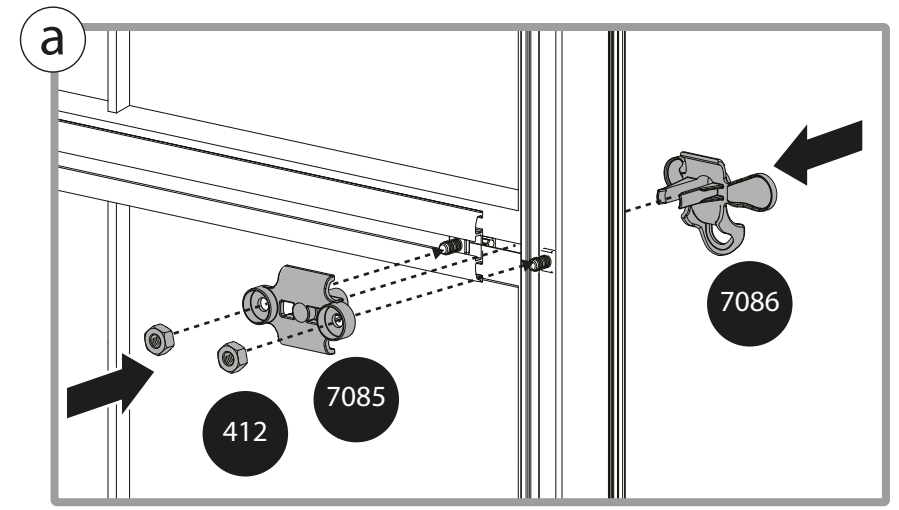
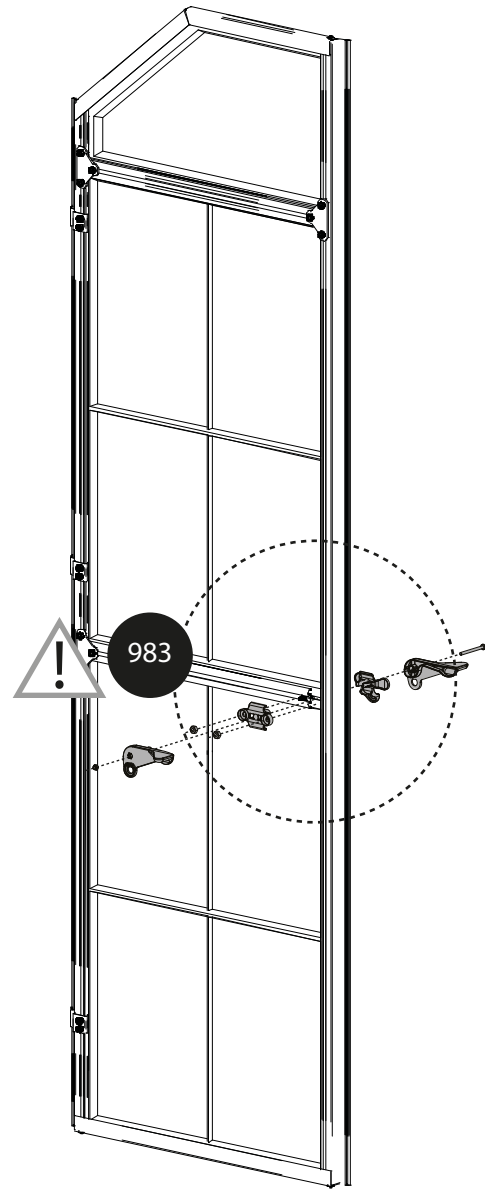

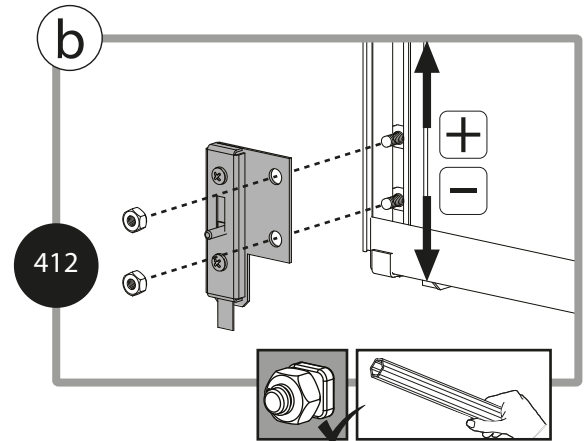
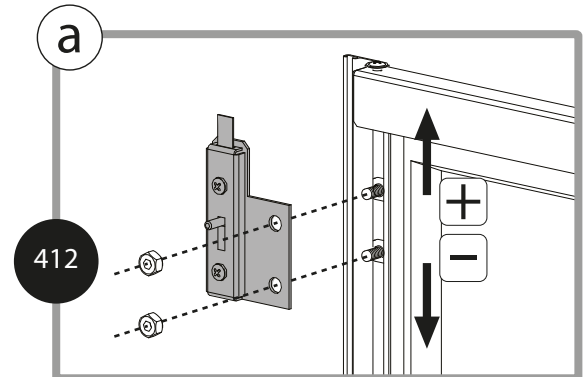
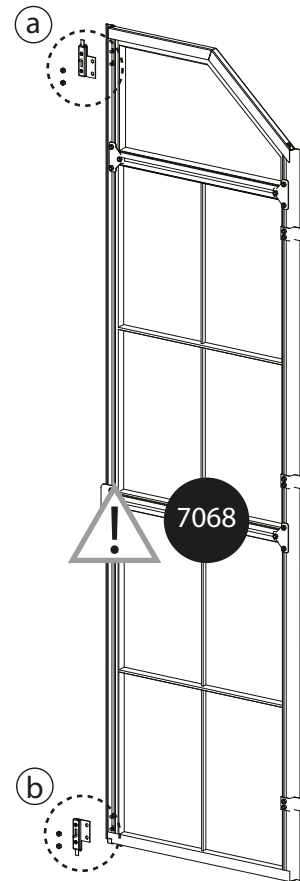
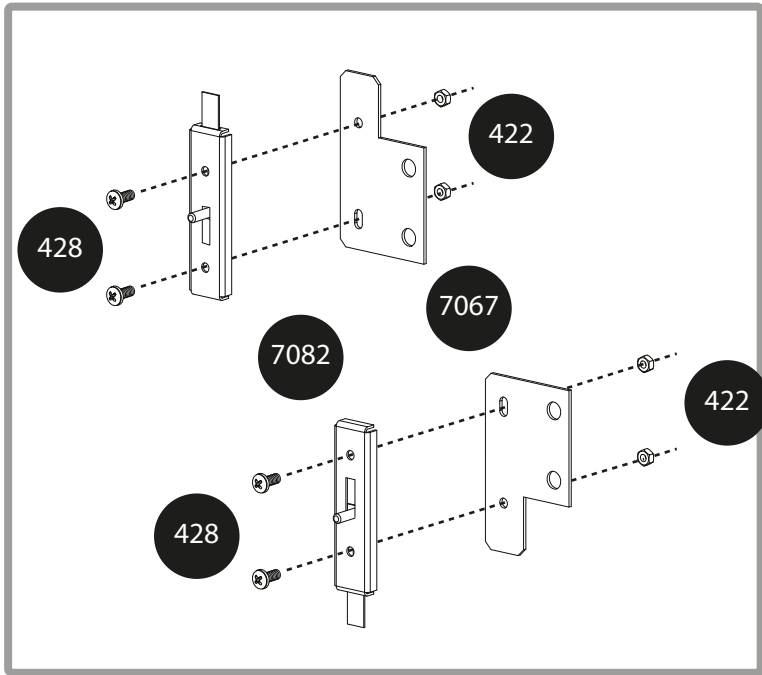
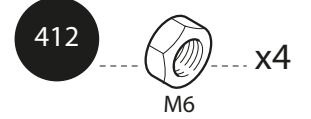
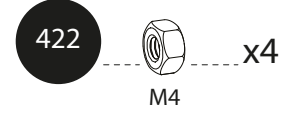
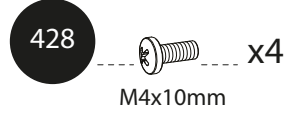
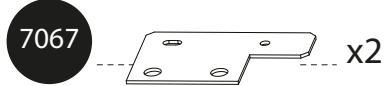
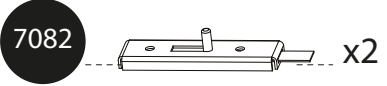
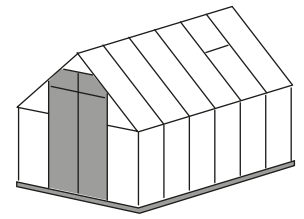

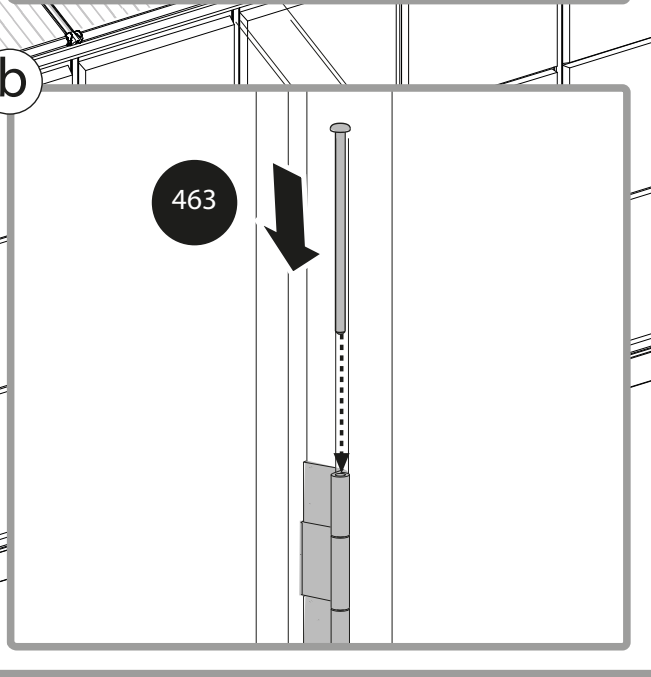
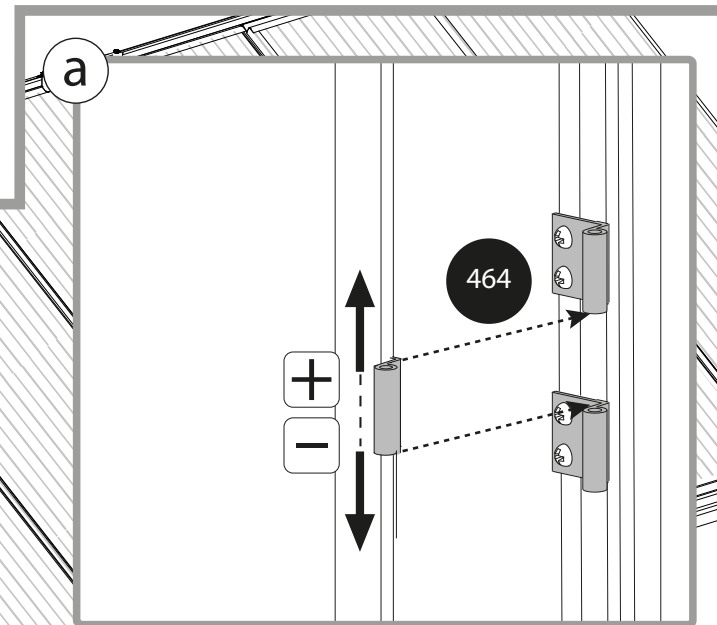
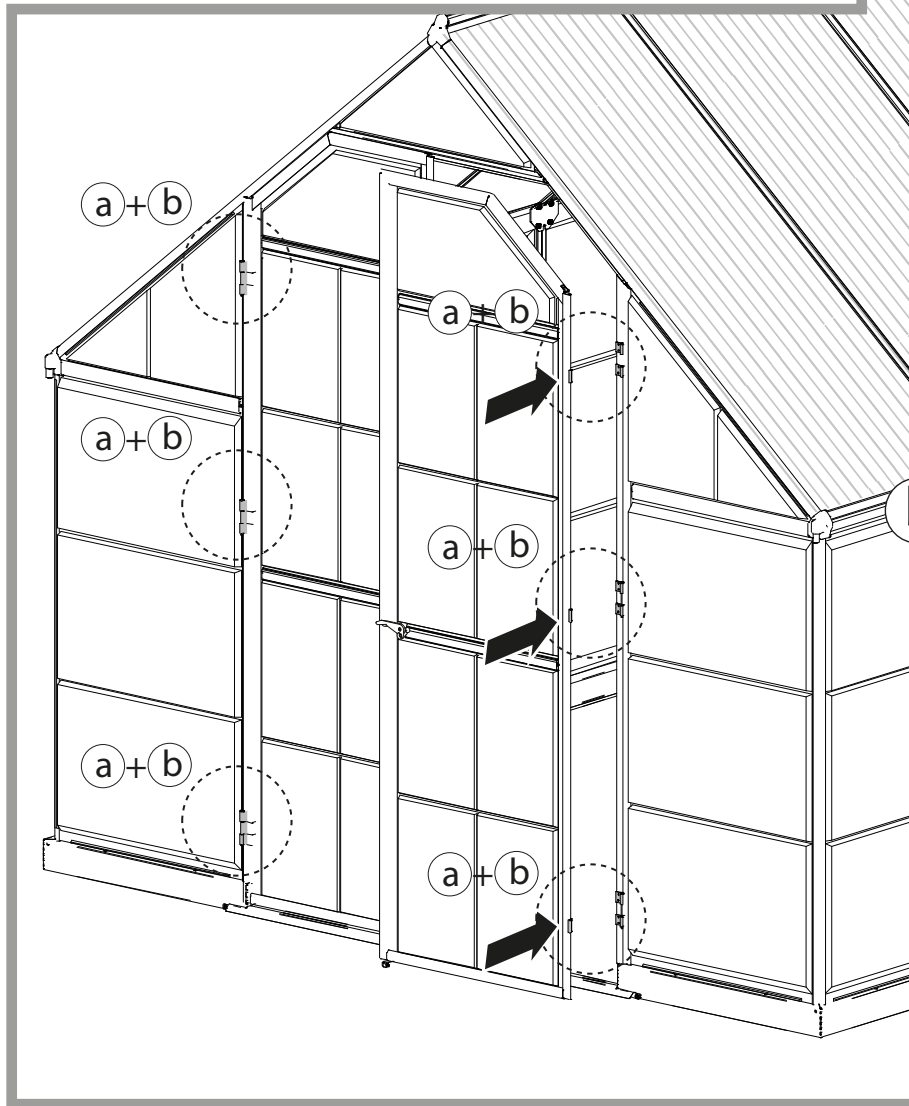
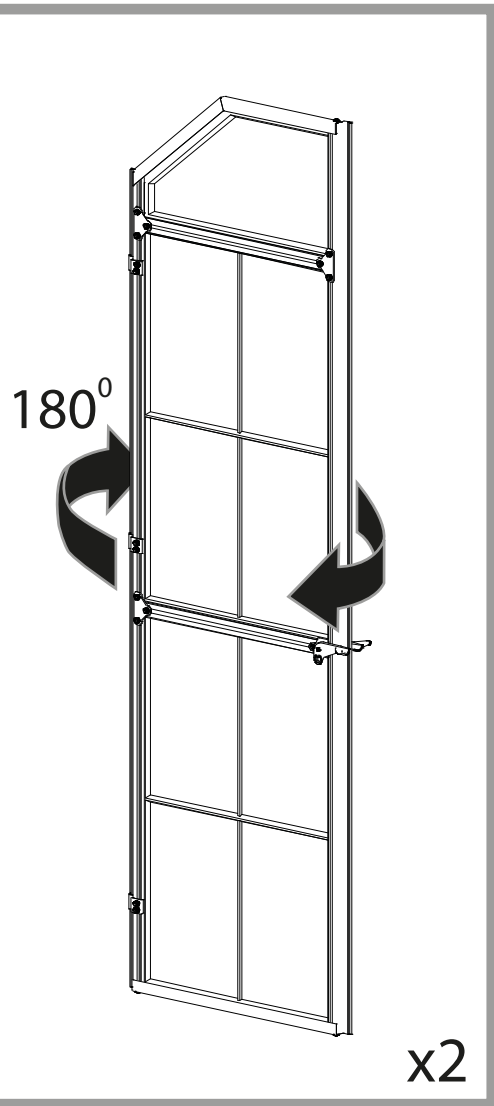
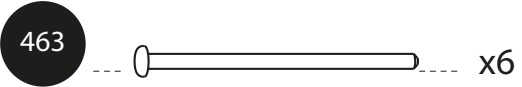
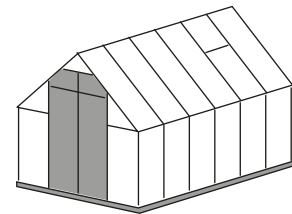

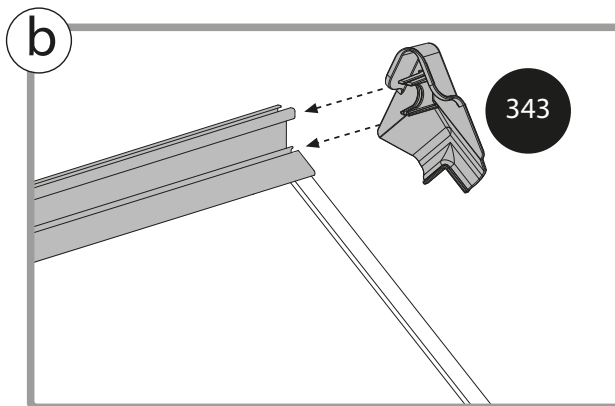
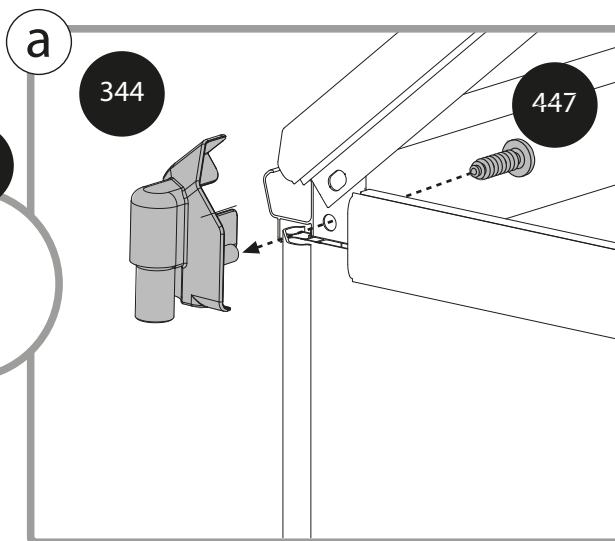
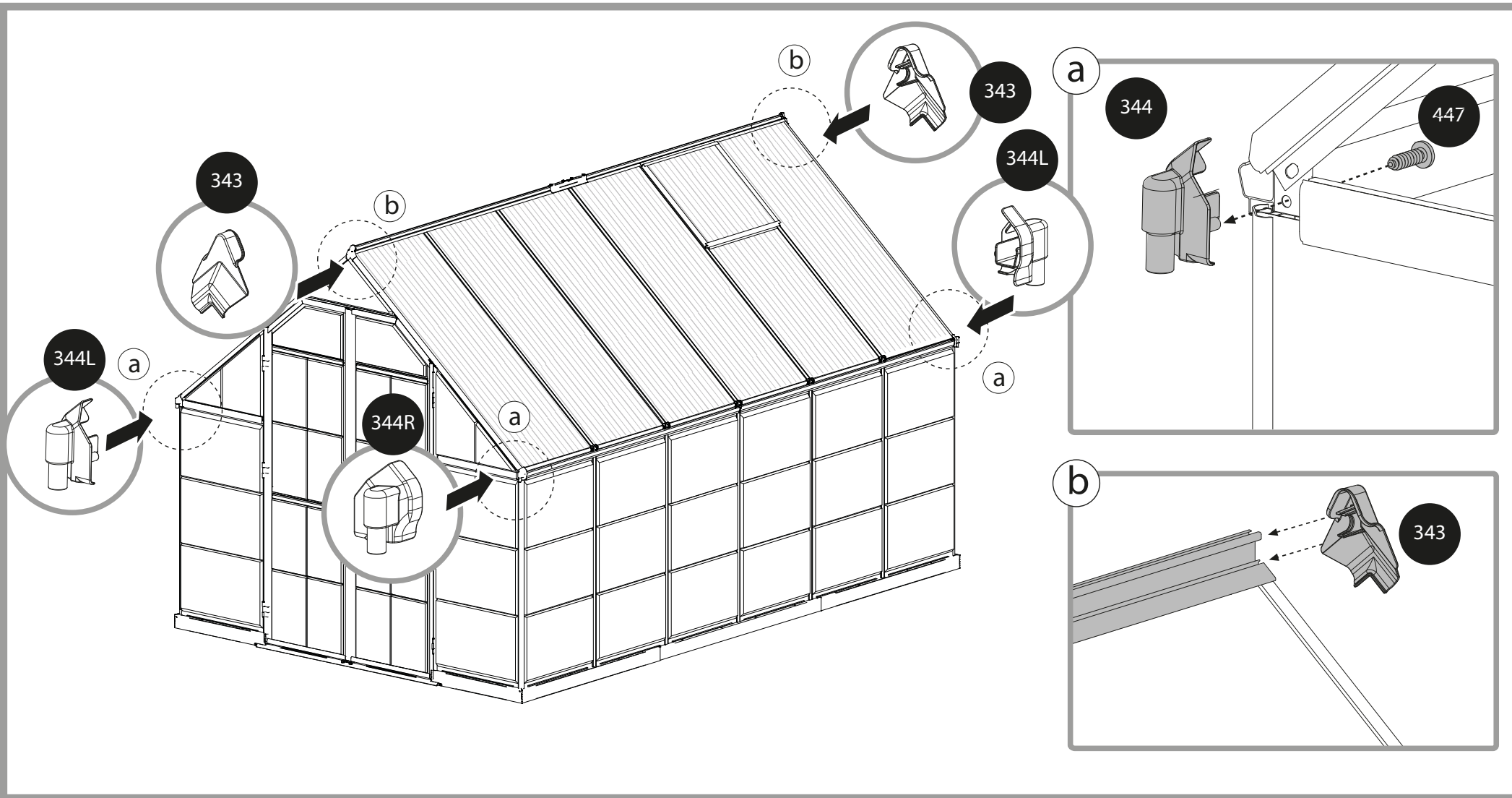
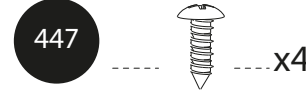
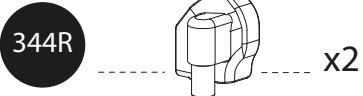
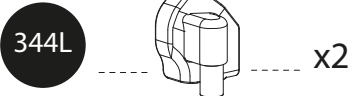
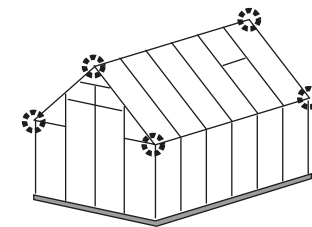

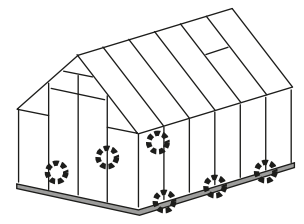

926

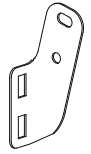

x6

461



x12

412



x24

411

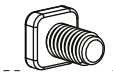

x12

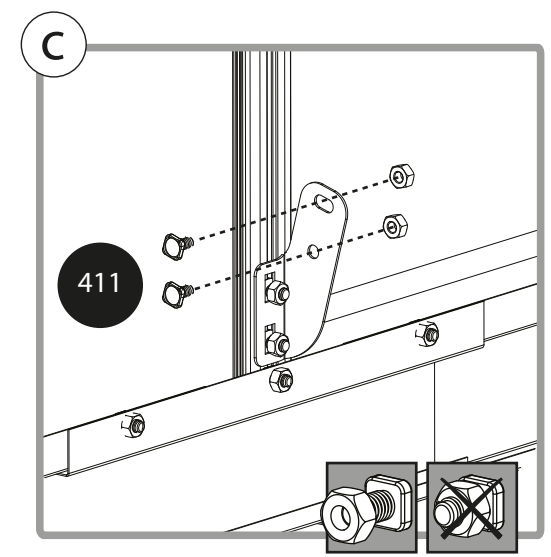
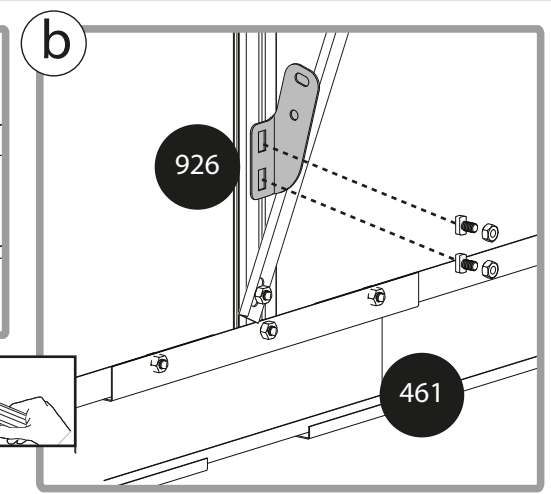
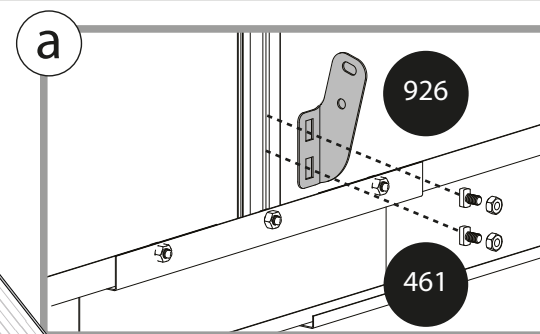
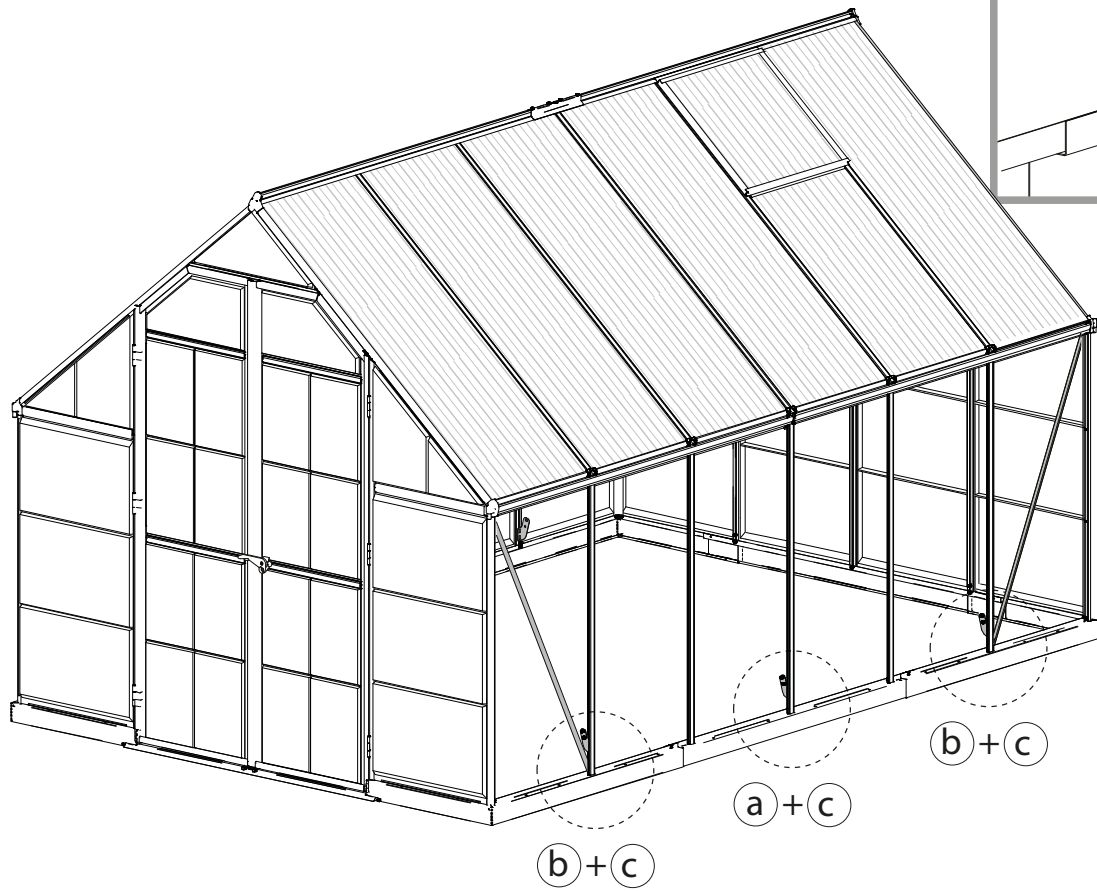

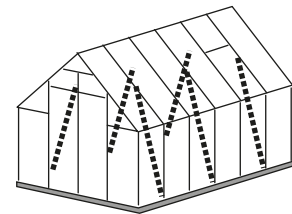

966

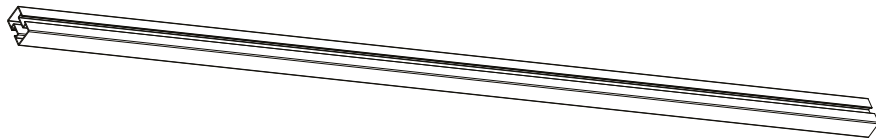
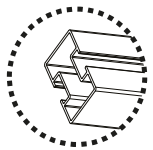

x6

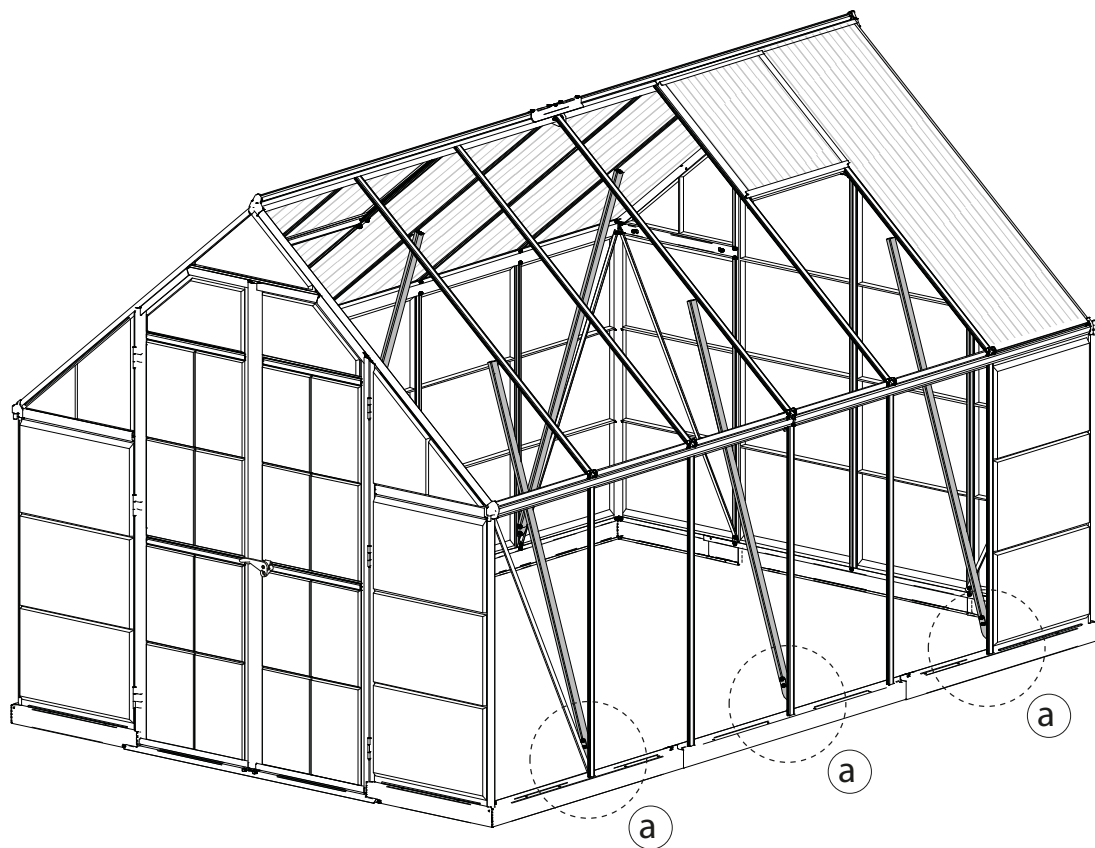

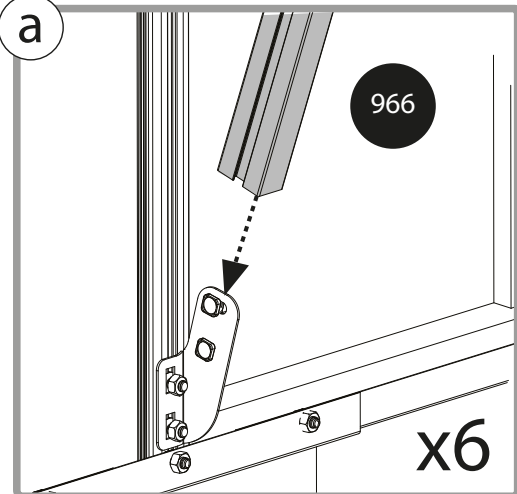

a

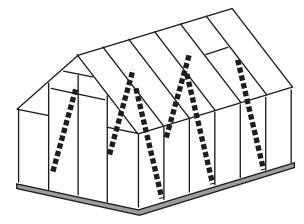

966

x6

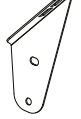

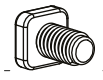
- 456  x6
- 461  x12
- 412  x24
- 411  x12

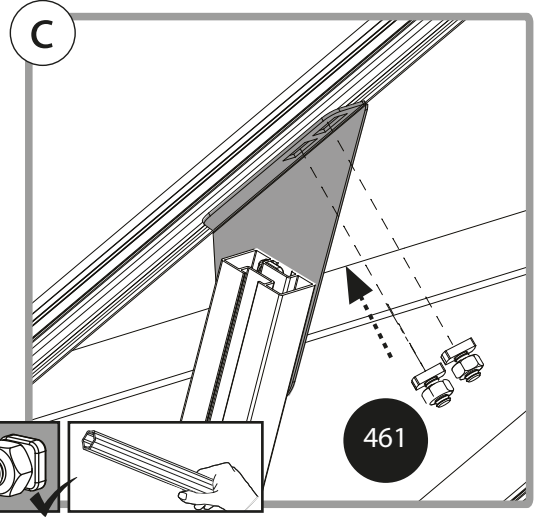
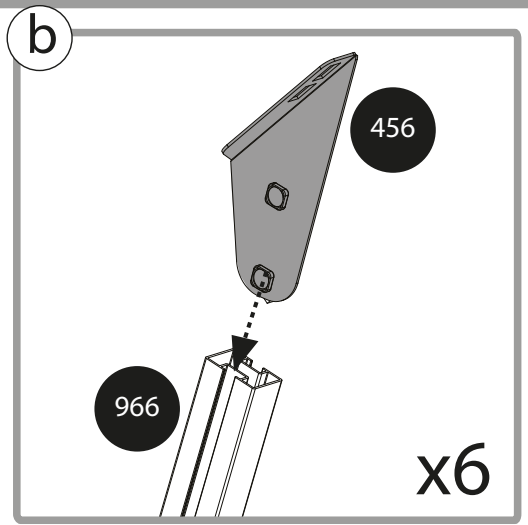
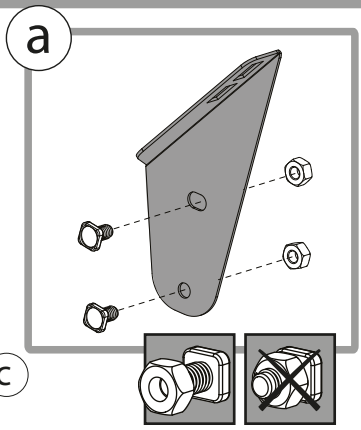
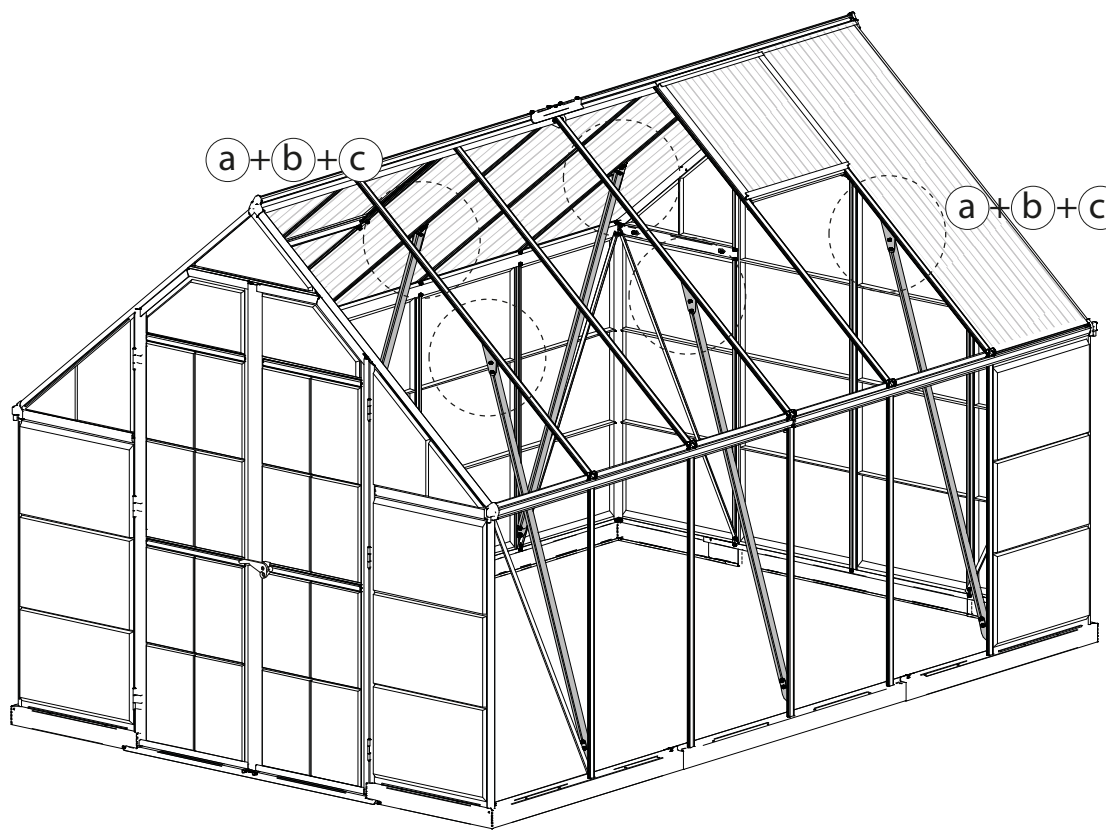

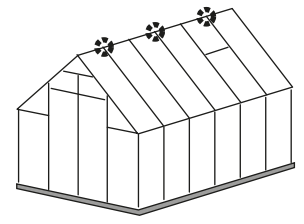

459

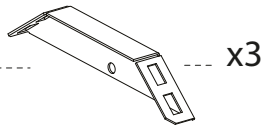

461

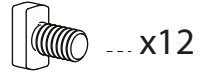

412

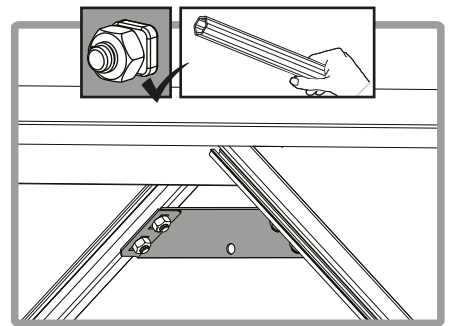
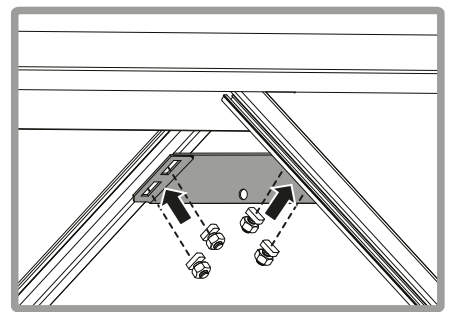
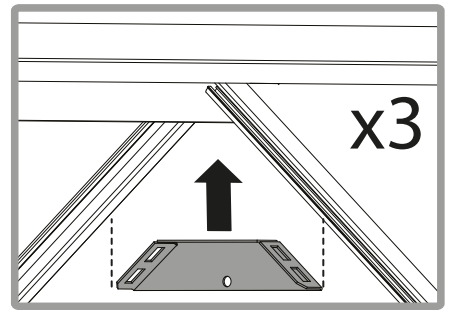
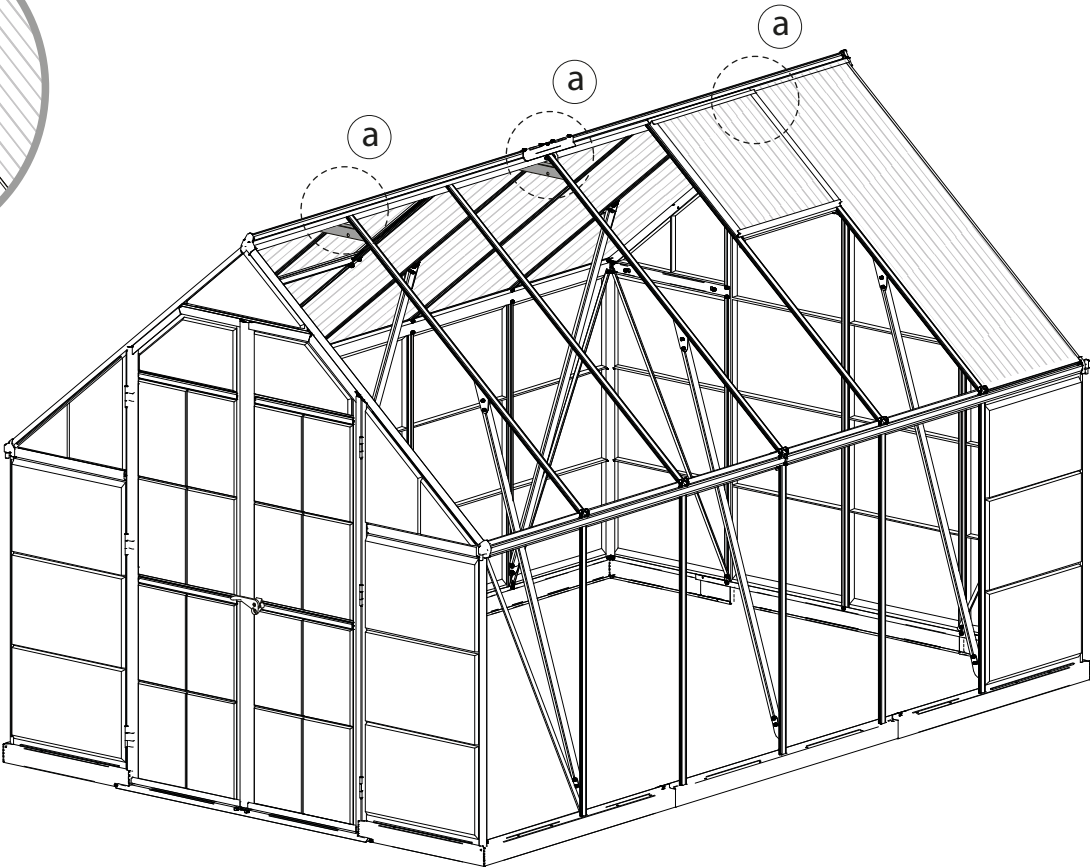
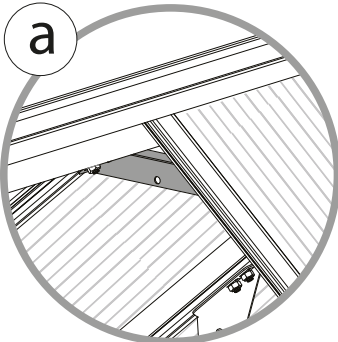

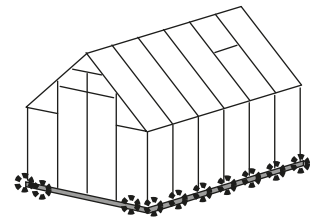

M96

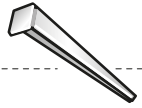

x6

P328

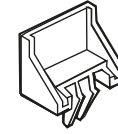

x36

