

no.	name	quantity	no.	name	quantity
1	water fender	1	32	Liquid level switch	1
2	St46 screw	1	33	Reverse wind function button	1
3	Blow molding bent pipe	1	34	Reverse wind function spring	1
4	Connecting column	1	35	Rear cover handle	1
5	Floating ball holder	1	36	Rear cover	1
6	Floating ball	1	37	Cardboard spring	1
7	St46/0 screw	1	38	Cardboard fixed axle	1
8	Plate filter	1	39	Pressing line plate	1
9	Plate filter holder	1	40	Rear cover sealing ring	1
10	Safety valve	1	41	Circuit board	1
11	Bottom cover sealing ring	1	42	Motor upper cover	1
12	Bottom cover	1	43	Power cord stopper	1
13	Motor upper sealing ring	1	44	Middle cover sealing ring	1
14	Motor A30-1	1	45	Inner barrel	1
15	Motor down sealing ring	1	46	Inner barrel sealing ring	1
16	Middle cover	1	47	Connecting column sealing ring	1
17	Air outlet flapper	1	48	Push rod holder	1
18	Air outlet base	1	49	Push rod	1
19	Air outlet base spring	1	50	Power cord 3*1.5mm <sup>2</sup> , 4.5m	1
20	Air outlet base fixed axle	1	51	Small 7" brush φ32	1
21	Front cover	1	52	Small nozzle φ32	1
22	Synchronizer	1	53	Metal telescopic tube	1
23	Reverse wind function board sealing ring	1	54	Dusting	1
24	Reverse wind function board	1	55	Rose assemblies φ32, 2m	1
25	Air duct cover	1	56	Manual	1
26	Switch(3P)	1	57	MetalDry brush φ32	1
27	Speed controller	1			
28	Handle	1			
29	Top cover	1			
30	Air tools joint	2			
31	air valve seat	1			

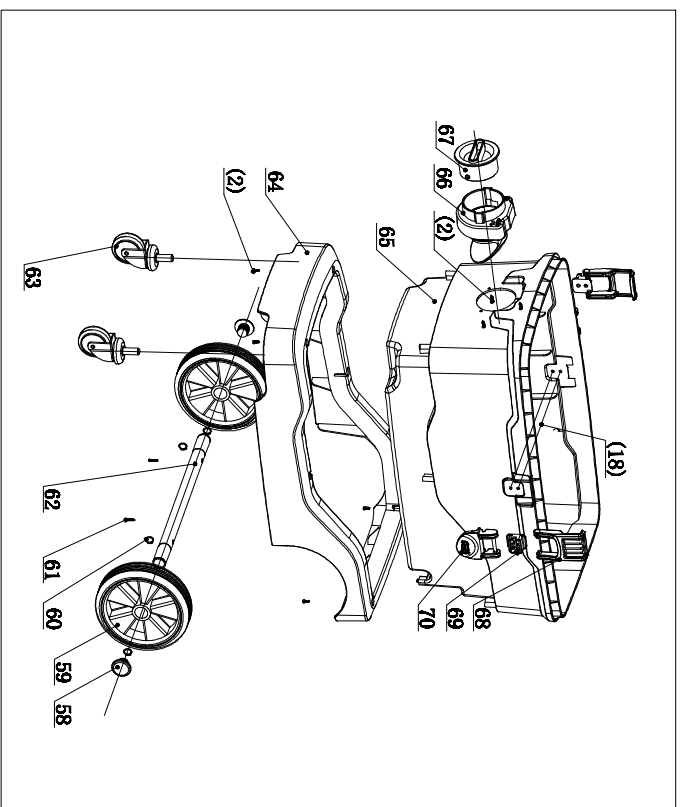

no.	name	quantity	no.	name	quantity
58	Steel pipe stopper	2	65	Outer barrel	1
59	Rear wheel	2	66	Air inlet base	1
60	φ19 jump ring	2	67	Air inlet cover	1
61	St46/0 screw	1	68	Plastic hasp	2
62	Rear wheel rod	1	69	Plastic hasp base	2
63	φ50 metal front wheel	2	70	Plastic hasp joint	2
64	Bottom base	1	71		