

Item: 1815016L
Capacity: 1.5 TON

EU Declaration of Conformity (Translation of the original EU Declaration of Conformity)

We
Changshu Tongrun Auto Accessory Co., Ltd
New Longfeng Industrial Park
Changshu Economic Development Zone
215500 Changshu City, Jiangsu Prov,
PEOPLES REPUBLIC OF CHINA
Tel: +86-512-52343388
wangjif@longrunjacks.com

Declare under our sole responsibility that the follow product

Equipment: Floor jack
Brand name: Big Red
Model/type: T815016L

**Is in conformity with the Machinery Directive (MD) 2006/42/EC
And the following harmonized standards and technical specifications have been applied:
MD: EN 1494: 20000+A1:2008**

Changshu 30.03.2018
Manufacturer: Changshu Tongrun Auto Accessory Co., Ltd

Wang Jingfang

Jingfang Wang, Engineer (authorized to compile the Technical File)

1.5 TON ALUMINIUM/STEEL FLOOR JACK

- FR CRIC EN ALUMINIUM/ACIER
- ES GATO DE ALUMINIO/ACERO
- DE WAGENHEBER AUS ALUMINIUM/STAHL
- RU ДОМКРАТ АЛЮМИНИЕВЫЙ/СТАЛЬНОЙ

OWNER'S MANUAL



Manual & trouble shooting
QR code

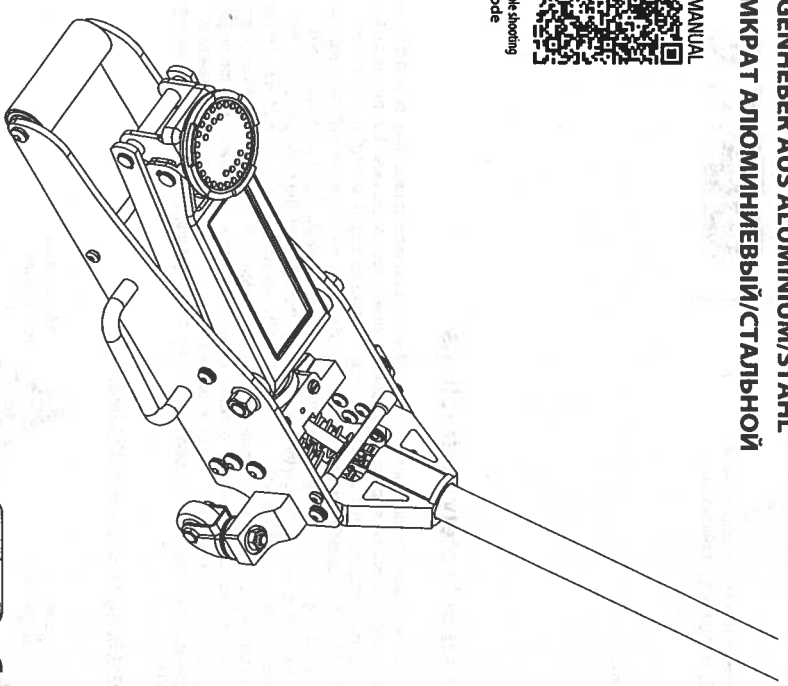

Please read these instructions carefully before using the product for the first time and store them for future reference. This product must be operated in accordance with these instructions at all times. Make these instructions for use accessible to all persons who will be working with this product. This applies also when reselling the product. We cannot assume any liability for any accidents or damage that may arise due to non-observance of this guide or the safety instructions contained therein. Any structural modifications to the product will void the manufacturer's warranty!

This product is intended for private use only!

Technical specifications

Description: Aluminum/Steel Floor Jack
Model: T815016L
Nominal load: max. 1.5 tonnes
Lifting height: min. 88 mm to max. 358 mm
Total length: ca. 554 mm
Own weight: ca. 14.3 kg
Lifting height with rated load(mm):210-358
Design conforms to the EN1494/A1:2008

This floor jack has been TÜV/GS tested and bears the CE sign.



Made in China

Intended use / safety instructions

This product is a floor jack for lifting motor vehicles. It is intended for use as a lifting device only. Ensure that the load to be lifted does not exceed the maximum permissible load of the jack. The maximum load of 2 tonnes must not be exceeded otherwise the jack may become damaged and safety compromised. Use the jack on a firm, even surface only. Instability or slipping of the load may occur on soft or uneven surfaces. Consequential damage to the vehicle or persons cannot then be precluded. (Risk of accident!). Make sure there are no persons inside the vehicle being lifted. Position the hydraulic jack so that no part of your body will be under the vehicle while it is being lifted. Never work under a car that is being supported only by the hydraulic jack. Always use additional supports. Before lowering the hydraulic jack, ensure there are no persons or objects under the vehicle. Never leave the hydraulic jack unattended for longer periods when it is supporting a load as it can lose pressure and begin to sink for design-related reasons. Therefore place something underneath the lifted load immediately! Never get into the vehicle or start its engine while it is on the hydraulic jack.

WARNING: Lifting of persons prohibited!



General warning sign



Warning about hand injuries

REF#	PART#	DESCRIPTION	QTY
1	T815016L-GS-1	Power unit assembly	1
2		Universal joint assembly	1
3		Steel ball Ø6mm	1
4		Oil plug	1
5		Coiler pin Ø4x45mm	1
6		Coupling connector	1
7		Handle socket screw M8X19,5mm	1
8	T815016L-2	Handle socket	1
9		C-clip Ø8mm	1
10		Roller	1
11		Pin for roller	1
12	T815016L-3	Supporting axle	1
13	T815016L-1	Handle assembly	1
14		Foam protective pad	1
15		Piece of spring	1
16		Button-head socket cap screw M8X16mm	10
17		Caster base	2
18	T815012L-8(asm)	Rear caster assembly M10	2
19	T815016L-5	Saddle pad	1
20	T815016L-12	Saddle pin	1
21	T815016L-11	Saddle	1
22	T815016L-6	Front wheel shaft	1
23	T815016L-8	Shaft for connected bar	1
24	T815016L-10	Saddle base	1
25	T815016L-6	Front wheel assembly	1
26	T815012L-15	Sleeve for connected bar shaft	2
27	T815016L-7	Lifting arm assembly	1
28	T815016L-9	Shaft for saddle base	1
29	GB8894-1-14	C-clip Ø14mm	2
30	T815016L-7	Connected bar	2
31	GB8984-1-Ø13	C-clip Ø13mm	2
32	GB/T 70-3-M8X20	Flat-head socket cap screw M8X20mm	2
33		Slide plate	2
34	GB/T 70-2-M8X20	Button-head socket cap screw M8X20mm	2
35		Washer M6	4
36		Button-head socket cap screw M6X16mm	4
37	T815016L-4-2	Carry handle	1
38		Washer M8	4
39		Spring washer M8	6
40	GB/T 97-1	Washer M14	2
41	GB/T 898-1	Nut M14	2
42	GB/T 899	Washer M10	6
43	GB/T 70-2	Button-head socket cap screw M10X20mm	6
44	T815016L-1	Handle socket shaft	2
45		Return spring	2
46	GB/T 894-1	C-clip Ø19mm	2
47	T815012L-4	Rubber sleeve	2
48	T815016L-2	Position shaft	2
49	T815016L-4	Connected bar pin/le	2
50	T815016L-13	Shaft	1
51	T815016L-MF	Seal kit	1

General usage instructions

Before using the floor jack, check for loss of oil, damage or missing accessories.

First time operation:

1. Open the drain valve (1) and insert the enclosed handle (extension) in the pumping arm (2). To ensure the oil distributes itself completely, carry out approx. 6 full pumps of the handle.
2. Close the drain valve - the vehicle jack is now ready for use.

Lifting the vehicle:

3. Locate your vehicle on an even, firm surface and secure the vehicle against rolling as specified by the vehicle manufacturer.
4. To ensure safe lifting, position the jack at a 90° angle to the vehicle and under the appropriate jacking point (see the manufacturer's instructions).
5. Insert the handle in the drain valve and close it by rotating clockwise until the limit stop is reached. Insert the handle in the pumping arm and pump the handle until the saddle (3) is in contact with the vehicle.
6. Check again that the jack is seated correctly.
7. Continue pumping the handle until the vehicle has been lifted to the desired height.
8. **Caution:** Observe the vehicle carefully during the lifting operation. The jack should move in the direction of the vehicle during lifting. Should this not be the case, there is a strong possibility that the vehicle will slide off the jack.
9. Put the handle out of the pumping arm. (Risk of accident!)
10. Secure the load with suitable jack stands before commencing work on or under the vehicle. **Caution:** Working on or under the vehicle without first appropriately securing the raised load is prohibited! (Risk of accident!)
11. After you have finished working on the vehicle, open the drain valve by carefully twisting the jack handle in small increments in a counterclockwise direction until the vehicle begins to move downwards.
12. Once the vehicle is firmly on the ground, the drain valve can be opened again (approx. one half turn) in order to return the lifting arm (4) all the way to the bottom in the starting position.
13. Before lifting the load, check that the drain valve is properly closed.
14. All moving parts must be lubricated in accordance with the operators' manual and maintained on a regular basis.

Storage & care:

15. When the vehicle jack is not in use, the lifting arm should be in the lowest position and the handle in an upright position to protect the precision mechanics from damage. The vehicle jack must be stored in a horizontal position and in a dry location. Ensure the jack remains in its original condition. Do not undertake any modifications to the device.
16. Use only SAE10 (SAE: Society of Automotive Engineers) grade, special-purpose hydraulic oil for the pump. Dispose of all used and spilled oil appropriately.
17. Do not use a high pressure cleaner to clean the jack. All external moving parts, e.g. the foot roller bearings (5), fastening bolts of the lifting arm (6), fastening bolts of the lifting arm cylinder (7) and fastening bolts of the pumping arm (8) must be well lubricated regularly every 3 months. **IMPORTANT:** Never lubricate or grease the rods of the pump (9) and lifting cylinder (10).
18. All maintenance and repair work must be performed by a suitably qualified personnel in accordance with the manufacturer's instructions.
19. **Caution:** Do not use the jack if there are any missing, loose or broken parts!



NOTE: The instructions below must not be carried out while the vehicle jack is in use.

NOTE: The vehicle jack is equipped with a safety valve (15). It has been configured to allow the vehicle jack to lift loads up to 2 tonnes. The safety valve must not be modified or adjusted in any way!

Troubleshooting

Problem 1: The lifting arm won't raise when pumping under load.

- Check whether the drain valve is fully closed. Close it by rotating the handle clockwise.
- Check the oil level by placing the vehicle jack in a horizontal position.
- Not enough oil. Top up the hydraulic oil and purge the hydraulic system - see also the "Topping up the hydraulic oil" and "Purging" sections.

Problem 2: The lifting arm is sinking under load.

- Follow the instructions provided for "Problem 1". Should this still not eliminate the fault, the vehicle jack needs to be repaired by an authorized repairer.

Problem 3: The lifting arm can't be lowered.

- The tension spring for the lifting arm has unhooked or broken. Rehook the spring or replace the broken spring by an equivalent new spring.
- The vehicle jack presumably needs lubricating. All moving parts must be cleaned and lubricated or greased. (see "Instructions for use"; item 17). **IMPORTANT:** The rods of the pumping and lifting cylinder should never be lubricated or greased.
- Too much oil in the hydraulic system. Screw out the drain valve and drain out the excess oil - see also the "Topping up the hydraulic oil" and "Purging" sections.

