











# ASSEMBLY INSTRUCTION SHEET

PARTS LIST							
①	UPPER COVER		1	A	PLASTIC BOLT CAP		30
②	FRONT PANEL		1	B	METAL WASHER		28
③	BACK PANEL		1	C	BOLT (M6x25mm)		4
④	LEFT PANEL		1	D	BOLT (M6x40mm)		24
⑤	RIGHT PANEL		1	F	PE WASHER		4
⑥	BOTTOM PANEL		1	G	ALLEN WRENCH		2
⑦	STORAGE BAGS		1				

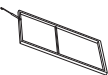
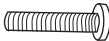
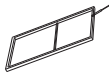

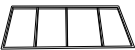
# STEP 1

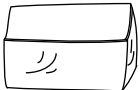
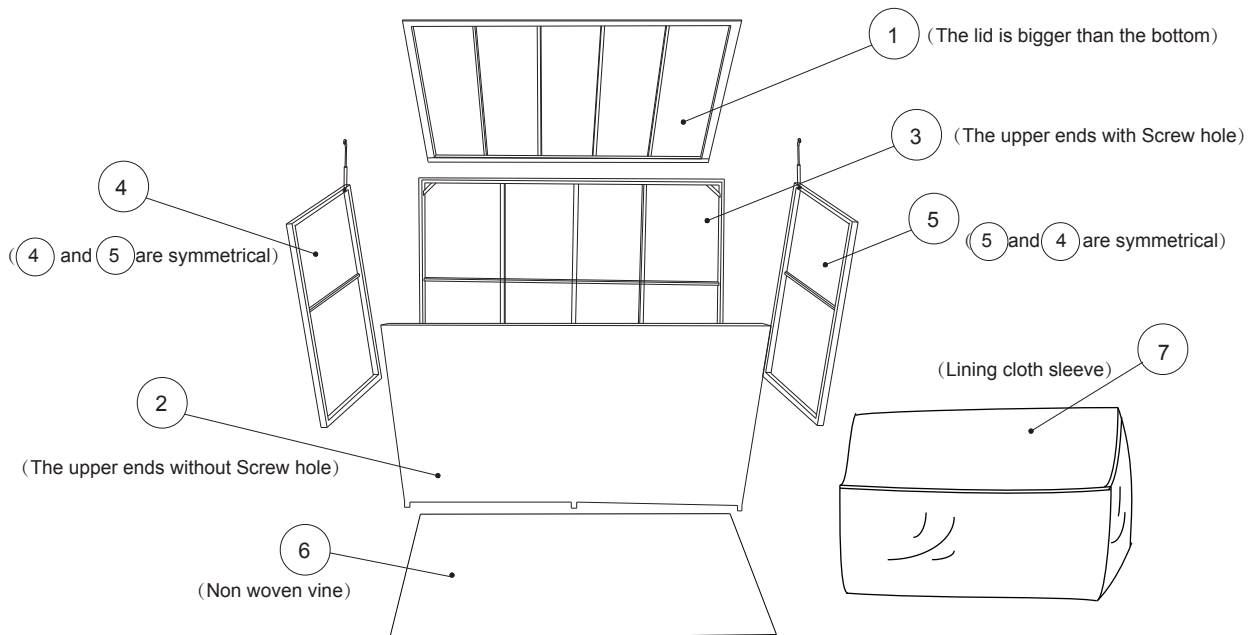
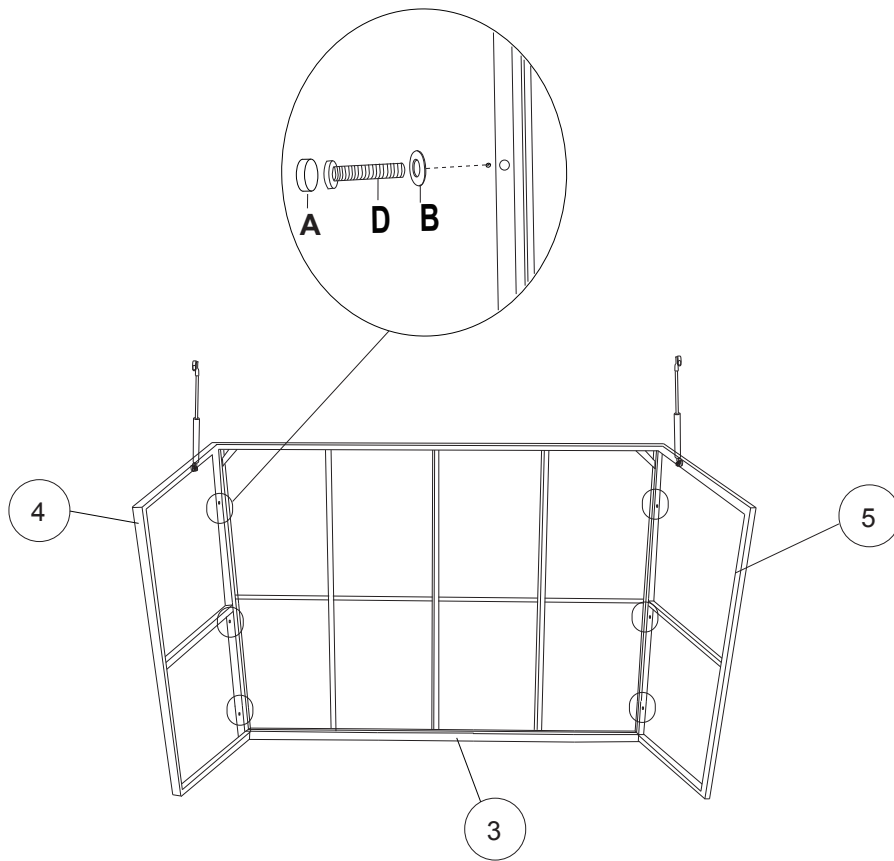

# STEP 2

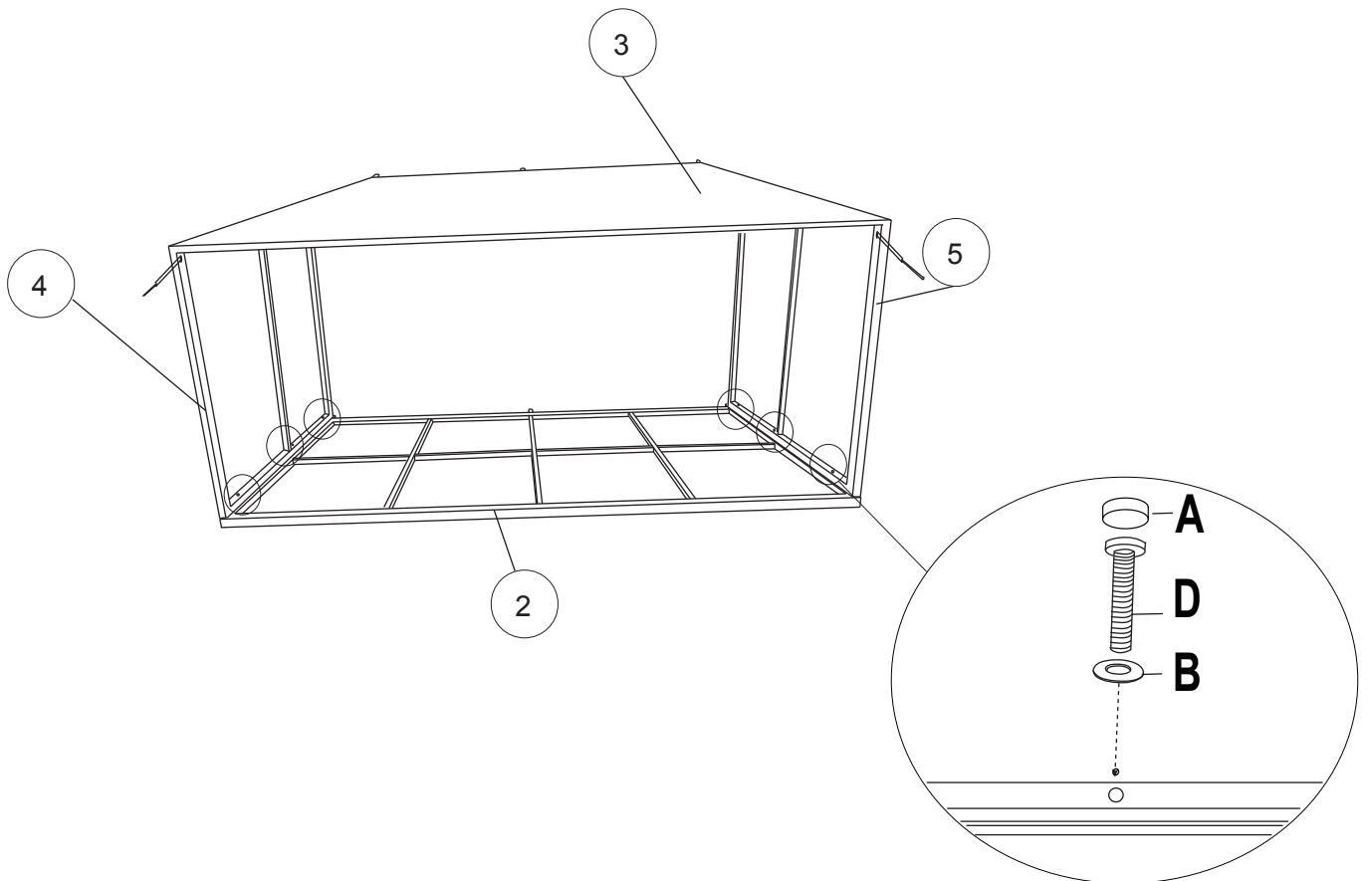

## STEP 3

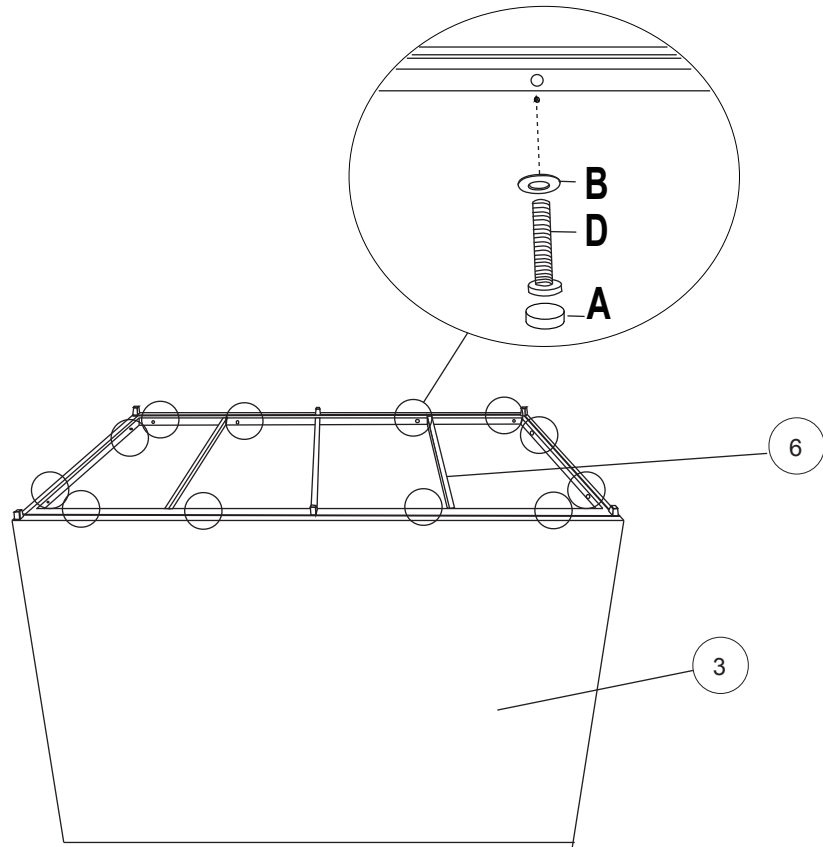

- Remember to fully tighten all bolts before turning over.

## STEP 4

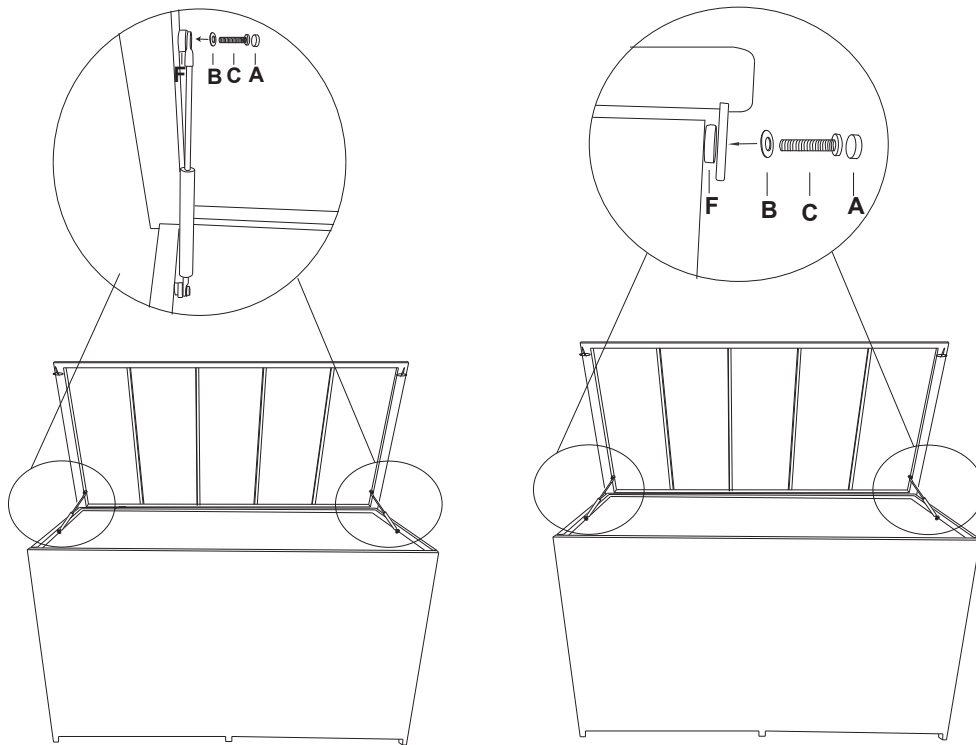

- Remember to fully tighten all bolts before turning over.